



This is a digital copy of a book that was preserved for generations on library shelves before it was carefully scanned by Google as part of a project to make the world's books discoverable online.

It has survived long enough for the copyright to expire and the book to enter the public domain. A public domain book is one that was never subject to copyright or whose legal copyright term has expired. Whether a book is in the public domain may vary country to country. Public domain books are our gateways to the past, representing a wealth of history, culture and knowledge that's often difficult to discover.

Marks, notations and other marginalia present in the original volume will appear in this file - a reminder of this book's long journey from the publisher to a library and finally to you.

Usage guidelines

Google is proud to partner with libraries to digitize public domain materials and make them widely accessible. Public domain books belong to the public and we are merely their custodians. Nevertheless, this work is expensive, so in order to keep providing this resource, we have taken steps to prevent abuse by commercial parties, including placing technical restrictions on automated querying.

We also ask that you:

- + *Make non-commercial use of the files* We designed Google Book Search for use by individuals, and we request that you use these files for personal, non-commercial purposes.
- + *Refrain from automated querying* Do not send automated queries of any sort to Google's system: If you are conducting research on machine translation, optical character recognition or other areas where access to a large amount of text is helpful, please contact us. We encourage the use of public domain materials for these purposes and may be able to help.
- + *Maintain attribution* The Google "watermark" you see on each file is essential for informing people about this project and helping them find additional materials through Google Book Search. Please do not remove it.
- + *Keep it legal* Whatever your use, remember that you are responsible for ensuring that what you are doing is legal. Do not assume that just because we believe a book is in the public domain for users in the United States, that the work is also in the public domain for users in other countries. Whether a book is still in copyright varies from country to country, and we can't offer guidance on whether any specific use of any specific book is allowed. Please do not assume that a book's appearance in Google Book Search means it can be used in any manner anywhere in the world. Copyright infringement liability can be quite severe.

About Google Book Search

Google's mission is to organize the world's information and to make it universally accessible and useful. Google Book Search helps readers discover the world's books while helping authors and publishers reach new audiences. You can search through the full text of this book on the web at <http://books.google.com/>

UC-NRLF



#B 74 242

MANUAL No. 3

ELECTRICAL INSTRUMENTS AND TELEPHONES

OF THE

U. S. SIGNAL CORPS

REVISED

1910

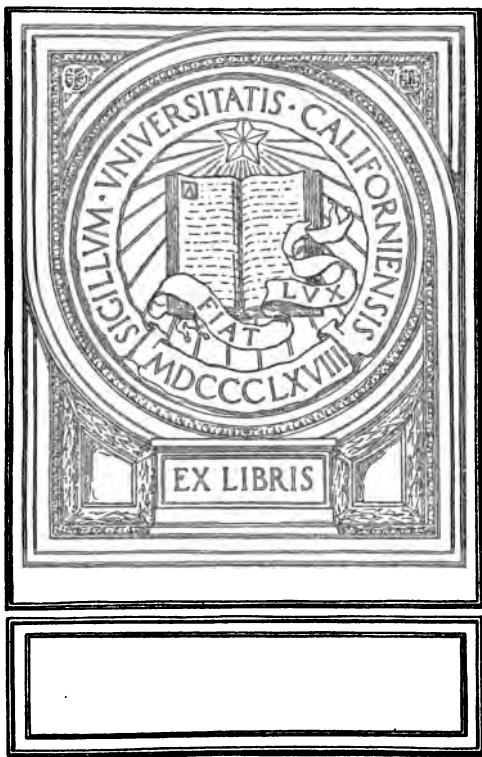

12813

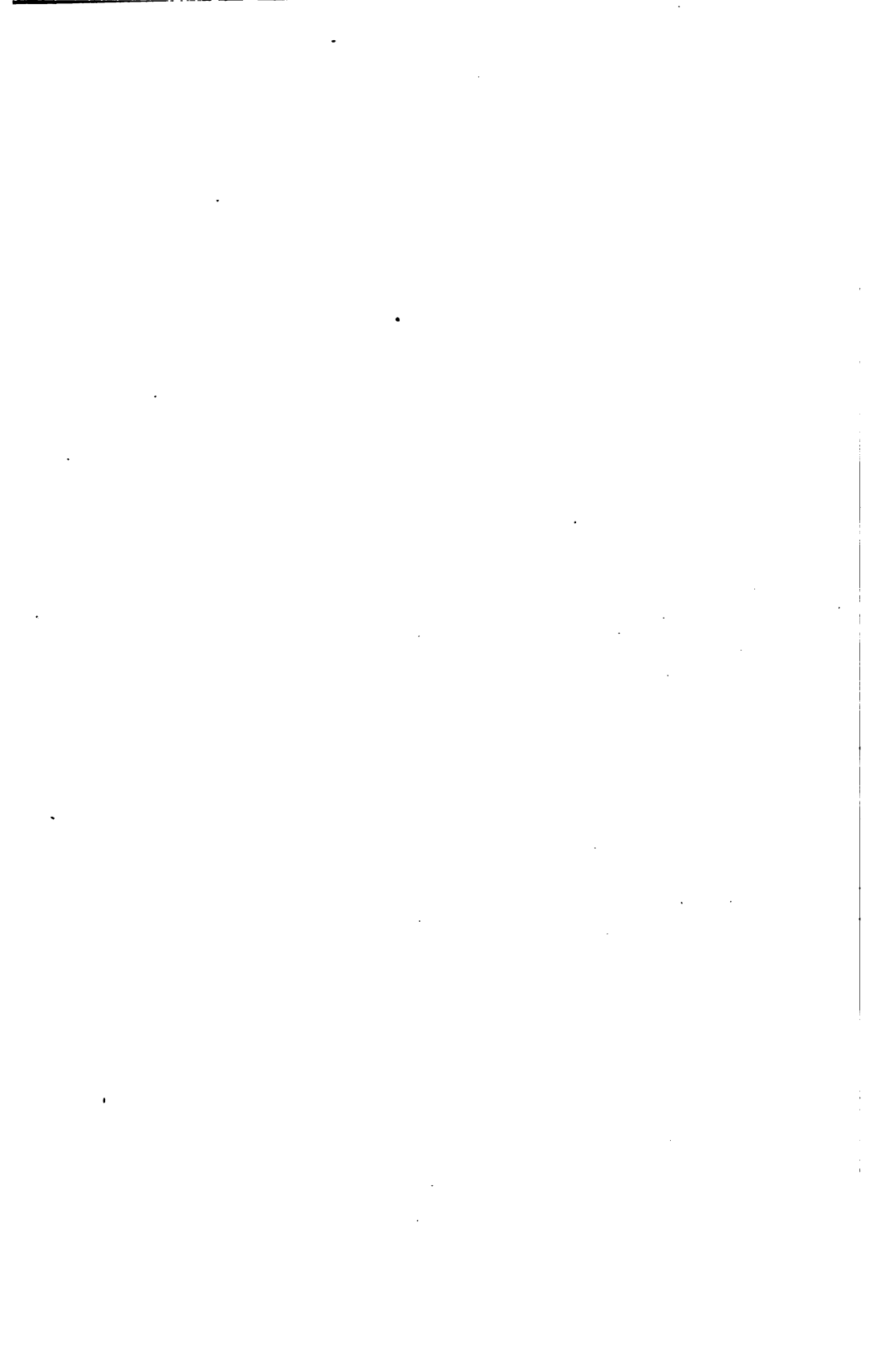

MANUAL No. 3

ELECTRICAL INSTRUMENTS
AND TELEPHONES

OF THE

U. S. SIGNAL CORPS

REVISED 1910



UNIV. OF
CALIFORNIA

WASHINGTON
GOVERNMENT PRINTING OFFICE
1911

UG, 570

UG
1710

WAR DEPARTMENT.

DOCUMENT NO. 378.

OFFICE OF THE CHIEF SIGNAL OFFICER OF THE ARMY.

2

TO MRU
ABSTRACTS

WAR DEPARTMENT,
OFFICE OF THE CHIEF OF STAFF,
Washington, September 19, 1910.

The following Manual of Electrical Instruments and Telephones, prepared in the office of the Chief Signal Officer, is approved, and published for the information and guidance of the Regular Army and the Organized Militia of the United States.

The instructions contained in this manual for the installation, operation, and maintenance of the electrical equipment of the Signal Corps, other than fire-control equipment, will replace all others heretofore issued upon the subject. Officers and men of the Signal Corps will thoroughly familiarize themselves with the general information contained herein.

By order of the Acting Secretary of War:

LEONARD WOOD,
Major-General, Chief of Staff.

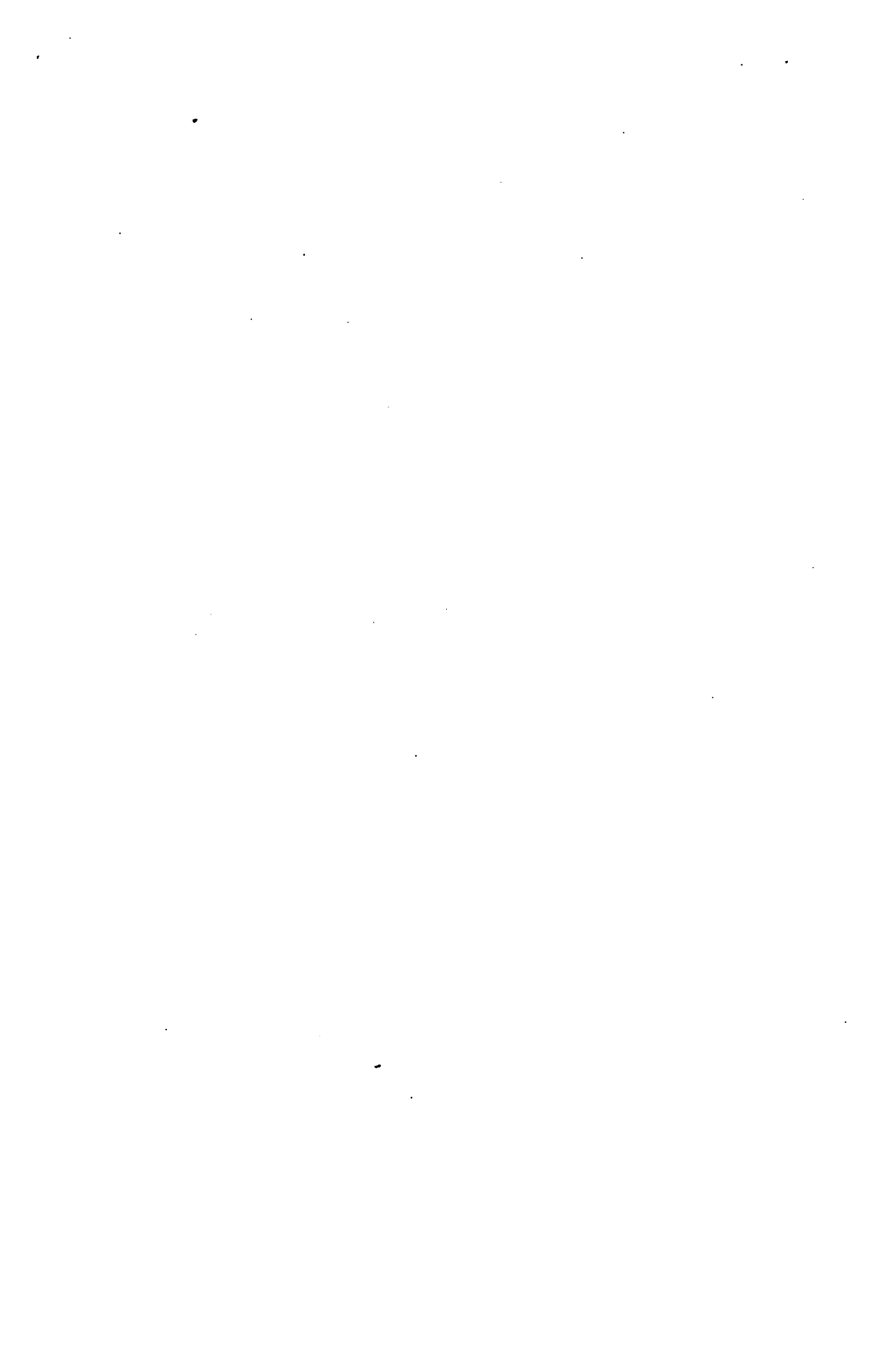

TABLE OF CONTENTS.

	Page.
Introduction	7
CHAPTER I.	
Definitions, units, and formulæ:	
Current, voltage, resistance, etc.....	9
CHAPTER II.	
Batteries and battery equipment:	
Primary cells, types, construction, uses for each, maintenance, open and closed circuits.....	16
Secondary cells, principles, installation, operation, uses for.....	27
CHAPTER III.	
The Morse telegraph:	
Circuits, equipment, installation, office equipment, operation, and adjustment	60
Repeaters—systems, operation, and adjustment	69
Duplex and quadruplex systems, operation and adjustment	73
CHAPTER IV.	
Buzzers:	
Theory, types, uses of each, circuits	101
CHAPTER V.	
Telephones:	
Theory, field telephones, field-artillery-type telephones, circuits of each and uses, troubles, and repairs	112
CHAPTER VI.	
Telephone switchboards and exchange equipment:	
Types, circuits, installation, troubles, protectors.....	145
CHAPTER VII.	
Line construction:	
Open wire, aerial cable, underground cable	183
CHAPTER VIII.	
Testing and testing apparatus.....	242
CHAPTER IX.	
Field lines of information and field equipment.....	283
CHAPTER X.	
Miscellaneous tables and information	300



INTRODUCTION.

Since the issue of the 1905 edition of this manual considerable progress has been made in perfecting signal-corps equipment, resulting in developing new types of apparatus and modifying former standard types. As the supply of the last edition is almost exhausted, it is considered desirable to take advantage of the opportunity to revise and extend the text to conform to the conditions which obtain at the present time.

In view of the rapidly increasing application of electricity to warfare, the importance of a thorough knowledge of the electrical instruments and equipment can not well be overestimated.

As regards telephones, there should be not only a thorough familiarity with the ordinary methods of operating telephone lines, whether the instruments are bridged or in series, but also a knowledge of the construction of the various types of telephones herein described, so that faults may be readily located and remedied.

Not only should officers and men be able to install and operate all instruments and equipment described in this manual, but they should also be familiar with so much of the theory of electricity as bears directly or indirectly on their work.

It is intended in issuing the manual to provide in convenient form in simple nontechnical language the information as to signal-corps equipment necessary to accomplish the ends outlined above. In compiling the subject-matter of this manual free use has been made of current data from various sources.

Part of the chapter on "Repeaters" and all of the chapter on "Duplex methods" are taken, by courtesy of the author, Mr. William Maver, jr., from that excellent work, American Telegraphy.

A republication of some of the valuable articles of Mr. Willis H. Jones, originally published in the Telegraph Age, on adjusting office instruments will be useful to operators.

An interesting extract from the Western Union publication on "Construction of permanent lines" is inserted by the permission of Col. R. C. Clowry, the president of the Western Union Telegraph Company.

Much valuable information as to construction methods and apparatus and electrical data has been obtained from the trade publica-

tions of the following: Standard Underground Cable Company, Western Electric Company, W. N. Mathews & Bro., and the Electric Storage Battery Company.

Much of the data contained in the last chapter was taken from Foster's Electrical Engineer's Pocket Book, through the courtesy of Mr. Horatio A. Foster, the author, and the D. Van Nostrand Company, of New York, publishers.

The chapters on telephones describe the construction and operation of the various types of telephones and switchboards supplied by the Signal Corps for the use of the Army; consequently no reference to the engineering principles involved is made.

Much of the apparatus described has been designed by the Signal Corps to meet the special necessities of military service, where the requirements are quite different from those of commercial life. In the field apparatus strength and portability are the predominating features of design, while the efficiency of talking and ringing circuits is maintained.

CHAPTER I.

PRINCIPLES OF MAGNETISM AND ELECTRICITY.

MAGNETISM.

A bar of steel or iron which has the properties of attracting other pieces of steel or iron is called a magnet. When freely suspended at its center it will point north and south. It can also impart these powers to another piece of iron or steel without losing any of its own.

The ends of a magnet are called its poles. The end which points toward the north is its north pole and the other end its south pole. The north end of any magnet will repel the north ends of all other magnets, but will attract all south poles. From this follows the law of magnetic attraction, "like poles repel and unlike poles attract."

The force exerted by one magnet on another to attract or repel it is called magnetic force. If iron filings be spread on a paper laid over a bar magnet, the filings will arrange themselves about the magnet in curves which end at the poles. These curves are called lines of force, and the whole space occupied by the curves is the magnetic field of force, or magnetic field. It is assumed that the lines of force come out from the north pole of the magnet, pass through the air, reenter the magnet at the south pole and pass through it to the north pole, thus completing the path. This path forms the magnetic circuit, and each of the lines of force completes it without crossing or combining with any one of the others in the field. A line of force always forms a closed loop, so that as many lines enter the south pole as leave the north.

To make a magnet of a steel bar, place the bar flat on a table. Take the south pole of a magnet and stroke the bar with it several times, always from end to end in the same direction. The end of the bar first touched will then become a south pole and the end where magnet last touched a north pole. The bar will then be a magnet. Or wind a few turns of insulated wire around the bar and pass a current of electricity through the wire for a short time, gently tapping the bar with a hammer while the current is flowing. Upon removing the bar from the coil it will be found to be a magnet.

If a piece of iron, mounted on a pivot so it is free to swing about, be placed in a magnetic field of force, the iron will move so that the greatest number of lines of force of the field will pass through it.

If the movable body be a magnet, for example, a compass, it will turn, under the influence of the field, so that not only the greatest number of lines of force will pass through it, but also so that its own lines of force will be in the same direction as those of the field. Upon this fact is based the construction of many forms of electrical instruments.

If a bar of soft iron be placed in the field of a bar magnet, we will find on testing the soft iron bar that it, too, has become a magnet having two distinct poles. The iron bar is called the body under induction, the magnet the inducing body, and this phenomenon magnetic induction. Magnetic induction is defined as the action and reaction which occur when a magnetic field makes a magnet of a body placed therein.

Two dissimilar metals as copper and zinc connected by a wire and immersed in a weak sulphuric acid solution which acts upon one more than the other constitute a voltaic cell. The metals are the plates; the solution is the electrolyte. The term circuit is applied to the entire path through which the current of electricity flows. The wire joining the plates is the conductor. That part of the circuit outside of the cell is the external circuit; that on the inside, the internal circuit. Bringing the two ends of the conductor into contact is called making or closing the circuit, and their separation opening or breaking the circuit. A substance through which the current flows readily is a good conductor. Any substance through which the current will not flow is an insulator. Most metals are good conductors, while mica, glass, dry wood, rubber, etc., are good insulators.

The copper plate in the above experiment is the negative plate; the wire attached to it the positive pole. The zinc plate is the positive plate or element, and its wire or terminal the negative pole. It has been agreed that the current flows from the positive to the negative plate through the internal circuit and from the positive to the negative pole through the external circuit. Therefore, in any source of electric current, that pole from which the current flows is considered positive, and that pole to which the current flows, negative. The combination of elements, acid, and containing vessel constitutes a voltaic cell.

OHM'S LAW.

In any circuit through which a current is flowing there are three factors: (1) The difference of potential between the plates, known as the pressure or electromotive force, the unit of which is the volt; (2) the resistance, or opposition, by the conductor to the flow of current expressed in ohms; (3) the current strength, expressed in amperes. A current exists in the circuit by reason of the pressure over-

coming the resistance. A definite relation exists between these factors so that the value of any one of them can be found if the values of the other two are known. This relation, expressed by Ohm's law, is as follows:

(a) The current strength in a circuit may be found by dividing the pressure, or electromotive force, applied to it, by the resistance.

$$C \text{ (in amperes)} = \frac{E \text{ M F (in volts)}}{R \text{ (in ohms)}}.$$

(b) The electromotive force, or pressure, required to maintain a certain current strength in a circuit may be found by multiplying the current in amperes by the resistance in ohms.

(c) The resistance in any circuit may be found by dividing the electromotive force by the current strength.

$$R \text{ (in ohms)} = \frac{E \text{ M F (in volts)}}{C \text{ (in amperes)}}.$$

When the total electromotive force is used in Ohm's law, the total resistance must be used to calculate the current strength. For example, if a coil of 0.5 ohm resistance is connected to a cell of 2 volts

$E \text{ M F}$, the current through the coil would not be $\frac{E}{R}$ or $\frac{2}{0.5} = 4$ am-

peres as might be supposed. It requires a certain part of the cell's $E \text{ M F}$ to force the current through the internal circuit; therefore, the internal and external resistances must always be added together and divided into the total $E \text{ M F}$ to find the current flowing. Now, if the internal resistance of the above cell were 0.5 ohm, the total

resistance would be $0.5 + 0.5 = 1$ ohm and $C = \frac{E}{R} = \frac{2}{1} = 2$ amperes, or half of the first result.

Ohm's law applies also to any part of a circuit the same as to the whole circuit. When applied to part of a circuit care must be taken to use only the $E \text{ M F}$, resistance, and current strength of that portion of a circuit considered. Therefore, when E is used as total $E \text{ M F}$, R must be the total resistance, and when E is used as the pressure applied to part of a circuit, R to correspond must be the resistance of that part of the circuit to which the E was applied. This application of the law may be illustrated by the following problem:

The $E \text{ M F}$ of a cell is 2 volts; its internal resistance 0.5 ohm. It is connected to three spools of wire in series. By measurement we find that the E causing the current to flow through one of the

spools, of which the $R=0.4$ ohm, is 0.6 volt. What current is flowing through this spool?

$$\text{By Ohm's law } C = \frac{E}{R} = \frac{0.6}{0.4} = 1.5 \text{ amperes.}$$

Now, since the current is the same in all parts of a series circuit, 1.5 amperes flow through each of the spools and also through the internal resistance. This also illustrates the difference between the E M F and potential difference. The difference of potential or pressure between the ends of the spool is 0.6 volt, while the E M F of the cell is 2 volts.

What part of the total E M F is used in overcoming the internal resistance of the cell in the above problem?

$$\text{By Ohm's law } E = C \times R = 1.5 \times 0.5 = 0.75 \text{ volt.}$$

This gives pressure lost or "volts drop" inside the cell.

Electrical resistance is the opposition offered by any conductor to the flow of a current through it. It is measured in ohms. The ohm is the resistance of a column of mercury about 42 inches high and 0.00155 square inch in cross-sectional area at zero centigrade. The resistance of any conductor increases with its length and decreases with the area of cross section, and for most conductors the resistance increases with rise of temperature.

ELECTROMAGNETISM.

Every wire through which a current flows possesses a magnetic field around it. This fact can be proved by bringing a compass near it. The magnetic field will act on the compass, and it will be deflected, showing not only the presence of a magnetic field, but also the direction of the lines of force. These will be found to encircle the wire, always running from left to right, similar to the direction in which the hands of a clock move, assuming that the current is flowing directly away from the observer.

A solenoid consists of one or more layers of wire wound on a spool, usually of nonmagnetic material, the length being great as compared with the diameter. A magnet can be made of a solenoid by passing a current of electricity through the wire. One end of the coil will be the north pole and the other the south pole. If an iron bar be placed lengthwise through the coil while the current is flowing, it will be found that the magnetism has been increased. This is due to the fact that lines of force are much more easily set up in iron or steel than in a nonmagnetic medium. A solenoid with such an iron core constitutes an electromagnet. The current's magnetic field induces magnetism in a piece of iron placed within its limits.

If the iron core of a solenoid is pulled out while the current is flowing the attractive force of the solenoid will tend to pull the core back until its middle point coincides with that of the solenoid. This principle is made use of in many electrical devices, such as circuit breakers, ammeters, and telautographs. Electromagnets are used in many kinds of instruments—electric bells, telegraph sounders, telephone receivers, and relays are some examples. The strength of any electromagnet depends on the number of turns of wire and the strength of current passing through it.

ELECTROMAGNETIC INDUCTION.

If a straight wire be moved across a magnetic field so as to cut lines of force, a difference of potential will be set up between its ends. If the ends of the wire be connected outside the field, a current will flow. This is called electromagnetic induction, and the currents so produced are induced currents. Upon this principle is based the operation of all dynamos, transformers, induction coils, telephones, etc.

No distinction is made between the magnetic field of a permanent steel magnet and that of an electromagnet. Either the magnetic field or the closed circuit may be moved so long as the lines of magnetic force are made to cut the wire of the closed circuit. Usually a coil with an iron core (electromagnet) is used to produce the induction. It is called then the primary coil, or simply "primary." The closed circuit, or the circuit under induction, is then called the secondary coil, or "secondary."

Current may be induced in the secondary by any of the following methods:

1. By moving either the primary or secondary while current is flowing in the primary.
2. By making or breaking the primary circuit.
3. By altering the current in the primary.
4. By reversing the direction of current in the primary.
5. By moving the iron core while current flows in the primary.

ELECTROSTATIC INDUCTION.

It has been found that an insulated conductor, such as a sheet of tin, an aerial-line wire, or a cable conductor, has the property of receiving an electrostatic charge when subjected to an electromotive force. If, for instance, a conductor of the type mentioned above be thoroughly insulated and one terminal connected to one side of a battery, the other side of which is grounded, a certain amount of electricity will flow into the conductor and appear upon its surface as an electrostatic charge, and the potential of the conductor will be raised to that of the

battery. The conductor in this condition is said to be charged and holds an amount of electricity, depending upon its capacity. The charge is of the same polarity as the terminal of the battery to which the conductor is connected.

Experiment has determined that a charge can not exist on a conductor except there be an equal and opposite charge induced upon the bodies surrounding it, and this second induced charge is always of opposite polarity to that of the first charge. If now the conductor be connected to the ground it will lose its charge, but the charge of opposite sign on the surrounding bodies will still be held, although having no connection with the first body or with the source of electromotive force. This action by which bodies are charged through an insulating medium constitutes electrostatic induction, and the arrangement of two insulated conductors separated by an insulated medium constitutes a condenser. The most common type of condenser is the Leyden jar, in which the insulated conductors are sheets of tin foil, one placed on the outside, the second on the inside of the glass jar, the latter forming the insulating medium or dielectric, as it is commonly called. The capacity of the condenser, or its ability to receive an electric charge, varies in direct proportion to the area of its plates inversely as the square of the distance between the plates and directly as the specific inductive capacity of the dielectric. Where air is used as the dielectric, this latter quantity is unity. The substances, other than air, ordinarily used as dielectrics have a specific inductive capacity of two to three times as great as that of air. Condensers used for telephone purposes where it is necessary to obtain considerable capacity in very limited space are commonly built up of alternate layers of tin foil and paraffined paper tightly pressed, so as to bring the layers of tin foil, which comprise the plates, as close together as possible. The condenser is very extensively used in telegraph and telephone work as a means of allowing alternating or pulsating currents to pass while preventing the flow of direct currents; this is the direct opposite of the functions of an impedance coil, which opposes a very high resistance to variable currents while offering little resistance to the flow of direct current.

PRINCIPLE OF THE TRANSFORMER.

An induction coil, or transformer, consists of two independent coils wound on the same iron core and insulated from each other and from the core. Alternating or interrupted currents in one of the coils (called the primary) produce a variable number of lines of magnetic force in the iron core and thus currents are induced in the other coil (secondary), so that any E M F that may be applied to the primary may be changed to a higher or lower one in the secondary. The ratio

of primary to secondary E M F is equal to the ratio of the turns in the two coils. For example, if there are 10 turns in the primary and 100 turns in the secondary, the induced E M F will be ten times greater than that used in the primary. When a low E M F in the primary is changed to a higher one in the secondary coil, the latter loses in current strength what it gains in pressure. For example in the above case, if there is 1 ampere current at 10 volts pressure in the primary and the E M F of the secondary is 100 volts, only 0.1 of an ampere of current would be flowing through the latter. This assumes that there are no losses in the transformer. This principle is made use of to generate very high electromotive forces capable of breaking down an air gap like the spark gap used in wireless telegraphy.

CHAPTER II.

BATTERIES.

There are two classes of batteries, viz, primary and secondary batteries, the latter class being sometimes known as storage batteries, or accumulators.

PRIMARY BATTERIES.

Primary batteries are divided into two groups known as closed circuit and open circuit batteries.

Closed circuit cells are adapted for supplying current continuously until the energy of the chemicals is nearly expended.

Open circuit cells are used for intermittent service where power is required only for short intervals of time, such as in electric bells. Open circuit cells kept in continuous service for some time become exhausted, but will recuperate on open circuit.

The dry battery is an excellent example of the open circuit type.

CLOSED CIRCUIT BATTERIES.

The gravity, Fuller, and Edison are types of closed circuit cells.

Useful data on the above types of cells are given in the following table:

Type of cell.	Voltage.	Weight.	Internal resistance.
Gravity.....	1.00	<i>Pounds.</i> 11½	<i>Ohms.</i> 3.0
Fuller.....	2.00	12	.2
Edison primary.....	.67	11	.07

GRAVITY CELL.

This is the form of primary cell most extensively used in telegraphy and telephony when a small but constant current is required. The usual form is shown in figure 1, consisting of a glass jar about 8 inches high and 6 inches in diameter. In the bottom are placed three strips of sheet copper, riveted together, as shown, with a rubber insulated wire attached to one of the strips. There are many forms of zincs, but the "crowfoot" is now almost universally used.

To set up the cell, place about 3 pounds of bluestone (sulphate of copper) in the cell after putting in the copper, then hang the zinc and fill with water. The bluestone should be allowed to settle without any attempt to dissolve it by stirring or other means. The cell or cells are then "short-circuited" (zinc and copper connected together) and allowed to stand several days. By that time part of the bluestone will have dissolved, the blue line being well defined. Above this will be a clear solution of sulphate of zinc, formed by the action of the battery, the sulphate of zinc, being of less specific gravity than the copper sulphate solution, will remain on top if the cell is not shaken or stirred up. The battery may now be put into service.

If in a hurry for the cell, it may be started off at once by stirring up about a tablespoonful of salt with the water before pouring it into the cell; but this method is apt to make a battery dirty and considerably shorten its period of usefulness. Any long, dark masses forming on the lower part of the zinc should be removed with a stick. The zinc sulphate solution will grow stronger and stronger, until finally the white salts will begin to creep or climb up the sides of the jar and the zinc. As they will corrode the connections and cause dirt and loss of insulation around the cells, they should be removed. Much of the trouble will be obviated if, as soon as they appear, part of the zinc sulphate solution is drawn off with a battery syringe or a siphon made of bent glass tube, and water put in its place. If the

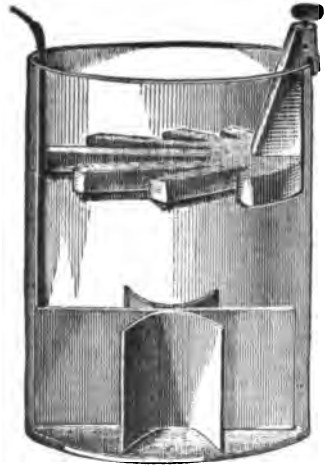

FIG. 1.

upper parts of the cells are warmed and smeared with paraffin, it will help matters. But the best plan of preventing evaporation and creeping of salts is to use a good quality of paraffin or lubricating oil, pouring on a layer about one-fourth inch thick as soon as the cells are set up. In cleaning cells after that wet cotton waste dipped in sand will clean the zincs, etc., of the adhering oil. The local battery, being much harder worked, requires renewing about every six weeks; a main-line battery will usually stand from four to six months. As soon as the blue solution goes down below the level of the copper, more bluestone should be added. Corrosion of the connections of the zincs with their wires should be carefully looked after. It is better to have routine inspections of batteries made, and, if possible, instrumental tests, made with the voltmeters (figs. 165 to 174) or voltammeters (fig. 191) furnished for that pur-

pose, should be carefully recorded. By this means, deterioration may be accurately noted and many annoyances, breakdowns, and delays which are frequently due to neglect and lack of regular inspection of the batteries may be avoided.

The internal resistance of a gravity cell in good condition will be found to be about 3 ohms, its E M F 1 volt.

EDISON PRIMARY BATTERY.

This battery is quite extensively issued by the Signal Corps and is known as the type V cell (fig. 2). The signal corps type V cell is a slightly modified form of the Edison Lalande cell. As manufactured for the Signal Corps, it has the same capacity as the old Edison Lalande cells, but its enameled steel jar is slightly conical, enabling the cells to be nested together for transportation. The caustic soda and oil for each cell are issued in tin cans, so that there is nothing that will not stand transportation. This cell has a very low internal resistance (not exceeding one-eighth ohm) and will remain set up on open circuit for a long time without injury. It will bear considerable transportation when set up if handled with care. It has a capacity of about one hundred and

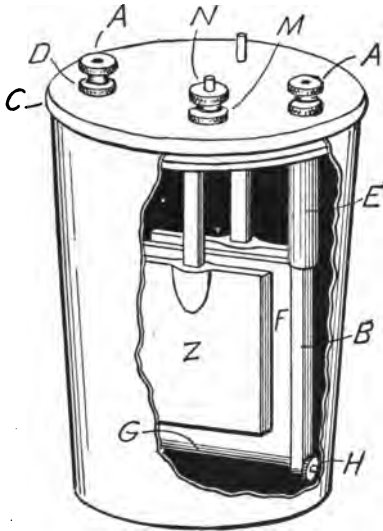

FIG. 2.

fifty ampere hours, which means that it will furnish about two hundred and ten days' continuous service on a main line where the current is 30 milliamperes and forty days' service as a local when the current is about 0.16 ampere.

It gives but 0.67 volt E M F in steady work. For main-line use, about 14 cells Edison battery are needed to replace 10 bluestone, but owing to its lower internal resistance one cell of Edison will give more current as a local cell with the 4-ohm sounder than a bluestone cell.

The following complete directions for setting up, management, and renewal of these cells are furnished by the company manufacturing them:

DIRECTIONS FOR SETTING UP AND USING EDISON PRIMARY BATTERIES, FORMERLY KNOWN AS EDISON LALANDE CELL TYPE V.

TO CHARGE AND CONNECT BATTERIES.

To make solution.—Fill the cells with water to $1\frac{1}{2}$ inches of the top on the inside.

Add the caustic soda gradually to the water, stirring until the soda is entirely dissolved.

When the solution cools, more water should be added to bring it up to $1\frac{1}{2}$ inches of the top. Then pour contents of bottle of heavy paraffin oil from bottle furnished on the solution to each jar.

NOTE 1.—The caustic soda will burn the skin and clothes. In stirring the liquid avoid splashing it.

To set up cells.—Unscrew the nut *N* and the jamb nut *M* from the screw on the brass neck of the double zinc plate and remove the leather washer. Pass the screw from below through the central hole in the cover *C*. Replace the leather washer and the jamb nut *M* on the screw and tighten down the jamb nut until the zinc plate is rigid to the cover. The thumb nut *N* can then be screwed on.

Unscrew the nuts *A A* and jamb nut *D* from the screws on the two side pieces *B B* of the copper frame, leaving the flat leather washers in position on the screws, and pass the screws from below through the two round holes in the cover *C*. Replace the jamb nut on one of the screws and one of the thumb nuts on the other screw, and tighten both down until the frame sides are rigidly clamped to the cover. Replace the other thumb nut on the screw holding jamb nut. Then slip the hard rubber insulating tubes *E E* over the sides of the frame, one on each side.

To fill copper frames.—(In this cell only one oxide plate is used. See fig. 2.) Slide the oxide plate *F* sufficiently far into the frame to enable the copper bolt *G* to be passed underneath it through the slots in the bottom of the frame sides and the copper nut *H* tightened up on same.

Be careful that the zinc plates do not touch the copper oxide plates or the cell will be short-circuited.

The copper connection is made between the thumb nut *A* and the jamb nut *D* on one end of the copper frame and the zinc connection between the thumb nut *N* and the jamb nut *M* on the brass bolts suspending the zincs.

After the oxide and zinc plates are properly connected to the cover, as above, soak them in water and while still wet insert in jar filled with caustic solution. (Wetting the plates prevents the oil in jar from adhering to them.)

Important.—In order to allow the cover on the jar to fit easily, it is advisable to wet the rubber gasket ring fitting into the grooved edge of the cover by placing it in water. This will cause the cover to slip on easily and will make the cell liquid tight.

It is absolutely necessary that the upper edge of the oxide plates should be submerged at least 1 inch below the surface of the caustic soda solution in the jar; also on no account can the layer of oil on top of the solution be omitted.

RENEWING.

When the cell becomes exhausted the solution and the remains of the zinc and oxide plates must be thrown away. The remaining parts can be used again.

TO TAKE THE CELLS APART.

Lift the lids, unscrew the bolts, and remove the zincs and oxide plates. Wash off (with water) the copper frames, bolts, and rubber insulators, brightening up the metal where corroded, with emery paper, especially the inside grooves of the copper frame sides. Pour away the solution carefully and set up cells with new caustic soda, oxide plates, and zincs according to directions.

NOTE.—In taking the cells apart, the parts that have been immersed in the caustic soda must be washed before they are handled.

TO ASCERTAIN IF THE OXIDE PLATES ARE EXHAUSTED.

Pick into the body of the oxide plates with a sharp-pointed knife. If they are red throughout the entire mass, they are completely exhausted and need renewing. If, on the contrary, there is a layer of black in the interior of the plate, there is still some life left, the amount being dependent entirely upon the thickness of the layer of black oxide still remaining.

COPPER FRAMES.

When renewing the battery it is desirable to clean the inside grooves of the copper frames, where the copper-oxide plates make contact, so as to insure a good electrical connection. This is especially important where the batteries are required to give a heavy current for cautery or motor purposes. These frames can be easily cleaned by wrapping a small piece of emery paper round a stick which will just fit into the groove, or by immersing them in a dilute solution of 1 part of sulphuric acid and 4 parts water, and then carefully rinsing them in clean water to remove all traces of the acid.

Caution.—The oxide plates should never be removed from the caustic soda solution and allowed to dry in the air, as, if this is done, the surface of the plates becomes oxidized by absorbing the oxygen from the air, and the oxide thus formed is much more difficult of reduction than the original oxide of which the plates are formed. The internal resistance is consequently very greatly increased and the current materially diminished.

NOTE.—Where batteries are placed in warm places they should be examined every two or three months to see that the solution has not evaporated, as this will gradually take place, in spite of the oil, if they are in a hot room. If the solution is found to have evaporated, add more water to bring it again to the proper height. It is of the first importance that all binding posts and connecting wires should be kept clean and bright at the points of connection.

FULLER BATTERY.

This belongs to the class popularly called "acid batteries." The cell has a high electromotive force, a comparatively low internal resistance (0.5 ohm), and is much used as transmitter battery on long-distance or heavily worked telephones. Its only disadvantage is that it uses a corrosive solution containing sulphuric acid, necessitating much care in handling. It consists of a glass jar about 8 inches high and 6 inches in diameter, with a wooden cover treated with asphaltum or P. & B. paint (fig. 3). This supports a carbon plate about 4 inches wide, 9 inches long, and one-fourth inch thick,

with the top coated with paraffin to prevent the corrosion of the connection by the acid. In the jar stands an earthenware porous cup $7\frac{1}{4}$ by 3 inches, in the bottom of which is placed about 2 ounces of mercury. In this stands a conical zinc, into which is cast a copper wire extending out at the top. In the glass jar is placed the "electropoion" solution, made by slowly adding 1 pound of strong sulphuric acid to 9 pounds of distilled water, and then stirring in 3 pounds of pulverized bichromate of potash or $2\frac{1}{2}$ pounds of bichromate of sodium. This last is preferable, as the crystals formed in the action of the cell are not so hard and insoluble as those produced by the potash. In the porous cell with the zinc and mercury is placed water in which about a tablespoonful of salt has been dissolved. This cell will usually require little attention for three or four months. When the solution assumes a muddy bluish tint, it is about exhausted.

If the copper wire at its junction with the zinc is covered with paraffin or ozite, or if the copper wire is well amalgamated by rubbing with mercury after dipping it into acid, the wire does not tend to be eaten off at the junction, as it otherwise does under heavy service. The Signal Corps issues the materials for the solution in dry form, which when dissolved form the electrolyte. This

is purchased under various commercial names as chromac, voltac, chromite, salts, etc., the first being the usual designation. It is packed in tin cans with thin cutout top containing 1 pound, which is the amount for one charge. Full directions for using are marked on each can.

The carbon of this cell lasts indefinitely, but should be soaked in warm water when renewals are made. The zinc may last through several renewals of the electropoion fluid. The mercury should be saved and used repeatedly.

The following table, quoted from Abbott's Telephony, indicates the effect of age on efficiency of transmission with the Fuller cell.

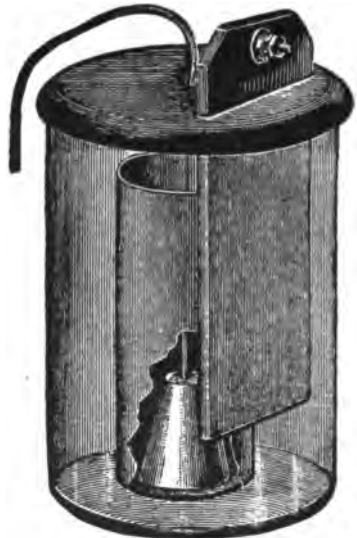

FIG. 3.

Two-cell Fuller battery.

Age.	Volume of transmission.
<i>Days.</i>	<i>Per cent.</i>
20	92
30	88
40	84
50	80
60	76
70	70
80	62
90	54

From this it would appear that the cells must be renewed at least once in three months when used on a telephone transmitter.

OPEN CIRCUIT BATTERIES.

Dry cells.—The dry battery is being very extensively used in connection with signal corps field and fire control telephone work. While all cells of this type conform in general to the following description, it is found that different makes vary widely in efficiency. In order to demonstrate the comparative merits of each make, a careful life test is undertaken annually in the signal corps laboratory, Washington, D. C., the results of which determine approved makes of cells for the coming year.

The dry battery is a form of sal-ammoniac battery in which the zinc constitutes both the containing vessel and negative element, doing away with the breakable expensive glass cell. Some absorbent porous material fills the space between the carbon in the center, with its depolarizing mixture around it, and the zinc vessel. This porous material is saturated with a solution containing chloride of zinc and salammoniac, and a top of asphalt or similar material is put on. Binding posts for zinc and carbon and a pasteboard cover to prevent short-circuiting of adjacent cells complete this convenient form of battery. When these are of reasonable size (say not less than 20 cubic inches in volume), are carefully made, and properly stored, they are fairly reliable. They can not, like the wet batteries, be renewed, but their cheapness offsets this. A short run of usefulness, after they are exhausted and can not be replaced, may be obtained from the cells in this way: Punch a number of holes through them and use these dry cells as elements in a wet cell by placing them in jars with a solution of salammoniac. A salt solution may be used, but is not so good.

The results of field work, supplemented by the regular battery tests, have demonstrated that the round type of dry cell is more efficient than the rectangular type. This is due to the uniform distribution of the active material with respect to the elements in the former type of cell.

RESERVE TYPE DRY CELL.

The ordinary type of dry cell deteriorates if kept long in storage, even though not in use. To provide a type of dry cell which could be kept in storage without deterioration, the Signal Corps issues a dry cell known as the "reserve type," shown in figure 4. This cell, although containing all the elements and ingredients of an ordinary dry cell, does not become active until water has been poured into an interior cavity of the cell. To place the cell in service, remove the

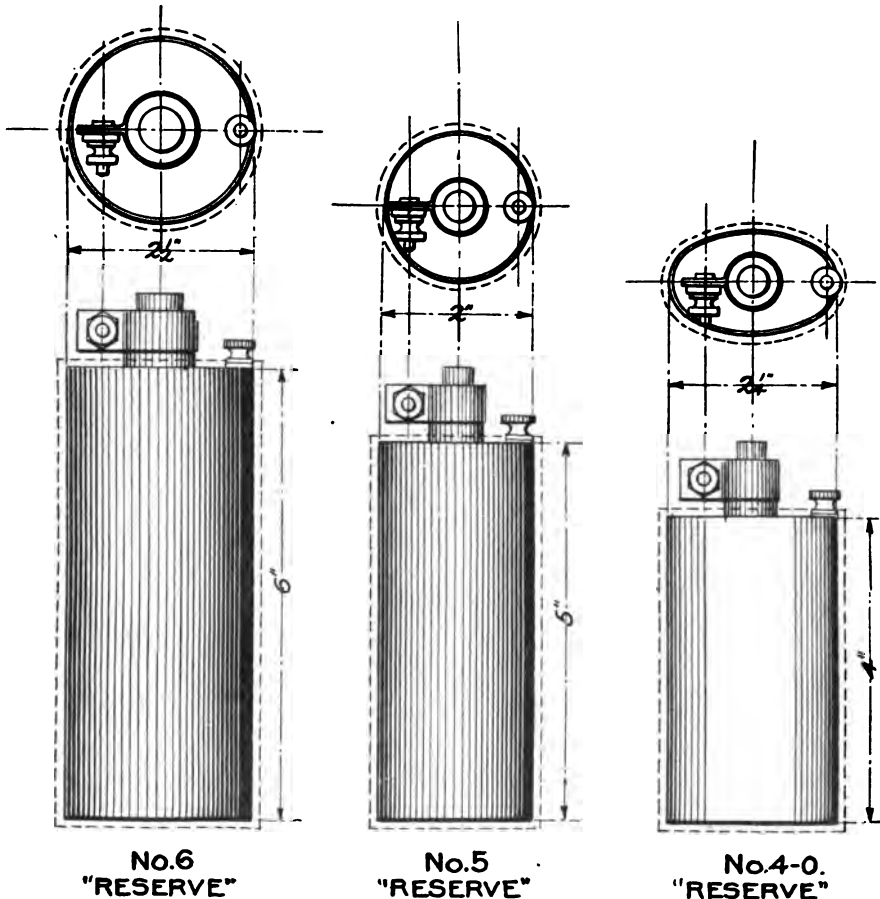

FIG. 4.—Reserve dry cells.

plug from the top of the carbon element and fill with water (rain water preferred). As soon as this is absorbed, fill again, and repeat until it will take no more water, then throw out the excess water from the carbon element, replacing the plug, and the cell is ready for use. When the cell becomes weak from use, a little sal-ammoniac solution placed inside the carbon element will rejuvenate the cell to some extent.

DRY CELLS FOR CAVALRY BUZZERS.

A special type of dry cell is issued for use in cavalry buzzers. This cell differs from the other types of dry cells issued by the Signal Corps only in the shape of the cell. Each battery contains two rec-

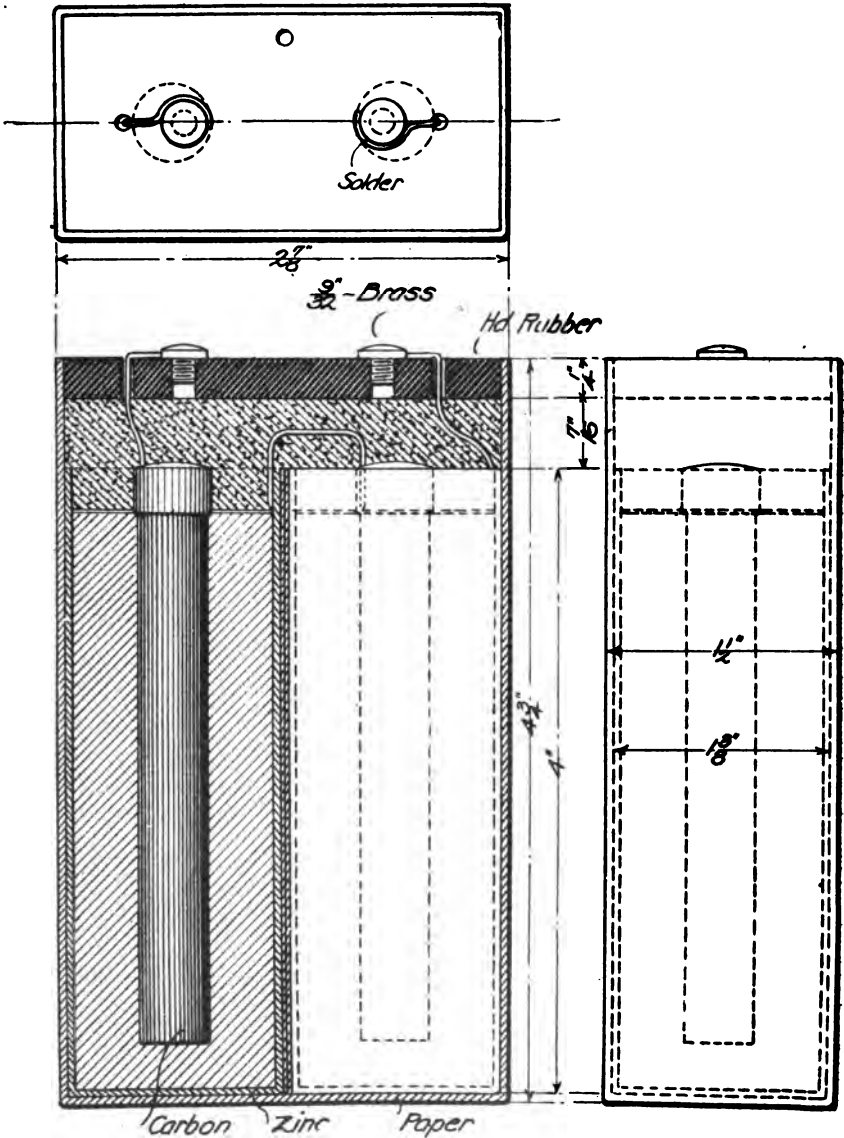

FIG. 5.—Cavalry buzzer dry cell.

tangular cells combined in one package, as shown in figure 5, giving a voltage of about 2.9. The two cells are connected in series beneath the cover and two terminal posts are exposed for making connection with the proper contacts in the cavalry buzzer.

DRY CELL FOR FIELD ARTILLERY TELEPHONE.

The "Ever Ready" type of dry cell is used for the field artillery telephone. The cells are small cylinders and are grouped into batteries by superimposing cells, one upon the other, in a stiff paper tube; a small battery of high voltage is thus obtained, as each cell gives about 1.5 volts. Two cells, $1\frac{1}{2}$ by 3 inches, are assembled to make the complete battery.

Dry cells in good condition have a voltage of about 1.45. The internal resistances and weights of the various types are about as follows:

Size.	Internal resistance.	Weight.
	<i>Ohms.</i>	<i>Ounces.</i>
4-0	0.25	11 $\frac{1}{2}$
4	.25	9
5	.20	18
6	.20	32
7	.12	56
8	.10	80
4-0, reserve	.29	11 $\frac{1}{2}$
5	.22	18
6	.19	32
Cavalry buzzer battery.....	.35	29
Field artillery telephone battery.....	.40	4 $\frac{1}{2}$

Dry cells of the number and size of the following table are issued with instruments in all cases except the composite artillery type telephone:

Allowance of dry cells required by instruments.

Instrument.	Type of cell.	Number of cells.
L. B. post telephone switchboards.....	No. 8, reserve.....	(a)
Portable field telephone switchboard.....	No. 6, reserve.....	2
L. B. telephones for post use.....	No. 4-0, reserve.....	2
Field telephones, models of 1905 and 1906.....	No. 6, reserve.....	2
Field buzzers.....	do.....	2
Cut-in telephones.....	No. 4-0, reserve.....	5
Service telephones, (folding-box pattern).....	do.....	4
Induction field-telegraph set.....	No. 6, reserve.....	2
Cavalry buzzer.....	No. 5, reserve.....	4
Field artillery-type telephone.....	Special.....	b 1
Field artillery telephone, model 1910.....	No. 4-0, reserve.....	2
	Ever ready.....	b 1

^a Supply only when directed.

^b One unit consisting of two special cells.

GROUPING OF CELLS.

When it is necessary to cause a certain current to flow through a considerable resistance, as a long telegraph line, for instance, the necessary E M F is obtained by connecting cells in series—that is, the copper of one cell to the zinc of the next, and so on until the requisite E M F is obtained, the relatively small increase of the total resistance

due to the internal resistance of the cells being of little effect. The total voltage is the sum of the voltages of all the units so connected. But when it is desired to get a certain current through a low resistance, another grouping must be made. The internal resistance of the ordinary gravity cell is about 3 ohms. And with its one volt E M F the current through a short thick wire of no appreciable resistance connecting its poles will be one-third ampere. And if we have 100

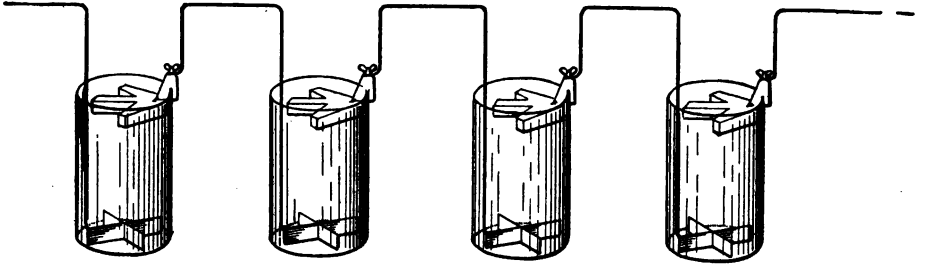

FIG. 6.

cells in series and connect the terminals of the entire battery, we would get $\frac{1}{3}$ ampere, or one-third as before. For any number of these cells in series, to obtain an increased current through low external resistance, we must cut down the internal resistance of our battery. This, with a given type of cell, may be done by linking them in parallel—that is, by connecting all the zincs together and all the coppers together and then connecting the multiple zinc and multiple

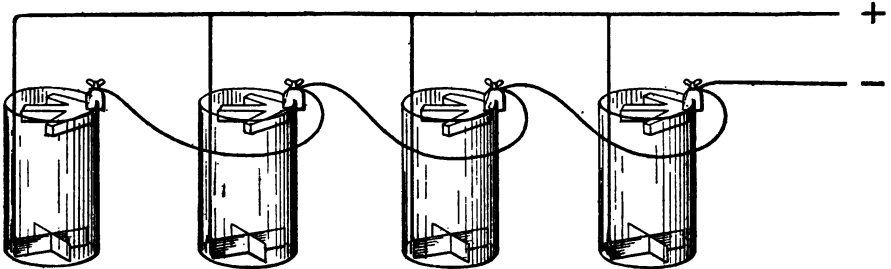

FIG. 7.

copper thus obtained to the low external resistance. The E M F of the battery remains the same as that of one cell, but the current output is now equal to the sum of the current capacities of all the units so connected. The two diagrams (figs. 6 and 7) illustrate, first, four cells connected in series; the second, four cells in parallel.

In the first case we should get a current of $\frac{1}{3}$ ampere through our short circuit; and in the second case, $C = 1 \div \frac{3}{4} = \frac{4}{3}$ ampere.

SECONDARY BATTERIES.

Secondary batteries in the form of storage batteries, or accumulators, are used by the Signal Corps to supply the necessary power for telephone, telautograph, and telegraph installations where a charging circuit is available. The storage battery differs from the primary battery in its action only that, when it has given out all the energy the chemicals present enable it to supply; instead of requiring new elements the cell can be regenerated, or brought back to its original charged condition, by passing a current into it in a direction opposite to that in which the flow took place on discharge. Although there are many obvious combinations which can be used for storage batteries, practically all those in commercial use and all those installed by the Signal Corps are of the lead-sulphuric acid kind, which in its basic principle consists of two lead plates immersed in dilute sulphuric acid.

All the storage batteries erected by the Signal Corps thus far are the standard types of commerce. In fire-control installations at sea-coast fortifications 15 cells are installed as a battery for supplying current for telephone systems; 60 cells are installed for telautograph installations, and for telephone installations at interior posts 12 cells are installed for a battery. The normal E M F of a storage cell while discharging is 2 volts, so that the voltage of the batteries can be easily computed. Storage batteries have the virtue of a high E M F low internal resistance, cleanliness, and certainty in action, making them very advantageous to use where the necessary charging circuit is available.

The principle involved in the storage battery is the change produced by the charging current which alters the chemical condition of the two plates. When the charging current is discontinued the cell will give off a current in the reverse direction and the plates tend to resume their original chemical condition when discharged. The positive plate will be known by its chocolate brown aspect, whereas the negative plates are gray. The frames, or grids, of the plates for lead batteries are made of pure lead or lead alloy, not readily attacked by inert sulphuric acid. The positive plate is impregnated with lead peroxide and the negative plate with pure, or sponge lead. The theory of the chemical action of the cell is that on charge the positive plate becomes peroxide of lead and the negative plate becomes pure lead and on discharge both plates tend toward the condition of lead oxide (PbO). Another theory advanced is that sulphate of lead is made on both plates by discharging and that during the charge lead peroxide (PbO_2) is formed on the positive plate and pure lead (Pb) on the negative plate, sulphuric acid being set free.

In later paragraphs on the maintenance of storage batteries emphasis is laid on the fact that storage batteries should not be allowed to remain in a discharged state. This is because lead oxide immersed in sulphuric acid will be chemically attacked, independent of any current flow, and change into lead sulphate, so that discharged plates tend to take on a coating of lead sulphate, a nonconductor, impairing the efficiency of the cell as an accumulator.

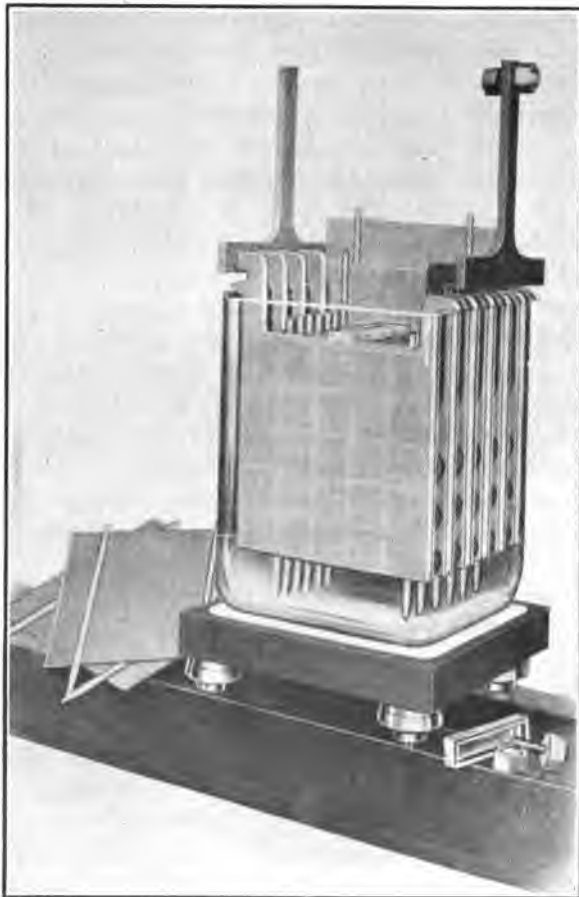

FIG. 8.—Electric Storage Battery Company's chloride cell.

Various methods of manufacture are used to give the plates more current capacity—that is, to expose more reducible peroxide of lead in the positive and spongy lead in the negative plate to the action of the electrolyte. The various methods of manufacture consist in changing the form of the grids and different methods of filling them with the oxides and spongy pure lead. Inasmuch as neither of these have any mechanical strength in themselves, the grids or frames are necessary to make up a suitable electrode.

Different makes of storage batteries are used by the Signal Corps, but to date all those used are of the lead types made by the Electric Storage Battery Company, known as the "Chloride" battery; those made by the Willard Storage Battery Company and known as the

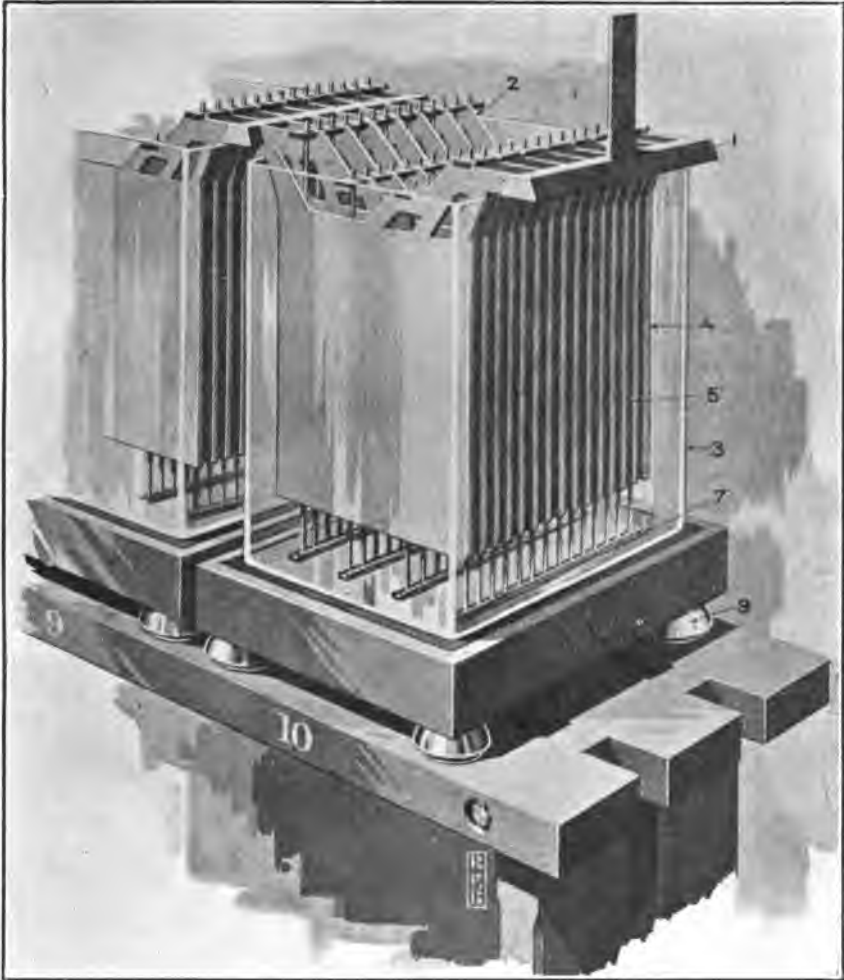

FIG. 9.—Willard storage cell.

"Willard;" and those made by the Gould Storage Battery Company, known as the "Gould" batteries. (See figs. 8, 9, 10.)

Although these batteries all depend on the same chemical action, the different mechanical features in the forms of grids, spongy lead, and peroxide of lead seem to give the several batteries characteristics that require different procedure in their erection, initial charge, and

operation and maintenance, and the methods recommended by the different companies as affecting their products will be outlined hereafter.

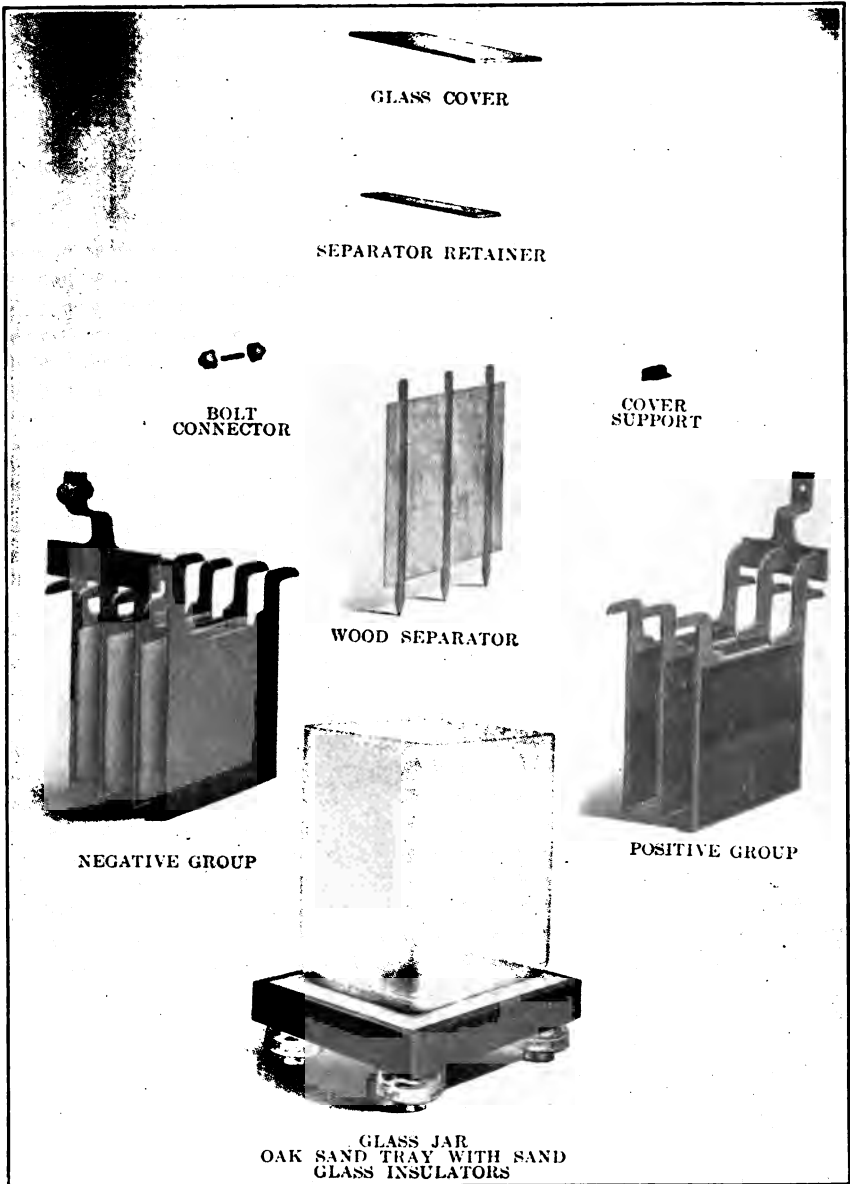

Fig. 10.—Gould storage cell.

TABLE OF RATINGS.

The ampere hour capacity and sizes of batteries can be determined by the table herewith, covering all the makes and types of storage batteries used by the Signal Corps.

To determine the normal charge and discharge rates of a battery multiply the "amperes per positive plate" for the particular type in question by the number of positive plates per cell; thus for a type F battery of 13 plates per cell (6 positives and 7 negatives) the normal rate is 60 amperes.

Size of plates, not including lugs.	Normal charge rate (8 hours) per positive plate.	Type.		
		Gould.	Chloride.	Willard.
	<i>Amperes.</i>			
3 by 4 inches.....	1	• W	• BT	• CC
5 by 5 inches.....	1½	• X	• CT	• DC
5 by 8½ inches.....	3	• Y	• PT	• BC
7½ by 7½ inches.....	4½	• Z	• ET	• EC
6 by 6 inches.....	2½	M	D
7½ by 7½ inches.....	5	N	E	E
11 by 10½ inches.....	10	O	F	F

* Two-plate types.

EDISON STORAGE BATTERIES.

Another type of storage battery, which is not considered in this chapter, is the Edison battery, which has recently been developed and placed on the market. The active materials are oxides of nickel and iron in the positive and negative electrodes, respectively. The grids are made of nickel-plated steel, and the electrolyte is a solution of caustic potash and water. These cells have a normal E M F, when fully charged, of 1.2 volts, and are charged at about 1.7 volts. Although not as efficient as the lead types of storage battery, they are advantageous for vehicle purposes, as it is claimed the output per unit of weight is nearly twice that of lead cells. None of this type of battery has been installed by the Signal Corps.

INSTRUCTIONS FOR ERECTING STORAGE BATTERIES.

Storage batteries, when received at storerooms, should be placed in a dry location and an effort made to erect the batteries as soon as possible after their receipt. When unpacked preparations should be made to handle each group of elements as a unit. Lift the contents out of the boxes; never slide them out by turning crate on its side. Wood separators should be unpacked as soon as received and not allowed to dry under any circumstances. They should be kept in water until installed, or kept damp by frequent sprinkling. After the lead elements are unpacked, care must be used in handling so that the plates and lugs will not be bent or broken. This can be done by lifting the plates with a stick under all the lugs of each element, which can then be lowered carefully in the jars. Care must be used to prevent breaking the tank or jar, or bending the plates of

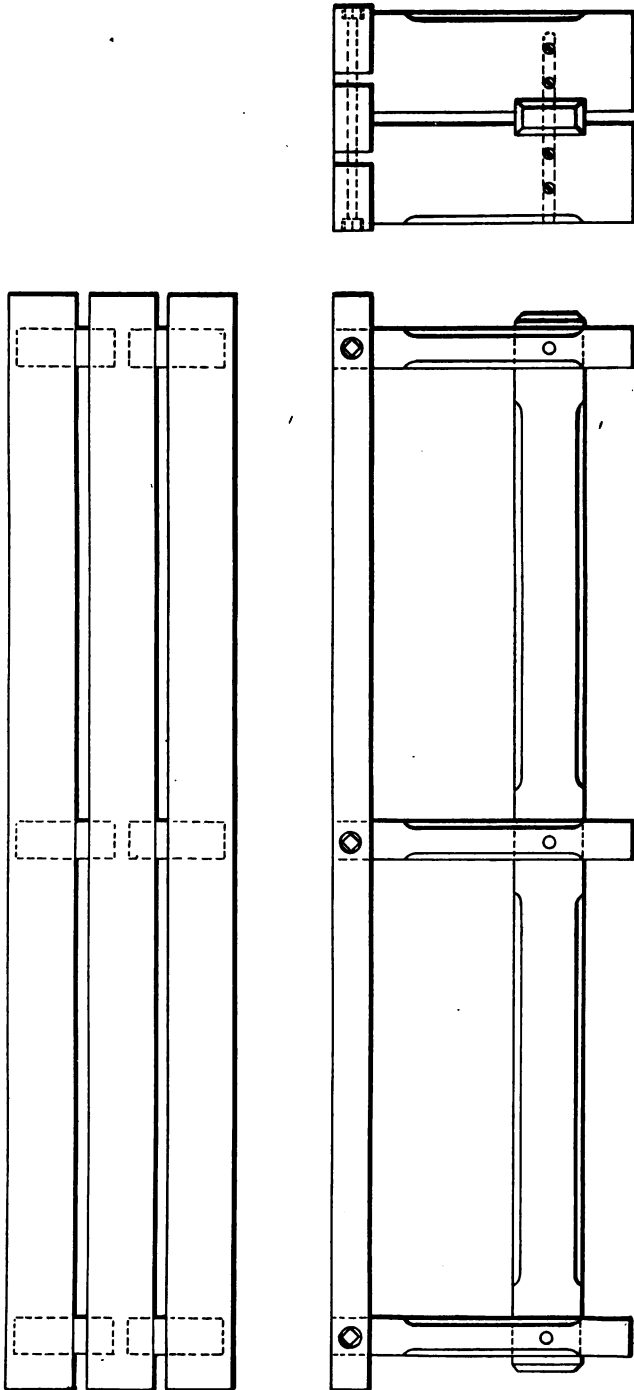

FIG. 11.—Rack for small storage batteries in glass jars and sand trays.

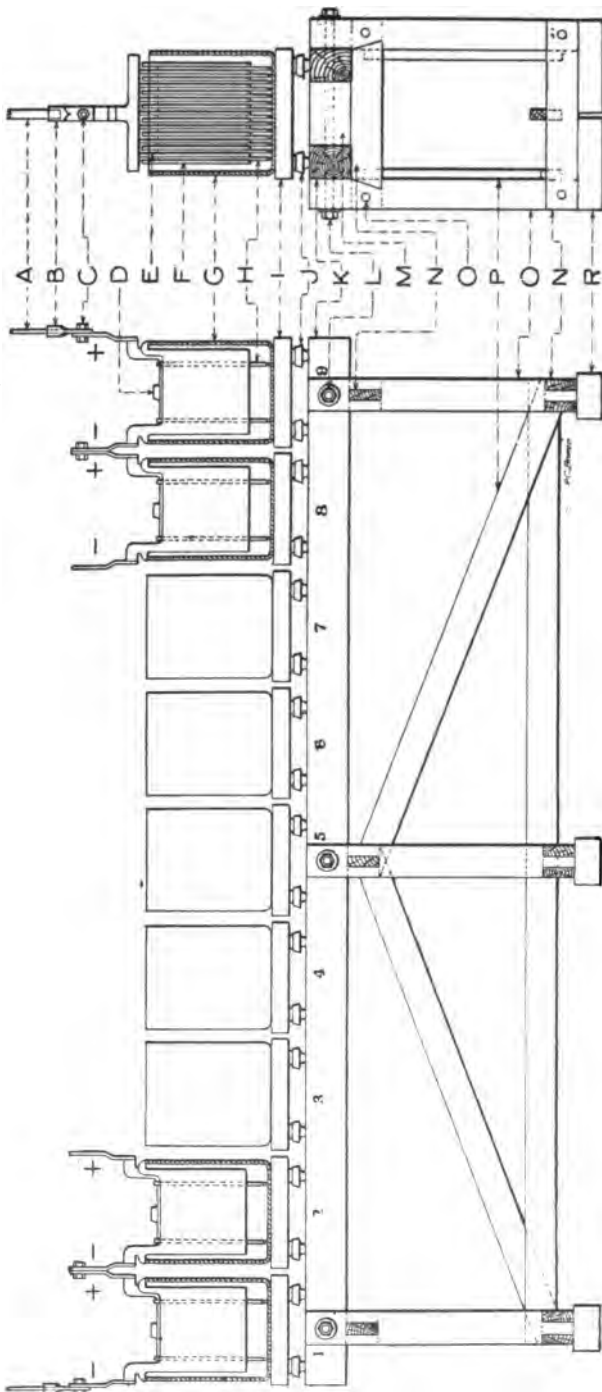

FIG. 12.—Typical storage battery installation on wood rack.

supporting lugs. Types of storage battery racks suitable for cells of the sizes installed by the Signal Corps are shown in figures 11 and 12. These can be made of any sound timber with the necessary strength, which can be secured locally; all boltheads carefully puttied over, the whole given several coats of acid-proof paint. The rack is then located in its permanent position, and if the battery room has an asphalt floor, provision is made for wide bases for the uprights of the rack to prevent them sinking into the floor. The rack should be carefully leveled before the batteries are installed. The stringers must be of sufficient strength to support the cells rigidly and perfectly level. The insulators should be placed, and the wood tanks or

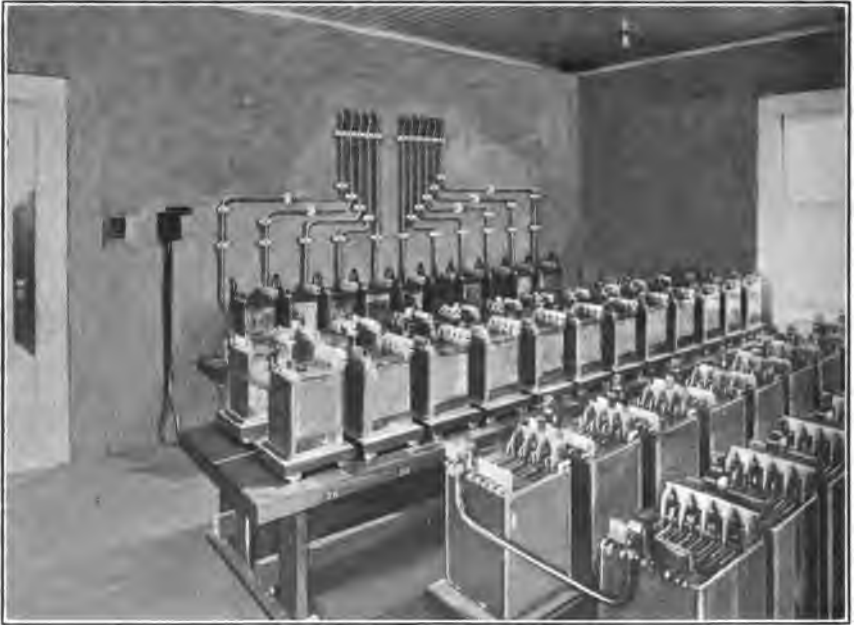

FIG. 13.—End-coil cabling—telautograph storage battery.

sand trays and glass jars carefully aligned, care being taken that they do not touch each other. If bolt connections are used, they should be thoroughly cleaned by scraping. The strap lugs should also be scraped where they will be in contact, and all connections bolted tight and then painted with an insulating paint. The leads to the storage battery from the switchboard room should be lead-covered cable if possible. The sheath should be cut back about 8 inches from the terminal lugs, which are sweated on by heating and filling the hole with melted resin solder into which the wire is forced after being carefully cleaned and tinned. The insulation and the shank of the lug is then carefully taped up and given several coats of acid-proof paint. Where the lead rises from the floor loricated conduit

can be installed to protect it from injury. Lead-covered cable should be used as couplings between adjacent banks of batteries and should be thoroughly painted. End-cell cabling should be run in a symmetrical manner through porcelain cleats by which the cables are carried to the point to which they are to be connected (see figure 13). The sand trays and sand must be carefully dried before being installed. The trays can be dried by ordinary methods, but the sand must be baked for a sufficient time to insure that all moisture has been expelled. Before commencing the initial filling of the jars with electrolyte, if wood separators are used, they should be installed and arrangements should be made to do the work rapidly. Sufficient glass or earthenware jars must be available so that several men can carry and empty the electrolyte, and a platform erected upon which the carboys can be tipped and handled with safety. It is essential that the electrolyte be kept clean during this process, and every precaution should be taken to that end. Electrolyte of the proper specific gravity is furnished with each battery by the maker. Care should be taken to ascertain that a sufficient amount of electrolyte of the correct specific gravity is available before the filling is commenced. It should be known with absolute certainty that the required power for the necessary length of time will be available before an initial charge is commenced. The maximum voltage available for charging should be at least 2.75 volts for every cell to be charged, and the amperage available that required by the type of cell.

OPERATION AND MAINTENANCE.

A storage battery will give very little trouble if the instructions for its operation and maintenance are faithfully followed.

The following general instructions are recommended by the several manufacturing companies for the operation and care of the storage cells manufactured by them, in telautograph, telegraph, and telephone service:

INITIAL CHARGE.

It is of the utmost importance that the initial charge be complete in every respect before the battery is put into service.

Before the electrolyte is put into the cells, the circuits connecting the battery with the charging source must be complete and of the proper polarity. The positive pole of the charging source must be connected with the positive end of the battery. The positive plates are of a brownish color, the negative of a light gray. Charging in the reverse or wrong direction will seriously injure the battery. If a suitable voltmeter is not at hand, the polarity may be determined by dipping two wires from the charging terminals into a glass of water to which a teaspoonful of table salt has been added, care being taken to keep the ends at least an inch apart to avoid danger of a short circuit; as an extra precaution, a lamp may be inserted in one leg of this circuit. Fine bubbles of a gas will be given off from the negative pole.

As a guide in following the progress of the charge, readings of the current, specific gravity, and voltage should be taken and recorded at not greater than half-hour intervals. The gassing should also be watched, and if any cells are not gassing or are not gassing as much as the surrounding cells, they should be carefully examined and the cause of the trouble removed.

The temperature of the electrolyte should be closely watched, and, if it approaches 100° F., the charging rate must be reduced or the charge temporarily stopped until the temperature lowers.

The specific gravity will fall rapidly after the electrolyte is added to the cells, and will then gradually rise as the charge progresses until it is up to 1.210, or thereabouts. The voltage of each cell at the end of charge will be between 2.50 and 2.70 volts, and for this reason a fixed or definite voltage should not be aimed at.

If the specific gravity of any of the cells at the completion of the charge is below 1.205, or above 1.215, for chloride batteries, allowance being made for the temperature correction, it should be adjusted to within these limits, adding electrolyte of 1.210 specific gravity, if low, and replacing some of the electrolyte in the cell with water if high, keeping the surface at the proper height above the top of the plates.

INITIAL CHARGES FOR DIFFERENT MAKES OF CELLS.

The different manufacturers recommend different methods of proceeding in the initial charges of their batteries, which should be carefully followed, as this is the only means by which they can be held responsible for the conduct of their cells, which are sold on guaranties.

For a "chloride" battery the charge should be started at the normal rate as soon as the electrolyte is in the cells (covering the plates about three-fourths inch), and continued at the same rate until both the specific gravity and voltage show no rise over a period of ten hours, and all the plates are gassing freely. Electrolyte of 1.170 specific gravity is furnished for the type BT, CT, PT, and D cells and of 1.210 specific gravity for all the other larger types. The positive plates will gas some time before the negatives. To meet these conditions, from fifty to sixty hours continuous charging at the normal rate will be required for the larger cells, while the types BT, CT, PT, and ET require from thirty to forty hours for the initial charge; and if the rate is less, the time required will be proportionately increased. In case the charge is interrupted, particularly during its earlier stages, or if it is not started as soon as the electrolyte is in the cells, the total charge required (in ampere hours) will be greater than if the charge is continuous and started at once.

For this operation the Willard Storage Battery Company recommends as follows:

The charge must be commenced immediately upon filling the cells with electrolyte of 1.200 specific gravity. The battery should be charged at a rate equal to two-thirds of its normal or eight-hours charging rate. The charging should be continued until the voltage of each cell is 2.6 volts, the reading being taken while the battery is being charged at the above rate. After the cells have

reached the voltage named above, or higher, the charge should be continued until the specific gravity of each cell ceases to rise, or has remained constant for at least three hours. This will usually happen after a battery has been charged for approximately sixty hours. The experience of the Signal Corps has been that a longer period of charge is required. If any cells do not show the proper rise in voltage, or do not gas freely, they should be examined. Care should be taken that there are no internal short circuits. If there are, they should be removed at once, and the charge continued until the cells indicate as above.

The Gould Storage Battery Company recommends the following procedure for the initial charge of their batteries:

Fill the cells with the electrolyte furnished with a specific gravity of 1.210. Commence initial charge at twice the normal or eight-hour rate and continue for twelve hours, then reduce to 1.4 times the normal charge rate for twenty hours, then decrease to the normal or eight-hour rate and charge for twenty hours. The specific gravity should be about 1.210 at the end of charge corrected to temperature.

OPERATION.

Excessive charging must be avoided, nor must a battery be undercharged, overdischarged, or allowed to stand completely discharged.

Pilot cell.—A cell, to be designated as the "pilot cell," should be selected and used as a guide in the operation of the battery. The cell selected should be readily accessible, but preferably not one at the end of a row. If, however, the plates in the battery are not all of the same age, the pilot cell should be a cell containing the oldest plates. Readings are to be taken on this cell with sufficient frequency to indicate its state of charge and discharge, which will thus serve as a guide in the operation of the battery as a whole. The pilot cell, when once selected, should not be changed unless the cell has to undergo special treatment or repairs. The height of the electrolyte in this cell should be kept at a fixed point, three-quarters inch above the top of the plates. A small quantity of water must be added by hand often enough (at least once a day) to keep the height accurately at the proper point. This will prevent the sudden drop in the specific gravity of the electrolyte consequent upon the addition of a considerable quantity of water and the following increase in gravity as it slowly evaporates. The fixed point should be marked in a convenient manner; for instance, in a glass-jar battery by a painted line on the outside of the jar, or for tanks an S-shaped strip of lead hung over the edge of one of the glass-supporting plates.

For batteries not equipped with the full number of plates, the range in gravity on charge and discharge is necessarily reduced, due to the proportionately greater amount of electrolyte. As it is of advantage to have as great a range as possible in the pilot cell, in order to reduce the percentage of error in reading the hydrometer, in such batteries the pilot cell should have the excess electrolyte displaced. A

specially constructed tank for this purpose is used in batteries set up in tanks; if in glass jars, a wooden block properly treated and weighted is used.

Charging, general.—The battery should preferably be charged at the normal rate. It is important that it should be given the proper amount of charge, as indicated below, but excessive charging must be avoided, as not only will rapid accumulation of sediment and excessive evaporation of the electrolyte result, but, what is more important, the life of the plates will be very much shortened.

Both from the standpoint of power economy and life of the battery the best practice is the method which embraces what may be called a "regular charge," to be given when the battery is from one-half to two-thirds discharged, and an "overcharge" to be given weekly if it is necessary to charge the battery daily, or once every two weeks if the regular charge is not given so often.

As a general rule it will be found advisable not to charge until the specific gravity of the pilot cell has fallen to the following limits: If the cells have the full number of plates, or if there is a displacing tank in the pilot cell of a partially filled battery, 15 points below the maximum gravity attained on the preceding overcharge; if only partially filled with plates, with no displacing tank, then 10 points below the maximum gravity. Thus, if the maximum gravity attained on the overcharge is 1.209, start charging when the gravity has fallen to 1.194 and 1.199, respectively. These limits provide for a reserve in emergency cases and also prevent unnecessarily frequent charging. If the voltage method only is used for observing the charge and discharge, no single rule can be given for determining when the charge is to be started, as the voltage varies with the rate of discharge.

The reading of the specific gravity of a pilot cell or of the voltage of the battery can be used as a guide in following the charge. The specific gravity method is to be preferred, owing to its being independent of the rate of charge, the voltage method being used as a check on the gravity or in cases where, due to the character or inaccessibility of the cells, the specific gravity method is not practicable.

Regular charge.—The battery should be charged at or as near the normal rate as possible, until the following conditions are fulfilled:

(a) The gravity of the pilot cell having risen to a point which is 5 points (0.005 specific gravity) below the maximum reached on the preceding overcharge.

If the cells are but partially filled with plates and the excess electrolyte is not displaced, the limit should be 3 points (0.003 specific gravity) instead of 5 points (0.005 specific gravity).

(b) The voltage across the battery having risen to a point which is 0.05 to 0.10 volt per cell below what it was on the preceding overcharge, the charging rate should be the same in both cases; for instance,

if the maximum voltage per cell attained on the overcharge is 2.52, the voltage per cell to be reached on the regular charge is from 2.42 to 2.47 volts per cell.

(c) The cells all gassing moderately.

Overcharge.—Once every two weeks, and on the same day of the week, the regular charge should be prolonged (always at the normal rate) until the following conditions are fulfilled:

(a) The gravity of the pilot cell having reached a maximum, five successive fifteen-minute readings of this cell showing no further rise.

(b) The voltage across the battery having reached a maximum, five successive fifteen-minute readings showing no further rise, the charging rate being kept constant.

(c) Inasmuch as most signal corps storage batteries only require recharging about once a week, an overcharge should be given every two weeks.

Battery charged in parallel.—In installations where the battery is charged in parallel, being divided into two equal series for this purpose, care should be taken that the charging rate is the same in each series, equalizing apparatus, if necessary, being used for the proper adjustment of the current, which should be at the normal rate in each series.

The completion of charge is then determined in the same manner as if all of the cells were charged in one series.

Voltage at end of charge.—The voltage at the end of charge throughout the life of a battery is not a fixed voltage, but will vary, due to several causes, namely, the age of the battery, the temperature of the electrolyte, and the charging rate; therefore a fixed voltage must not be considered when using the voltage method in determining the end of charge.

When first installed, the voltage at the end of overcharge, with current at normal rate, will be not less than 2.5 volts per cell for Willard cells, 2.55 volts for "chloride," and 2.63 for Gould cells, with the temperature at 70° F., but as the age of the battery increases this voltage gradually lowers until, in some cases, with both the charging rate and temperature normal, it will have fallen to 2.40 volts per cell or thereabouts.

The effect of changes in temperature on the final charging voltage is that it is noticeably lowered with an increase in the temperature above normal (70° F.) and correspondingly increased with lowered temperatures in respect to the age of the battery.

Higher or lower rates than normal will, respectively, produce slightly higher or lower final charging voltages.

Voltage and specific gravity after charge.—After the completion of a charge and the current is cut off, the voltage per cell will fall immediately to about 2.20 volts, and then quite rapidly to 2.05 volts,

at which point it will remain while the battery is floating at zero current or is on open circuit.

When the discharge is started the voltage will at once fall to about 2 volts per cell, or slightly under, depending on the rate of discharge.

Also, after the completion of a charge, particularly an overcharge, the specific gravity of the electrolyte will rise slightly, due to the passing off of the gas bubbles formed during the charge; for this reason all of the pilot cell gravity readings must be taken before the charging current is cut off.

Discharging.—During the greater part of a complete discharge the drop in voltage is slight and very gradual, becoming greater with marked rapidity near the end.

The safe limit of discharge is reached when the voltage has fallen to 1.80 volts per cell with current flowing at normal rate (at higher rates the limiting voltage is somewhat lower); in usual service, however, with the rate at or near normal it is advisable to stop the discharge at about 1.90 volts per cell, this higher voltage insuring a reserve in case of emergency. If the discharging rate is considerably less than the normal, the voltage should not be allowed to fall as low as 1.90 volts per cell, for the reason that with a very low rate of discharge the voltage will not begin to fall off until the limit of capacity is almost reached.

The fall in specific gravity of the electrolyte also serves as an indication of the amount taken out and is in direct proportion to the ampere hours discharged, thereby differing from the drop in voltage, which varies irregularly for different rates and degrees of discharge, and for this reason under ordinary conditions the fall in gravity is to be preferred in determining the amount of discharge.

The actual amount of variation in the gravity of the electrolyte between a condition of full charge and a complete discharge is dependent upon the quantity of solution in the containing vessel compared with the bulk of the plates.

When cells are equipped with the full number of plates, the range will be about 35 points (0.035 specific gravity); for instance, if the maximum gravity reached on the preceding overcharge is 1.209, the extreme limit beyond which the discharge should not be carried is about 1.174. If the cells have less than the full number of plates, this range in gravity is proportionately reduced, except in the case of the "pilot cell," which should be equipped with a device for displacing the excess electrolyte.

The available capacity is temporarily reduced at low temperatures; with a return to normal temperature the capacity is regained.

Readings.—In addition to the required signal corps records the following suggestions are made: As a guide in following the opera-

tion and general condition of the battery, and also for a record of the same, it is important that readings be regularly taken and recorded.

The specific gravity of the pilot cell or the voltage across the battery, or both, should be read and recorded just before the beginning and end of every charge, and readings should also be taken hourly during the charge.

On days when the battery is not charged the gravity should be read and recorded at the usual time of starting the charge.

Just before the overcharge, at the same hour each time, a gravity reading of each cell in the battery should be taken and recorded. At the end of the overcharge a voltage reading of each cell should be taken while the current is still flowing and also recorded; voltage readings should never be taken with the battery on open circuit, as such readings are of no value.

The above cell readings should be carefully examined, and any cell showing a falling off in specific gravity or voltage relative to the surrounding cells should be noted and inspected as soon as possible and the cause removed.

In addition to the above readings the temperature of the pilot cell should be read and recorded at least once each day, preferably at the end of charge.

Figure 14 illustrates the readings and results of efficiency tests made on a battery installed as part of a fire-control system. The curves shown indicate the voltage characteristics on normal charge and discharge rates.

CARE OF THE BATTERY.

Inspection.—A careful inspection of each cell should be made periodically. This is very important, as it is bad practice to wait until trouble develops and then hunt for the cause. The most suitable time for an inspection is just before the overcharge, so that if any trouble is discovered it can be removed in time for the cell to get the benefit of the overcharge.

If the elements are equipped with wood separators, an ordinary incandescent light on an extension cord can be used to advantage in making the inspection, and a careful examination should be made between the hanging lugs to see that they are in place and not touching the adjoining lugs; also anything unusual in the color or appearance of the plates should be carefully noted. An examining lamp and cord are provided in fire-control switchboard rooms. If the elements are in glass jars with other than wood separators, the lamp should be held at side of the bottom of the jar, so that by looking down between the plates any material that may have lodged across can be discovered and removed. If the elements are in lead-lined or all-metal tanks with other than wood separators, a submerged lamp is provided for inspection between the plates, and also to note

EFFICIENCY TEST OF TELEPHONE STORAGE BATTERIES

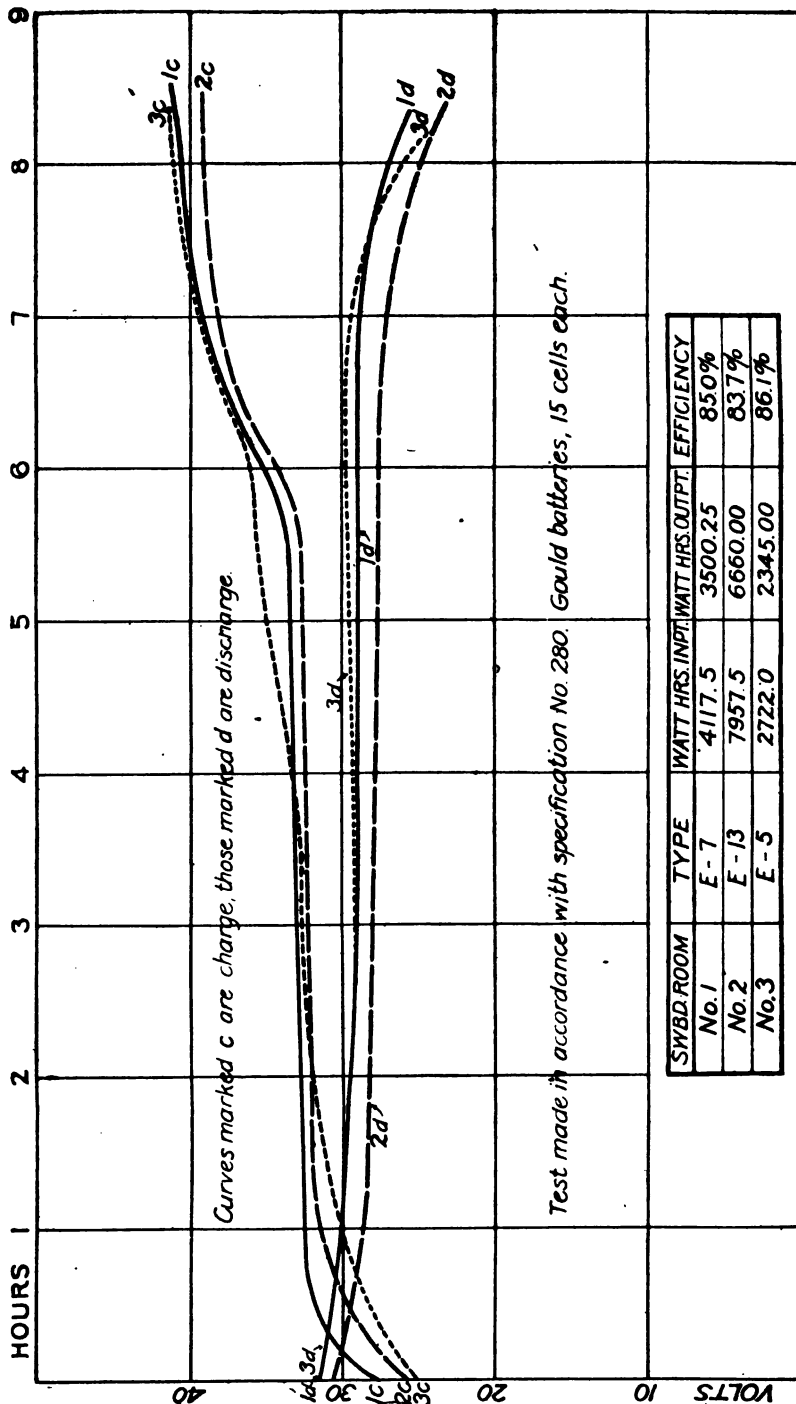

FIG. 14.

that the outside plates do not touch the ends of the tank; this also applies where wood separators are used.

Special attention should be given to cells that read low in specific gravity or voltage at the time the cell readings were taken. Look for the cause and remove it as soon as possible and not later than the beginning of the overcharge. Short-circuits should be removed with a thin strip of wood or rubber; never use metal.

Near the end of the overcharge all cells should be looked over to see that they are gassing freely.

If an accumulation of mossy material develops on the top of the negative plates, this should be removed before it bridges across to the adjoining plates and forms a short-circuit; such an accumulation results from excessive overcharging.

In addition to the above, the accumulation of sediment in the bottom of the cells should from time to time be noted; it must not be allowed to reach the plates.

Low cells.—The following are the chief indications of trouble in a cell:

Falling off in specific gravity or voltage relative to the surrounding cells.

Lack or deficiency of gassing on overcharge as compared with surrounding cells.

Color of plates markedly lighter or darker than in surrounding cells.

In case of any of the above symptoms being found in a cell, examine carefully for cause and remove at once.

Treatment.—The above symptoms in a cell indicate that it has fallen below the rest in its state of charge. If the cause is discovered and removed immediately it will usually be restored to normal condition by the following overcharge. If then only partially restored, it must be carefully watched during the ensuing week. If the next overcharge does not completely restore it, or if the original deficiency was excessive, it may be necessary to give it a separate charge.

Separate charging.—The first and simplest method of separate charging is to overcharge the battery, but care should be taken not to carry this to excess.

The second is by cutting the low cell out of circuit for several discharges and in again just before beginning the following charges. This method can be used to advantage when the elements are bolted together.

The third method is by giving an individual charge while the battery is either on discharge or standing idle. This charge can be given from the charging generator either by reducing the field excitation or through a water rheostat.

Before putting a cell that has been in trouble into service again, care should be taken that the cell has been fully charged, this being determined by continuing the charge until five successive hourly readings of both the gravity and voltage show no increase and there is free gassing from the plates and they are of normal color.

Sediment.—The accumulation of sediment in the bottom of the cells must be watched carefully and removed when the clearance has been reduced to one-half inch below the bottom of the plates; under no circumstances must it be allowed to get up to and touch the plates, as, if this occurs, rapid deterioration will result. Very often it will be found that the depth is greatest under the middle plates, and if the sediment is leveled over the bottom of the cell, its removal will not be necessary for some time longer. The leveling can be done by using an L-shaped device containing no metal in its construction.

To remove the sediment, the simplest method, if the battery has bolted connections between the cells, is after fully charging the battery, to lift the elements out of the jars, draw or pour off the electrolyte carefully; dump the sediment; clean with water; then replace the elements and cover quickly with electrolyte, adding enough new to replace that lost. The elements must not be exposed to the air except for the very shortest possible time, and must not be allowed to dry out in the least; for this reason only one cell should be emptied, cleaned, and refilled at a time.

If the cell connections are burned together the sediment can be taken out by using a special form of scoop for drawing it from beneath the plates and then removing it from the jar or tank. The wood separators, if the elements are thus equipped, should be temporarily drawn up so that the dowels will not interfere with the manipulation of the scoop. The separators should be handled carefully to avoid breakage.

A third method is to draw off the electrolyte and flush the cell with water (using the local supply) in such a way that the sediment will be continually stirred up; at the same time a siphon, inserted at the bottom of the cell, and with such capacity as will keep up with the water supply, should be started; the more rapid the flow in and out, the better. This operation should be continued until the cell is entirely free from sediment. The water should then be withdrawn and the cell immediately refilled with electrolyte. Do not allow the plates to dry out in the least. (See "Treatment of dry plates.") This method is usually only to be preferred when the cells are very large and where there is a strong head of water for stirring up the sediment.

In connection with the removal of the sediment, it will be necessary to provide some new electrolyte to be added to the old to make up for that absorbed and displaced by the sediment.

Immediately after the battery is cleaned and the new acid added, it should be given a long charge, continuing until every cell is fully charged.

Electrolyte—General.—Electrolyte is dilute sulphuric acid, prepared by mixing suitable commercial sulphuric acid, or “oil of vitriol,” as it is more commonly called, with pure water. It is essential that both the acid and water should be free from impurities, such as iron, arsenic, nitric or hydrochloric acid.

The proportions of acid (of 1.840 specific gravity or 66° Beaumé) and water in preparing electrolyte of 1.210 specific gravity are one part of acid to five parts of water, by volume. The acid must be added to the water slowly and with great caution, not only to prevent excessive heating, but more particularly splashing, on account of the painful and dangerous character of acid burns. Never add water to pure acid, as it is dangerous. The final gravity of the solution must be read when it has cooled. The vessel used for mixing must be a lead-lined tank, one of glazed earthenware, or one of wood which has not been used for any other purpose, such as a new washtub or spirits barrel. Never use a metal vessel. Electrolyte for maintenance will be furnished having a specific gravity of 1.400 as required for Willard and Gould cells. For “Chloride” cells it should be diluted with distilled water until the specific gravity is reduced to 1.210.

Specific gravity.—The specific gravity of the electrolyte of a cell in good condition when fully charged and at normal temperature (70° F.) should be about 1.200 for Willard and 1.210 for “Chloride” and Gould cells. Due to loss through spraying at the end of charge and to absorption by the sediment, there is a gradual lowering of the gravity, its rapidity depending on the work and care the battery is receiving. Acid of 1.200 specific gravity for Willard cells and 1.210 specific gravity for Gould and “Chloride” cells, should be used when filling the cells for the initial charge.

Unless a compensating hydrometer is used, allowance must be made for temperature variation on the basis of an increase of one point in gravity for each three degrees Fahrenheit decrease in temperature, and vice versa; for instance, electrolyte that is 1.210 at 70° F. will be 1.213 at 61° and 1.207 at 79°.

Restoring lowered specific gravity.—When, due to the above causes, the gravity of the electrolyte at the end of an overcharge and at normal temperature has fallen below 1.190, it should be brought up to standard by the addition of electrolyte instead of water when replacing evaporation.

Never under any circumstances add electrolyte to a cell in which short-circuits, high temperature, or partial charge may account for the low gravity.

Replacing evaporation.—Only pure water, preferably distilled, should be used to replace evaporation. It is advisable that a few samples be tested from time to time. The electrolyte must never be allowed to get below the top of the plates, nor must the cells be filled too full. The water should be added (at the top of the cells) with sufficient frequency to keep the electrolyte about three-fourths inch above the top of the plates; it should be added carefully and splashing or slopping avoided. The most suitable time for adding water is just before the overcharge, provided it is not necessary to add it more frequently, in which case it should also be added before a regular charge.

Impurities.—Should it be known that any foreign matter has gotten into a cell, steps should be taken to remove it at once. In case removal is delayed and a considerable amount of impurity becomes dissolved in the electrolyte, it should be entirely replaced with new, flushing the cell with water before putting in the new electrolyte. The change should be made when the battery is discharged and just before charging. Do not allow the element to dry. If in doubt as to whether the electrolyte contains impurities, a sample, taken at the end of discharge, should be tested. (See "Tests for purity of electrolyte.")

GENERAL.

THE BATTERY ROOM—VENTILATION AND TEMPERATURE.—That the temperature may be moderate and the air dry, the battery room must be properly ventilated, not only to insure dryness, but to prevent chance of an explosion, as the gases given off during charge form an explosive mixture if confined. For this reason never bring an exposed flame near the battery when it is gassing. Suitable outlets should always be provided for ventilating the battery room or cabinet.

To obtain the best results the temperature should be between 50 and 80° F. If the room temperature is very high—that is, over 80° F., for any great length of time, the wear on the plates is excessive. If the temperature is low, no harm results, but the available capacity is reduced during the period of low temperature.

Almost equally important with the temperature is the question of dryness, and the circulation of air should be sufficient to keep the stands, insulators, and cells free from dampness, which is very liable to cause grounding of the battery itself or its connecting circuits.

Light.—The provision for illumination should be such that all parts of the battery can be readily inspected at any time, day or night. If direct sunlight falls on the cells, the window panes should either be coated with white paint or be of frosted glass.

Cleanliness.—The battery room and the apparatus therein should be kept clean; if the floor, metal work, stands, insulators, trays, or tanks become coated with acid-laden moisture, wash them with a

saturated solution of bicarbonate of soda in water, which will neutralize the acid; then rinse with fresh water and open all the windows to allow of complete drying. The washing solution must not be allowed to get into the cells.

Protective coatings (paint, etc.).—To properly preserve the woodwork and metal work in the battery room, care must be taken to keep these parts well protected, particularly the wood boxing of the lead-lined tanks if the battery is thus installed.

The woodwork being thoroughly painted at the start, oiling at frequent intervals with boiled linseed oil, applied with a cloth rather than a brush, is recommended; repainting will then be necessary less frequently. The best paint is one with a heavy asphaltum base.

For metal work (copper and iron) also use the above paint; in addition, coat the connections with vaseline. If corrosion starts, at once thoroughly clean and repaint; in cleaning remove the corrosion by scraping and then washing with bicarbonate of soda solution. Do not at any time allow either the corrosion or the washing solution to fall into the cells.

Connections.—Keep all connections clean and tight. Inspect at regular intervals.

Covers.—To reduce the diffusion of acid spray, the amount of evaporation, and the danger of foreign matter falling into the electrolyte, covers may be laid across the top of the cells, these covers consisting of a thin sheet of glass or hard rubber. They should be so dimensioned that a free space is left at the front of the tank to allow of taking gravity readings and replacing evaporation without the necessity of removing the covers. They must never be allowed to overhang the ends of the cell; this to prevent dripping on the floor of the acid-laden moisture collected on the under side.

The covers should be removed when making an inspection. (See "Inspection.")

Oil or paraffin should not be used on the surface of the electrolyte.

Repair to jars or tanks.—If a jar is broken or a tank leaking, so that it has to be removed for repairs or renewal, the plates should be taken out, the negatives being immediately placed in a vessel containing clean water or in the free space of adjacent cells; the positives can be allowed to dry. The wood separators, if the battery is thus equipped, should first be removed and stored in the free space of adjacent cells; this should be done carefully, to avoid breakage. Broken or damaged separators should be discarded and new ones provided in their place. The utmost care should be taken that neither the negative plates nor the wood separators be allowed to dry out in the least.

Upon completion of repairs the plates and wood separators should be replaced (just before the charge is started) and immediately cov-

ered with electrolyte; the plates will then receive the benefit of the following charge.

Treatment of dry plates.—If for any reason the negative plates of a cell have been allowed to dry a long time will be required for recharging, the time being the same as that for an initial charge. For this reason drying of the negative plates is, as far as possible, to be avoided.

Positive plates, if dry, will require but a comparatively short charge; if they are in a fully charged state when taken out of a cell, from six to eight hours will be sufficient; if discharged, then somewhat longer.

In any case both the positive and negative plates of a cell must be fully charged before being put into regular service again.

If new plates are installed the amount of charge noted above will likewise be required.

Battery or individual cells used but occasionally.—If the battery is used but occasionally or is standing idle it should be given a partial discharge and recharge every four weeks; this also applies to any cells that may be temporarily out of circuit. Many signal corps storage installations are not used sufficiently for good maintenance, and an artificial discharge through a water rheostat or otherwise is very essential to keep the cells in good condition.

Where a battery is worked but very lightly it may not give full capacity at once if there is a call for a heavy discharge, due to the active material in the plates becoming "sluggish;" in such cases, if practicable, it is advisable, from time to time, to give the battery a special discharge, taking out from one-half to two-thirds the capacity.

End cells.—End cells are provided on each telautograph battery, intended to be thrown into the discharge or charge circuit at will. On discharge it is possible with these cells to maintain a practically constant voltage that is required for the satisfactory operation of telautographs. As the voltage of the main cells decreases additional cells are thrown into the discharge circuit by the use of an end cell switch, as will be explained later. From this it will be seen that some of the end cells will be used but little, and the main precaution in their maintenance is to be sure that they are not continually overcharged.

Provision is made on the telautograph switchboards for reading the voltages of the individual end cells, and these and specific-gravity readings, which should be taken before each charge, will give the condition of the end cells and determine the necessary charge which should be given them.

Arrangements should be made to give the end cells an artificial discharge if they do not get sufficient work to keep them in good condition, as it should be remembered that storage batteries require discharges as well as charges to keep them in condition.

PUTTING BATTERY OR INDIVIDUAL CELLS OUT OF COMMISSION.

If a battery will not be used for six months or longer, the battery should be put out of commission in the manner outlined hereafter for the different makes of batteries. When cells are taken out of commission, the dry plates should never be allowed to come into contact.

The Electric Storage Battery Company advises the following method for "Chloride" cells:

After thoroughly charging and determining that there are no low cells, syphon off the electrolyte (which may be used again) into convenient receptacles, preferably carboys, thoroughly cleaned, and as each cell becomes empty immediately fill it with fresh, pure water. When water is in all the cells, allow them to stand twelve or fifteen hours, then draw off the water. The cells will then be in condition to stand indefinitely. The carboys in which the acid is stored should be tightly corked to keep out impurities.

If equipped with wood separators, these should be removed just before drawing off the water; and if they are in good condition, and it is desired to use them again, they should be kept submerged in water.

If there is any considerable amount of sediment in the cells, advantage should be taken of the out-of-service period to clean them thoroughly.

Putting battery or individual cells into commission again: Fill the cells (to three-fourths inch above the top of the plates) with the electrolyte one after another as quickly as possible. (Some new electrolyte will be required to replace that lost in handling.) When all are filled the charge should be started. This charge is similar to the initial charge of a new battery. The rate should be normal and continue until the specific gravity and voltage have ceased rising for a period of ten hours. From thirty to forty hours at the normal rate will be required to complete this charge. If the rate is less than normal, the time required will be correspondingly increased. It is of the utmost importance that this charge be complete.

If wood separators are used, these should be put into place before the electrolyte is poured, each cell, however, being filled as soon as its separators are in position, so that they will have no chance to dry. If part new and part old separators are used, these should not be mixed, but kept together in cells by themselves, putting all of the new ones in one end of the battery and all of the old ones in the other end.

The Willard Storage Battery Company's instructions for taking a battery out of commission are as follows:

Putting the battery out of commission.—First give the battery a complete charge, then syphon off the electrolyte into convenient receptacles, preferably carboys (being careful to not use carboys which have had other kinds of acid than sulphuric in them unless thoroughly cleaned). As each cell is emptied of electrolyte, it should be immediately refilled with water. After filling with water the battery should be discharged until voltage is below one volt per cell at the normal discharge rate, after which the water may be drawn off and the battery may stand until put into service again.

Putting the battery into commission again.—In putting a battery into use again it should be treated in the same manner as a new battery. Care should be taken that the polarity of the charging source has not been changed.

To take the Gould batteries out of commission the following instructions apply:

To take battery out of commission.—Fully charge the battery, then remove the acid from all cells, each cell to be filled with clean water as soon as the acid is removed. Immediately after filling each cell with water discharge the battery at normal rate until the voltage reaches zero. (It will be necessary to short circuit the battery at the latter end of the discharge to get the voltage down to its proper value.) The water may then be removed and the plates stored in a convenient, dry place, keeping positive and negative plates separate, or, if desired, the plates may be left in their containing tanks.

The following summary applies to the operation and maintenance of all batteries installed by the Signal Corps, and these rules with additional information showing the normal charge rate and usual days of charge and discharge should be posted in every battery room:

SUMMARY OF IMPORTANT POINTS.

Excessive charging must be avoided, nor should a battery be undercharged, overdischarged, or allowed to stand completely discharged.

Keep the electrolyte at the proper height above the top of the plates. Use only pure water to replace evaporation. Never add acid, except under conditions as explained in the preceding instructions.

The daily and weekly readings should be regularly and accurately taken and recorded.

Inspect each cell of the battery carefully at regular intervals.

If any low cells develop, do not delay in bringing them back to condition.

Do not allow the sediment to get up to the plates.

Do not allow impurities, either solid or liquid, to get into or remain in the cells.

Have the battery room well ventilated, especially while charging.

Never bring an exposed flame into the battery room during or shortly after the gassing period of a charge.

Keep the floor and other parts of the battery room clean and dry.

Keep all the iron, copper, or other metal work about the battery free from corrosion.

Keep all the connections clean and tight.

Make out reports required by the signal corps carefully and regularly.

Telegraph batteries.—As telegraph batteries are frequently quite high in voltage, the insulation of the battery should be looked to. If the small porcelain or glass insulators for each cell are furnished, so

much the better; if not, the shelves should be as well insulated as possible, or strips of glass or small strips of paraffined wood under each cell may be used in an emergency.

In charging some of the smaller types of cells a convenient arrangement is represented in figures 15 and 16. In this the electric-light mains are connected with the storage cells with some incandescent lamps in parallel, as shown. If 32-candlepower carbonized filament

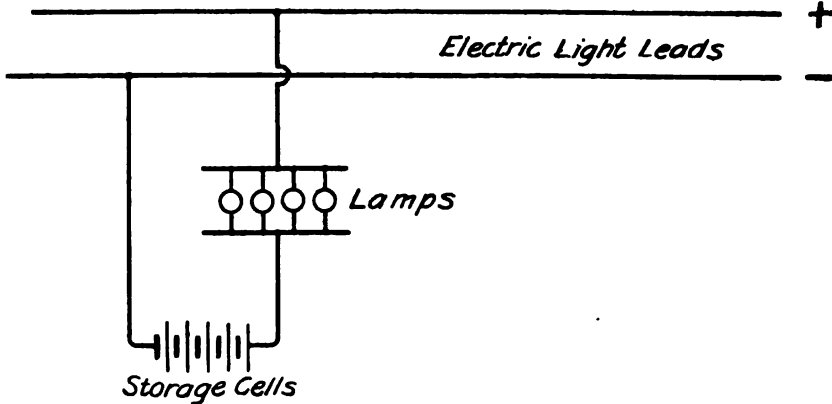

FIG. 15.

lamps are used, each lamp allows 1 ampere of current to pass. So with a type of cell requiring 6 amperes 6 lamps in parallel would permit the required current to pass. Of course the source of supply must be a direct, not an alternating, current.

The diagrams (figs. 15 and 16) show the arrangement for an office where a constant-current lighting circuit is available as a supply.

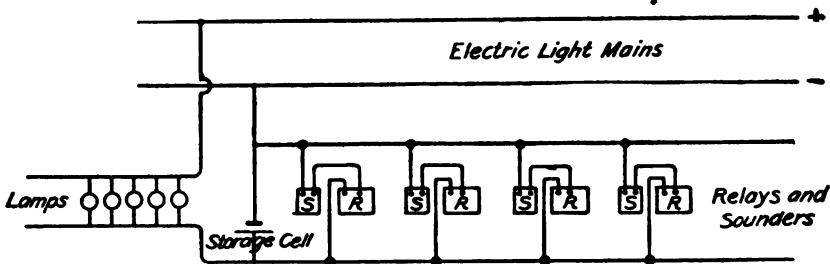

FIG. 16.

The lamps may be used to illuminate the office, as the opposing E M F, of the one-storage cell (fig. 16) will not perceptibly diminish their light. As will be noted, the storage cell is constantly in use even while charging.

On account of its low internal resistance, as many sounder circuits in parallel can be fed from one of these storage cells as the capacity of the battery will permit. Each sounder requires one-fourth ampere,

so in twenty-four hours it would require at most 6 ampere hours to supply it. And if the storage cell had a capacity of 50 ampere hours it could supply four sounder circuits twenty-four hours and still have a reserve for another day in case of accident to the charging circuit.

The method of tapping off various voltages from a number of storage cells in series for the different lines is shown under the heading of switchboard diagrams.

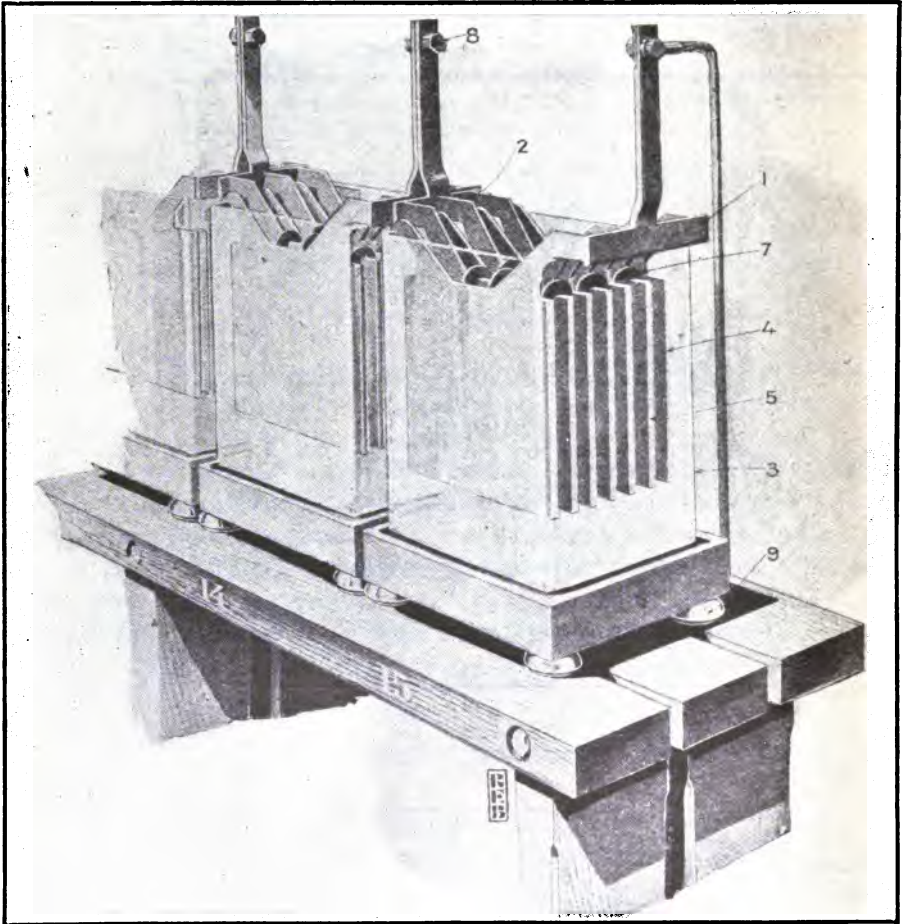

FIG. 17.—Typical battery installation.

Telephone batteries.—As stated previously, telephone batteries at coast artillery posts consist of 15 cells, and at interior posts of 12 cells. These vary in size from ET to E-11 “Chloride” batteries or their equivalents. Fire-control telephone installations at coast-artillery posts are designed to operate at 30 volts, and the post-telephone systems derive their current from the same source, leads being run from the switchboard rooms to the headquarters building, in which the telephone switchboards are usually located. These telephone

batteries are usually installed in glass jars on a suitable rack, and figure 17 illustrates an installation of this type. The size installed varies with the requirements of each system. At interior posts the telephone batteries are usually installed in the switchboard room at central and vary in size to fit the installation in question, E-5 being the largest, and in most cases the 2-plate types being installed. Type PT, "Chloride" cells, or equivalents, in glass jars, will be standard hereafter for small interior posts. The method of installing telephone storage batteries will be taken up more fully in the chapter on telephone switchboards.

The size of storage cell for telephone switchboards is not determined solely by the amount of circuit required, but must also be large enough so that the internal resistance is negligible, as otherwise this common resistance might be the source of cross talk in the system. It is also essential that the current be always available, so that it is not unusual to provide duplicate batteries so that one may be repaired or dismantled if necessary.

Figure 18 indicates the apparatus and circuit assembled on a small switchboard supplied for interior post telephone installations of the kind described. From an examination of the circuit it will be seen that the charging direct current is controlled by the incandescent lamps to meet the particular size of cells charged, and that only one set of batteries can be charged or discharged at a time. The condition of the batteries is indicated, as far as possible, on the voltmeter in the usual manner.

Telautograph batteries.—For the telautograph equipment installed as part of fire-control installations, various types of storage batteries are provided, ranging from E-9 to F-15 "Chloride" cells, or their equivalents in Willard or Gould cells, the size depending on the number of telautographs to be operated, and the other demands of the fire-control installation. The motor generators for charging the telephone batteries and operating the time interval bell circuits of these installations are usually fed from the telautograph battery. Sixty cells comprise these batteries, 10 cells on one end being controlled by a 10-point end-cell switch, so that any number of cells from 50 to 60 can be charged or discharged as desired. This enables any number of cells or the required voltage to be thrown on the telautograph lines, which usually operate at about 115 volts. The F-type batteries are usually installed in lead-lined wood tanks, on a suitable wooden rack designed to carry the weight and afford the required insulation. Figure 13 illustrates a typical telautograph storage-battery installation, and shows the cabling for the end cells from the rack nearest the wall. Inasmuch as the usual post power available is at a potential of 110 volts, it is necessary to increase this to as much as 170 volts (see preceding instruction) to charge the 60 cells of

telautograph battery. This is done by the use of motor generators or boosters, which increase or alter the voltage of the charging circuit.

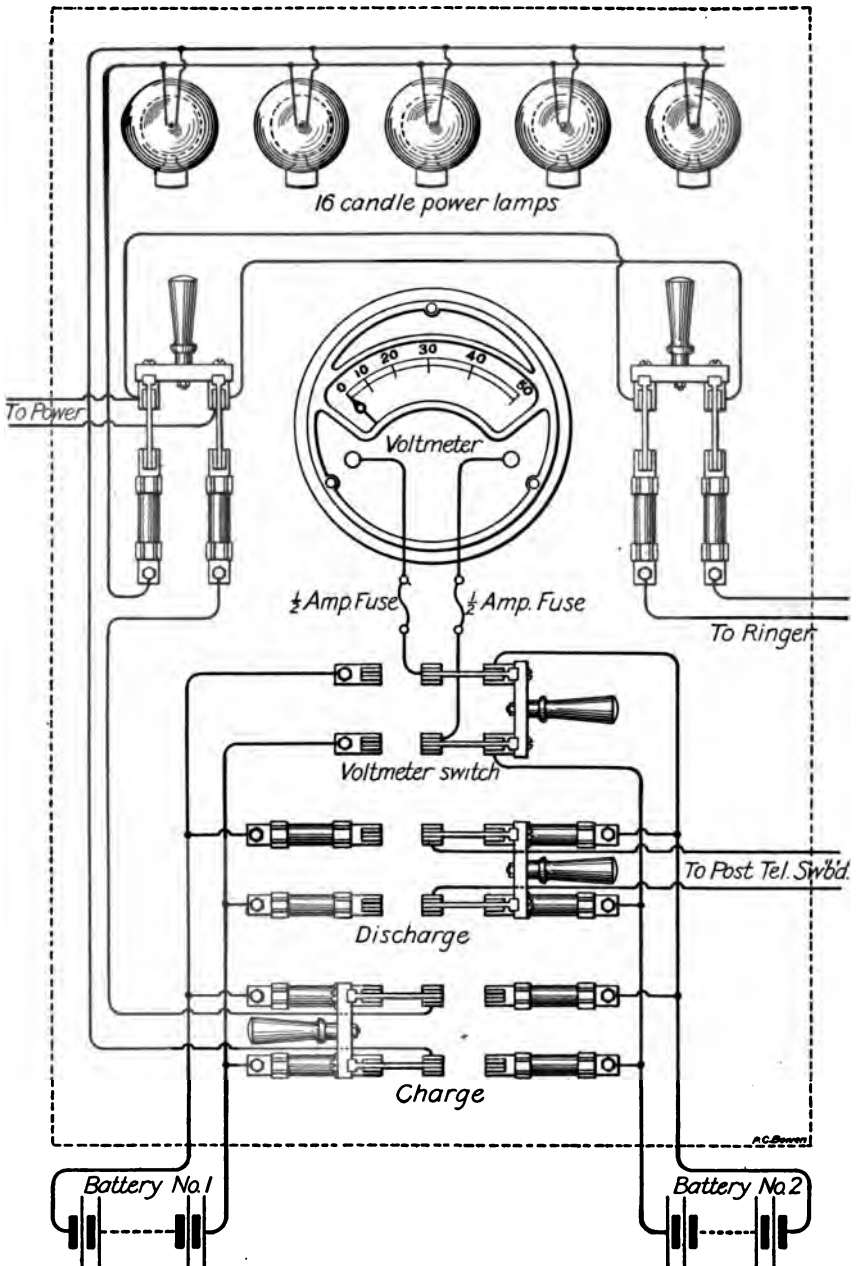

FIG. 18.—Charging panel for small storage battery for post telephone installations.

The circuit and details of the power switchboard controlling these batteries and machines will be found in Manual No. 8.

TESTS FOR PURITY OF ELECTROLYTE.

The necessity for using pure electrolyte in storage batteries is something which is seldom recognized. Its importance in maintaining a battery in its highest efficiency for any length of time is a matter which should receive attention, not only at the time the battery is set up, but subsequently in the addition of water or fresh electrolyte.

The most frequent impurities in water are sodium or magnesium chloride, and some of the salts of lime and iron. The presence of lime will, of course, be objectionable, but its presence in very small quantities is less objectionable than that of the other impurities.

In general, it may be stated that the only suitable water for safety is distilled water, and no amount of trouble necessary to get this kind of water should be considered as too great when making up the electrolyte if strong acid be furnished, or for subsequent additions to replace loss by evaporation.

If strong acid is furnished, the method of mixing this with the requisite amount of water to bring the specific gravity of the solution to 1.210 has already been stated. It is again urged that no acid be used which is made from iron pyrites; the only suitable electrolyte is made from acid which is manufactured from pure sulphur.

The impurities which may be in the acid, and for which tests should be made, are: Chlorides or free chlorine, the salts of iron, copper, mercury, and the nitrates. Small cases of reagents will be furnished by the Signal Corps for storage-battery installations where there are 15 cells and upward, and tests should invariably be made before setting up the battery and in subsequent additions of electrolyte.

It must be noted that after running some time the electrolyte may become contaminated with chlorides or nitrates from the plates, formed during manufacture. It should be noted that traces of objectionable elements will probably be found in even new electrolyte and almost in every case in old electrolyte that has been used in batteries. It is only when found in excessive quantities that these are prohibitive. However, if uncertainty prevails regarding the character of an electrolyte, a sample should be sent in for analysis. An eighth-ounce bottle, thoroughly cleaned, should be sent to the Chief Signal Officer and a report obtained.

The small reagent case will contain the following chemicals:

- Nitrate of silver.
- Red prussiate of potassium.
- Yellow prussiate of potassium.
- Strong ammonia.
- Iodide of potassium.
- Concentrated sulphuric acid.
- Diphenylamine.

If distilled water is used, of course no tests of it will be necessary, but any natural water should be open to suspicion.

Tests for chlorine or chlorides.—A few drops of solution of nitrate of silver in a test tube partly filled with electrolyte will give a curdy, white precipitate of silver chloride if chlorine or its salts are present. This chloride turns to a violet tint on exposure to light. If the clear liquid be poured off this white precipitate and strong ammonia be poured on it, it will dissolve.

Test for iron.—The presence of ferrous salts in the electrolyte is shown if a dark-blue precipitate is given upon the addition of a solution of the red prussiate of potassium. If ferric salts are present in the electrolyte, a solution of yellow prussiate of potassium will give a blue tint. Consequently, if into two test tubes, one of which contains a few drops of yellow prussiate and the other a few drops of red prussiate, a little electrolyte be poured, the two tests can be made at once. If the impurities be present in small quantities there will not be a precipitate formed, but a bluish-green coloration will result.

Test for copper.—Place a small quantity of electrolyte in a test tube and add an excess of strong ammonia. If copper be present there will be a bright bluish tint given to the mixture. If present in large quantities, a chocolate-colored preparation will be formed upon the addition of solution of the yellow prussiate of potassium.

Test for mercury.—The mercurous salts will give an olive-green precipitate with iodide of potassium; the mercuric salts, a scarlet precipitate with the same reagent.

The use of hydrometers having mercury in the lower bulb will frequently give a mercury impurity in the electrolyte through breakage of this bulb. Consequently it is better to use only a shot-filled hydrometer.

Test for nitrates.—Some diphenylamine should be dissolved in a small quantity of concentrated, chemically pure sulphuric acid and put in a test tube. A small quantity of electrolyte is then carefully dropped in the same tube. If a blue color results, nitrates or nitrites are present. Traces of nitrates are very objectionable. They cause a surprisingly rapid deterioration of the plates.

Reports and records.—The proper maintenance of a storage battery requires that tests and readings be taken on them at regular intervals. To that end the Signal Corps requires certain reports covering the storage batteries installed for fire-control installations and the post-telephone systems of coast artillery posts.

A semiannual report is required, showing the condition of the cells at time of the report, number of times charged and discharged, the voltages of cells, specific gravity, amperage of last charge, and tests of electrolyte.

Form 263 is provided for submitting this report.

A storage-battery record book is provided in every fire-control switchboard room for recording the readings necessary for the operation and maintenance of the batteries. Data showing daily specific gravity and temperature readings, weekly end-cell voltage readings, and information regarding the pilot cell and any special work done on each cell, shown by weekly inspection, and the specific gravity and voltage for each cell immediately after each charge.

No records or reports are required from interior posts, but it is recommended that for each storage-battery installation a set of rec-



FIG. 19.—“Duro” battery used for field service.

ords be maintained, showing the information which the instructions in this chapter have indicated are necessary for proper maintenance and operation.

“DURO” PORTABLE STORAGE BATTERIES, FOR USE WITH WIRELESS PACK SETS, U. S. SIGNAL CORPS.

For use with field wireless pack sets the Signal Corps is now furnishing the “Duro” portable storage battery. These batteries come in sets of four cells each, of 20 and 60 ampere capacity, rated on

1 ampere discharge rate. The jars for these cells are made of hard rubber, so constructed as to meet the requirements of a portable battery. The four cells comprising the battery are encased in a case of solid cold rolled and tinned copper, which is lead-lined around the top to a point $2\frac{1}{2}$ inches below the same, and has a steel bottom. Between the jars and the case is an insulating wall of semi-soft wax to act as a protecting cushion. A carrying handle of strong 3-ply rubber belting is provided. The plates are of the Faure or pasted type and are made upon the same principle as those for stationary batteries. Instead of ordinary liquid acid electrolyte there is used a solid or semi-dry gelatin electrolyte, which makes the battery portable. It is necessarily cleaner and requires less attention than the liquid battery used in the same manner. The covers of the jars are sealed up tightly with a compound of asphaltum wax to prevent any possible leakage.

These batteries are made up in two sizes, 20 and 60 ampere hours. The 20-ampere hour cell is usually provided for the wireless pack set.

The following instructions for the operation and maintenance of this type of storage battery should be closely followed:

When in use the "Duro" battery should always be carried in a vertical position, with all plugs tight to prevent entrance of dirt. The battery should be given a thorough discharge at a normal rate every six weeks and then immediately fully recharged. The batteries can be charged through lamps in the usual manner, previously described in this chapter. If the battery is not used, it should be given a discharge every six weeks and recharged as described above. The case and terminals should be covered with vaseline after the set is wiped dry with a rag.

Testing.—The condition of the battery is best indicated by the voltmeter in the usual manner. The normal voltage when fully charged is the same as that for other types of lead battery, and this battery should be considered completely discharged when the voltage of the individual cells reaches 1.8 volts.

As previously stated, the voltage should be read on close circuit and not while the battery is on open circuit. The battery should never be allowed to stand in a discharged condition. When it reaches the minimum voltage it should be immediately recharged. The polarity terminals of the battery are indicated, and care should be taken that they are correctly connected when the cells are recharged. The charging rate for a "Duro" 20-ampere battery is at a maximum of 2 amperes, and for the 60-ampere battery a maximum of 3 amperes. In cases of emergency a maximum of $2\frac{1}{2}$ amperes for the 20 and 4 amperes for the 60 ampere hour cells is possible, but this is not advisable, as the company states that this is very severe on the life of the battery.

It will take approximately eight hours to recharge the 20 and twenty-one hours to recharge the 60-ampere battery, if the battery is originally completely discharged. When the charge is completed or batteries taken off for use, see that all surplus liquid is taken off from the vents by means of a syringe, the battery wiped dry, and tightly corked for use. If the battery is left to stand for some time, it is good policy to leave the liquid in the vents, drawing it off only when putting in use again. This surplus electrolyte does no harm when left in the battery, except that it does not make it clean and dry to use.

The following is a summary of the points which must be observed in the operation and maintenance of the "Duro" storage battery:

1. Always carry in a vertical position.
2. Battery should have a thorough discharge every six weeks.
3. Vents should always be kept tight when in use.
4. When charging, open vents, add enough pure water to bring level halfway up to hole. Leave out corks while charging and replace when charge is completed.

CHAPTER III.

THE MORSE TELEGRAPH.

The two methods of arranging the ordinary Morse circuits are called the "open" and "closed" circuit systems.

The latter is frequently called the American system, the diagram of which is given in figure 21. In this only one line battery is necessary, although in practice it is found better to divide the battery between the terminal stations as shown, care being taken not to connect the batteries in opposition. Each key is furnished with a circuit-closer lever, and when the line is quiet the current is constantly running, keeping the relays and sounders closed. When any station opens his

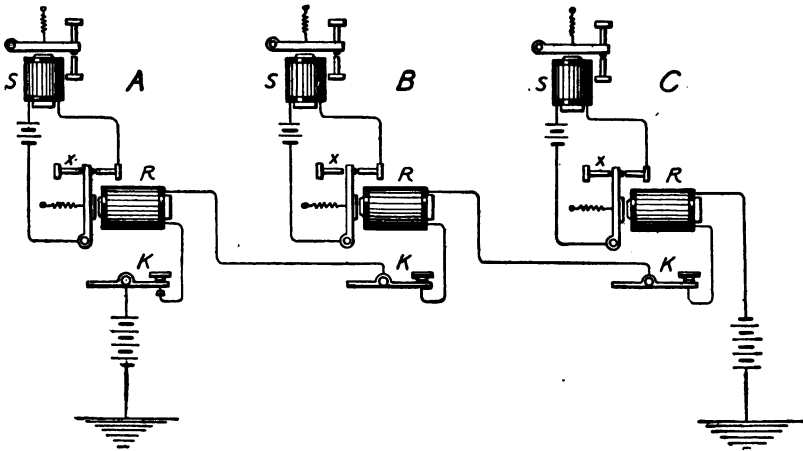

FIG. 21.

circuit by means of the lever, he controls it entirely with the key. This system is in universal use in the United States and Canada.

The diagram of the open-circuit system is given in figure 22. In this system each station must have sufficient main-line battery to work the line. The keys have a front and a back contact. (See fig. 25.) When the line is quiet, there is no current running, and when any station depresses his key he breaks the back contact and introduces his main-line battery through the front contact, operating the relays on the line. The relay is frequently put in the back-contact circuit, in which case the operator does not work his own relay, thus cutting

its resistance out of the circuit, but the American operator prefers to hear his own instrument work.

This system has been used exclusively on the short signal-corps submarine cables. It obviates the constant application of battery to the cable, as would result from use of the closed-circuit system.

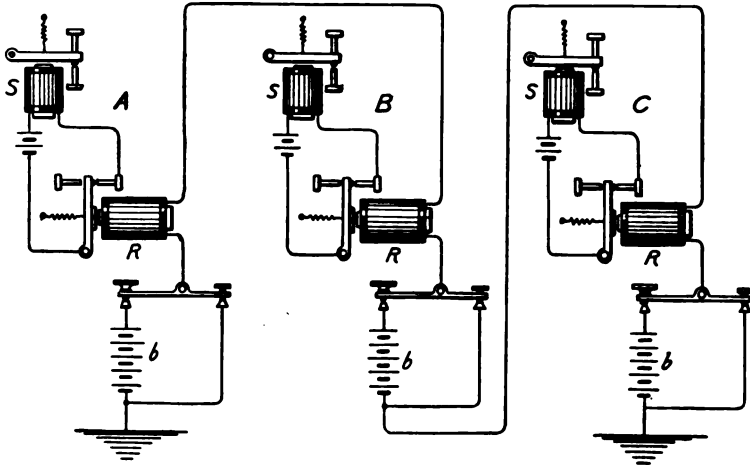

FIG. 22.

TELEGRAPH-OFFICE EQUIPMENTS.

The familiar essential instruments of the ordinary Morse telegraph office need but brief mention, as it is assumed that the reader is already familiar with the first principles of telegraphy.

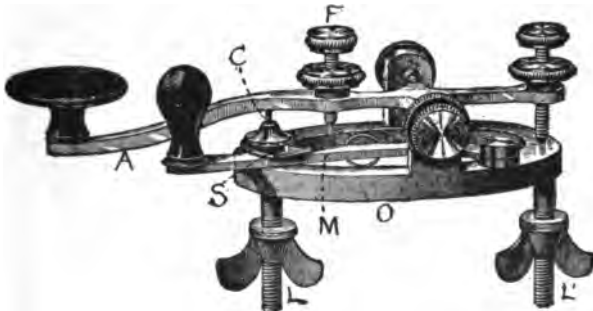

FIG. 23.

THE KEY.

The ordinary American Morse or closed-circuit key is shown in figure 23. The lever *A* is ordinarily of steel nickel plated; the milled-head screw *F* adjusts the tension of the spring below it. *O* is the base which supports the trunnion bearings of the key. *M* is the circuit-closer lever, which is pivoted at the rear and slips under a

curved metal piece, *S*, which is insulated from the base, but in connection with the front leg *L*. This front leg is connected with the relay and the back leg *L* to the battery or other line if it is a "way" office. *C* represents the upper and lower contact points of platinum, this metal resisting the corroding action of the spark produced on opening the key.

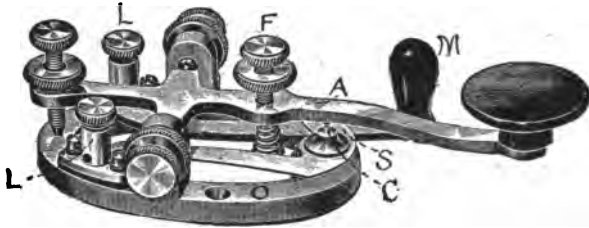

FIG. 24.

The legless key is shown in figure 24. The binding posts instead of the legs are connected to line and battery, respectively. The parts corresponding to the leg key are similarly lettered.

The "open-circuit" key has an insulated front and an insulated back contact, and the circuit-closing lever is dispensed with. As shown in figure 25, the screw *C* on the base of the key is connected with the relay, the insulated lower front contact, *D*, with the battery,

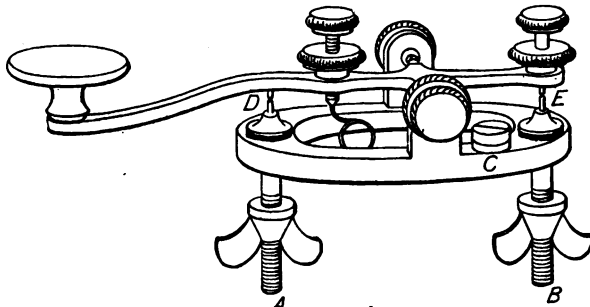

FIG. 25.

and the insulated back contact, *E*, with the ground at a terminal station or with the outgoing wire at a "way" station.

THE RELAY.

The function of the relay is, briefly, to cause a comparatively powerful local current through a sounder to be controlled by a much feebler one in the main-line circuit. The relay coils are included in the main-line circuit, the two binding posts on the right (fig. 26) being connected with the key and line, respectively, the binding posts

on the left being connected with the sounder and local battery, respectively. The main and local circuits are indicated by the

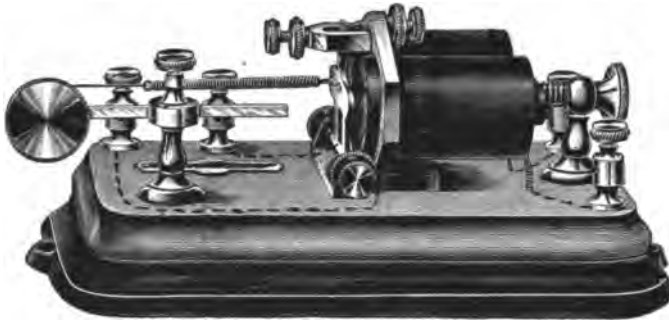

FIG. 26.

broken lines. The resistance of the relay coils is now almost universally 150 ohms, although on some short lines a "pony" relay of 20 ohms is used.

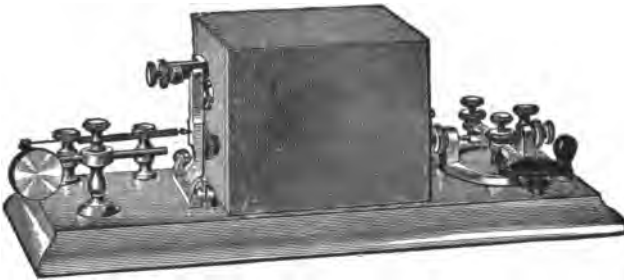

FIG. 27.

The box relay with the key on the base is shown in figure 27. This relay has a heavier lever for giving a louder sound than that of the ordinary relay, the resonance of the box assisting. As it may be used

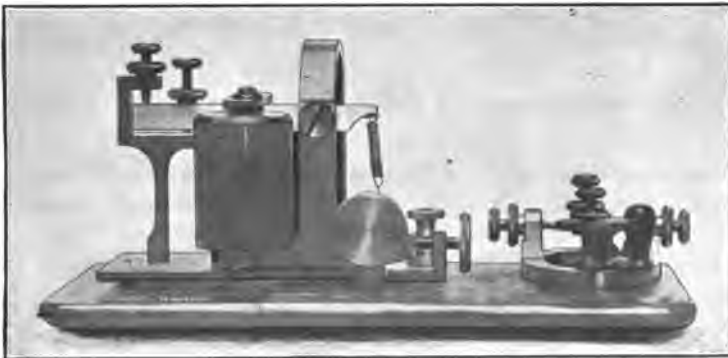

FIG. 28.

at temporary field offices, when local batteries are not obtainable, and is of great strength and simplicity, it is a most useful instrument for military lines.

The "main-line sounder" (fig. 29) is somewhat of an improvement on the box relay. The coils are usually wound to 150 ohms, the same as other main-line instruments.

The "pocket relay" is a compact form of main-line sounder for testing purposes. About 40 milliamperes current is required to operate the 150-ohm instrument to best advantage.

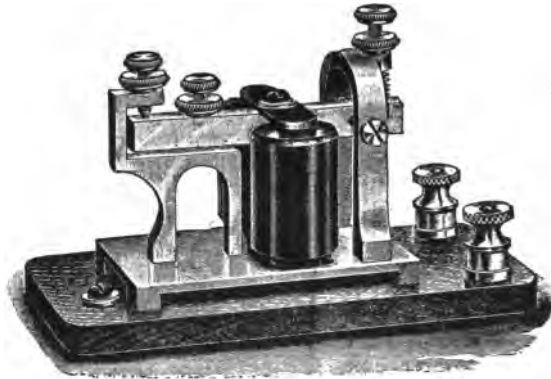

FIG. 29.

THE SOUNDER.

This well-known instrument is shown in figure 29, this being one of the most common forms now in use. Its connection with the relay and local battery circuit has already been

indicated. The coils are usually wound to a resistance of 4 ohms, and it requires about one-fourth ampere to operate the sounder as vigorously as is required for ordinary offices. Hence two bluestone cells, each having about 1 volt E M F and 2 ohms internal resistance, will give the required current.

$$\left(C = \frac{E}{R}; .25 = \frac{2}{2 \times 2 + 4}\right)$$

If the sounder is put in circuit with a cell of higher E M F and lower resistance, some resistance wire should be put in to keep the current down to one-fourth ampere; otherwise the battery will be used up wastefully. For example, with a Fuller cell of 1.8 volts

E M F and one-fourth ohm internal resistance, $C = \frac{1.8}{\frac{1}{4} + 4} = .42$ ampere,

which is considerably more current than necessary. The necessary added resistance, X , can be found as follows: Required current is .25

ampere, so $.25 = \frac{1.8}{4 + \frac{1}{4} + X}$; $1.06 + .25 X = 1.8$; $X = 3$ ohms, the "dead resistance" to be introduced in circuit.

In cases when a number of sounders are fed from one storage cell, a "dead resistance" of 4 ohms should be inserted in each sounder circuit, as the storage cell has virtually no internal resistance and an E M F of 2 volts.

SWITCHBOARDS.

These are either terminal or intermediate in their use, and as there is considerable difference in extent and character of the wiring, they will be considered separately.

The intermediate or way-station switchboard is represented in simplest form in figure 30. Suppose two lines coming into a station are brought to the tops of the vertical strips of brass, as shown, usually through lightning arresters. These latter are frequently strips or disks of brass connected with the ground and placed close to the strips connected with the line. Between these vertical strips of brass are vertical rows of brass disks, all the disks in any horizontal row being connected together by a metal strip on the back of the board. Semicircular spaces are cut adjoining each other in the strips and disks, so connections may be made at any of these points between the disks

and strips by the insertion of conical metal plugs with hard-rubber heads. By means of these, sets of instruments may be connected up with each other, the different lines, or the ground; as shown. To cut out a set of instruments, insert plugs at 21 or 22. To cut in the upper set on line No. 1,

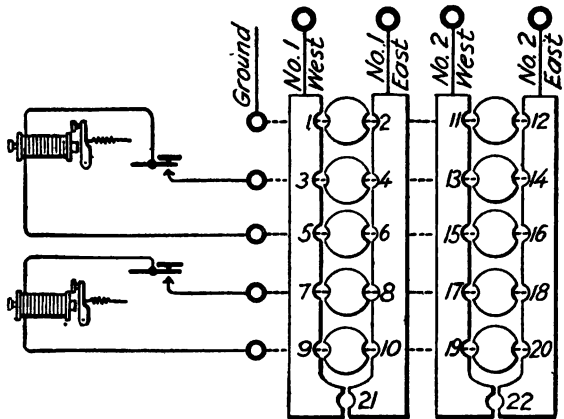

FIG. 30.

take plug out of 21 and insert plugs at 4 and 5 or 3 and 6. To cut upper set in on line No. 2, remove plugs from 3, 4, 5, 6, and 22 and insert them at 13 and 16 or at 14 and 15. In a similar manner the lower set of office instruments may be cut in on either line.

Suppose either of the sets is cut in on No. 1. If to test we wish to ground No. 1 east, we insert a plug at 2. The closing of the circuit, if open before, will show at once that the line is open east of us. In like manner test by grounding west may be made on either wire. The foregoing illustrates the use of the ground wire.

Due to defects in one of the lines, the main office may desire a "patch" made. This means that it is desired to cross-connect lines 1 and 2. Suppose the chief operator directs that line No. 1 west be connected with line No. 2 east. Of course it is desired to keep one of the sets cut in at this office on this patched line.

Plugs are inserted at 3 and 16 and all other plugs are removed.

To patch No. 1 east with No. 2 west, put plugs at 4 and 15.

To loop No. 1 west with No. 2 west, put plugs at 3 and 15, if desired to leave instruments in. If desired to leave them out, insert plug at 13 instead of at 15.

If directed to ground this loop, as may be needed sometimes in testing, insert a plug at either 1 or 11.

The simplest form of office switch, called a plug cut-out, is shown in figure 31. The line wires come in from above, the wires to instruments come out below, and the upper central wire leads to ground. The insertion of the plug in the upper holes grounds "east" or "west," and when in the lower hole cuts out the station. The central ground plate near the line strips acts as a lightning arrester.

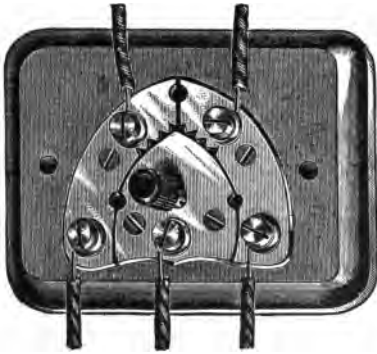

FIG. 31.

LIGHTNING ARRESTERS.

The principle in general upon which these are made is to bring the line or some of the first metal parts to which it is connected in the office close to a conductor connected directly to the ground. The lightning jumps to this ground connection instead of going through the instruments. These arresters are

frequently parts of the switchboard, consisting of a metal plate connected to the ground, extending across the vertical line straps and not quite touching them, or of a series of brass disks extending closely over the straps, the disks being all connected to the ground wire. A simple form of arrester is shown in figure 31, being part of the plug cut-out.

The Mason lightning arrester of figure 32 is much used in signal-corps work. It comprises a porcelain base *B* on which are mounted two line-binding posts *L L*₁ connected to two mica fuses *F F*₁. These fuses connect with choke coils *C C*₁, which end in binding posts *T T*₁. The line wires are connected to the binding posts *L L*₁ and instrument-binding posts *T T*₁. The coils *C C*₁ are wound around carbon cores *E* and are insulated therefrom by mica plates *M*. These mica plates do not completely inclose the carbon block, but leave a small air gap in the corners of the carbon. The carbons are connected to the binding posts *C*, which in turn is connected to ground. The theory of the action of these coils is that a high frequency oscillatory current such as lightning coming in on the line will find a path from the corners of the coil to the carbon core of less resistance than through the coil to instrument. This discharge takes place at the

corners, due to the fact that the tendency for the discharge to leave the wire is greater at these points and that there is an air gap between the mica plates. While these coils are a protection against high frequency current, they are not affected by continuous or low frequency current. It is also found that in the case of high potential discharge a low resistance circuit is set up to ground, which causes an abnormal current to flow through the arrester. To provide against these abnormal currents a form of fuse is usually installed in connection with the outside gap *F*. These fuses are provided with a fine wire for carrying current mounted on a mica strip in the case of the Mason arrester. This wire is burnt off by excessive current on thus

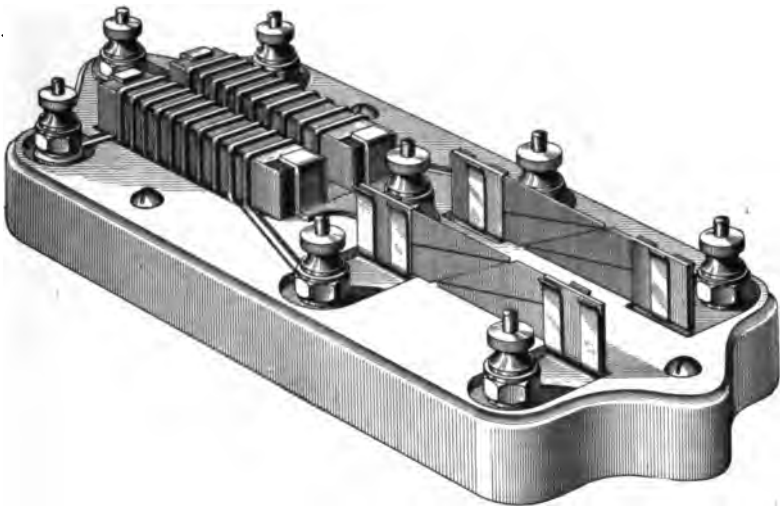

FIG. 32.—Mason lightning arrester with Z link fuse.

opening the circuit. It will be seen from this that the line should invariably be connected to the fuse side of the arrester.

TERMINAL OFFICE SWITCHBOARD AND BATTERY ARRANGEMENTS.

The general plan of the terminal switchboard is shown in figure 33, introducing a row of spring jacks at the bottom of the board. The method of utilizing these in cutting in sets of instruments by insertion of the double flat plugs is shown. These flat plugs, with hard-rubber insulation between the metal strips composing them, are connected with flexible insulated double-conducting cords leading to the sets of instruments. It will be seen that each line comes in through a fuse wire to the top spring contact of the jack, and, if no plug is inserted passes through the back contact and up to one of the vertical straps of the board. The insertion of a round conical plug at the appropriate

disk connects it to the battery and ground. The insertion of a flat plug and cord leading to a set will introduce that instrument into the circuit. The various arrangements for interconnecting, the provision for duplex and repeater sets, and the connections for loop switches can be studied out, especially if the reader will consult Maver's American Telegraphy and Jones's Pocket Edition of Diagrams, etc., both of which have been consulted in preparing the diagrams and above descriptions.

As most modern terminal and repeating offices are now provided with storage battery and dynamo sources of current, the method of supplying the terminal switchboard and its connecting lines will be described in the general scheme outlined in figure 34.

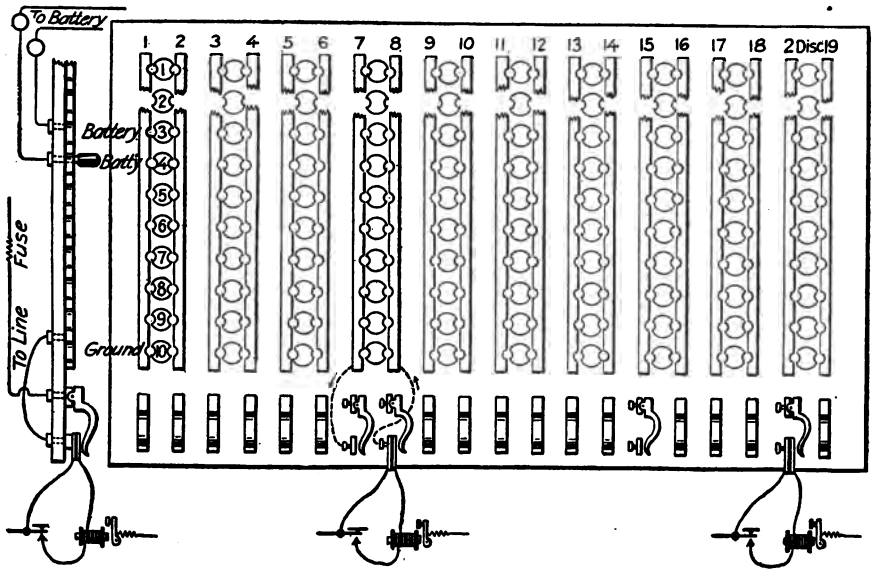

FIG. 33.

With the wire *E F* disconnected and the + and - mains connected, as shown in the dotted lines, the cells are connected to the dynamo in two rows in parallel for charging. When completely charged they are disconnected at *C* and *D* and reconnected by *E F*. This puts the 60 cells in series again with the negative end to ground. At various points (10, 20, 30, etc.) taps are taken off, through incandescent lamps introduced as safety resistances, to various horizontal rows of disks on the switchboard. Thus, beginning at the top, this row of disks is at the highest potential (120), and a conical plug inserted, connecting any disk of this row with the line leading to the vertical strap through the jack at the bottom, will give the strongest current, and so on down the rows to 10, which brings into the circuit only the last 5 cells next to the grounded end of the battery. The

low internal resistance of the storage battery permits feeding almost any number of lines out of the same row of cells without interference. The introduction of lamp resistances is necessary because of this low internal resistance of the cells, as a grounding of the line close to the terminal office would otherwise cause a current dangerous to the instruments. The amount of lamp resistance to be inserted at each potential is, according to Jones, in his Pocket Edition of Diagrams, etc., 2 ohms for each volt. One ordinary 16-candlepower lamp

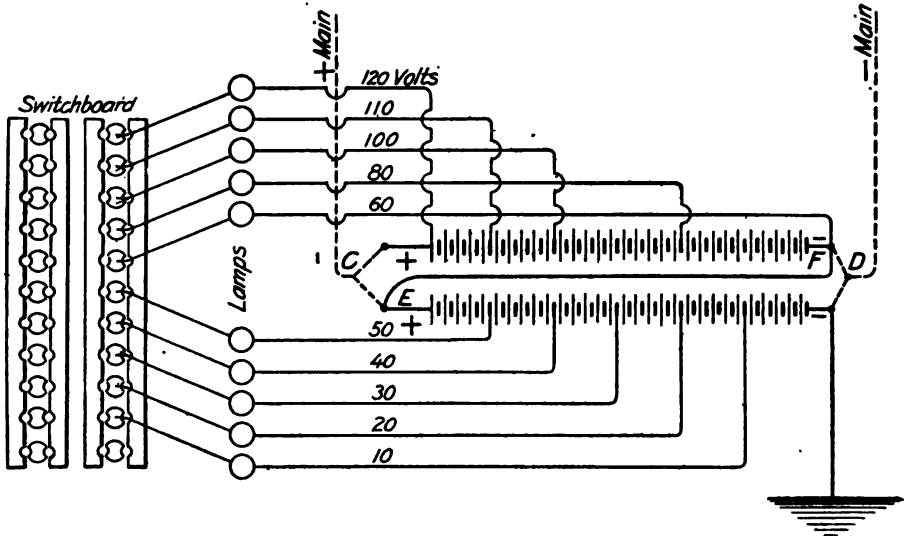

FIG. 34.

would be about right for the 110-volt potential, and two of these in parallel for the 50-volt potential.

TELEGRAPH REPEATERS.^a

THE MILLIKEN REPEATER.

This was one of the earliest repeaters introduced into the telegraph service, and it is still a standard repeater of the principal telegraph companies of this country.

This repeater may perhaps be termed an automatic electro-mechanical repeater, for, while electricity is the controlling force in the performance of its automatic functions, the ultimate action is mechanical, as will be seen.

Figure 35 is a theoretical diagram of the connections of the Milliken repeater. *R* and *R'* are the main-line relays. *EM* and *EM'* are extra magnets, which, in practice, are supported on metal standards

^a The descriptions and diagrams of the Milliken and Weiny-Phillips repeaters are taken by permission from Maver's American Telegraphy.

that hold them rigidly in their respective positions relative to the main-line relays. The armature levers of the extra relays are pivoted at the top as shown. T and T' are transmitters. The levers L L' of the transmitters are insulated from the tongues α α' at points i i' and from screw posts F F' by small pieces of hard rubber.

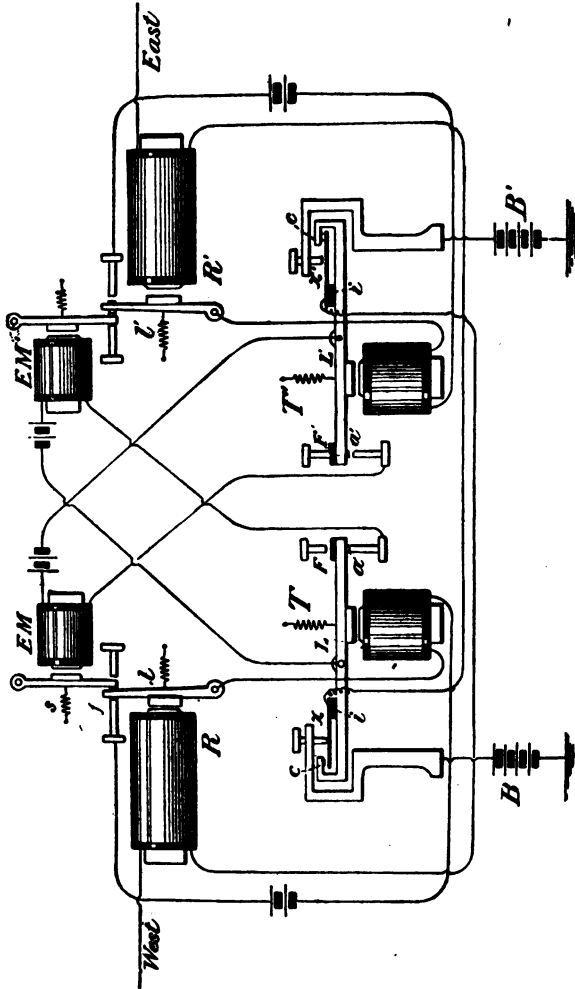

FIG. 35.—The Milliken repeater

The working of this repeater may perhaps be best described by assuming that the east is about to send. To that end he opens his key; that opens relay R' and its lever l' falls back, as in the figure, and opens the local circuit controlling the transmitter T' . As the latter instrument opens, it first breaks the local circuit of EM at a' ; the retractile spring S of extra magnet EM at once pulls its lever against the lever l of relay R as in figure; presently the transmitter T' opens

the western circuit at x' ; this demagnetizes relay R , and its spring would withdraw its lever l from its front stop f , thereby opening the transmitter T , and consequently the eastern circuit at x , but that, as already said, the lever of EM is against lever l , holding it on its front stop, and thus keeping the local circuit of T closed. When the east again closes his key, relay R' also closes; consequently so does T' . This action closes EM , and the lever of that instrument is withdrawn from its position against the lever R . This releases R 's lever, but, as now the western circuit is closed at x' , the lever l is held forward by its armature.

In this way the function of the repeater in keeping closed the opposite transmitter, and virtually also the circuit which is being "repeated" into, is performed.

Should the west now desire to "break" or send to the east, he opens his key, which action, by opening the local circuit of transmitter T at F , opens the eastern circuit at x . The east, finding his circuit now open, closes his key to await the remarks of the west, when the "repeating" actions just described are reversed.

THE WEINY-PHILLIPS REPEATER.

This repeater, which is in operation on the lines of the United Press, the Postal Telegraph Company, and elsewhere, is shown in figure 36. The opposite transmitter is kept closed at the repeating station by the action of an extra magnet added to the main line relays, the construction and operation of which is, briefly, as follows: The extra magnet is wound, as shown, with two coils, through which a current flows from a local battery in opposite directions around the core, so that the latter is, normally, not magnetized. When, however, one of these extra coils is opened the current in the other coil magnetizes the core. The wire which is joined to both coils of the extra magnet goes directly to the right-hand end of the opposite local battery. The other end of each coil passes to the other pole of the same battery, one coil by way of the left-hand post and the other by way of the lever of the opposite transmitter, as shown. This lever is insulated from the left-hand post when the transmitter is open. Consequently, when the left-hand transmitter is open, as in figure, the circuit of the left-hand coil of the extra magnet of the eastern relay is open at the left-hand post of the western transmitter, and as a result thereof that extra magnet is magnetized by the current passing through the right-hand coil, and hence the armature lever of that relay is held against its front stop. Thus, for example, when, as in the figure, the west sends to the east, and thereby opens his key, the western relay in the repeating office opens and its armature lever falls back, opening the local circuit of the western transmitter. As this

transmitter opens it first breaks, at its left-hand post, the circuit of the left-hand coil of the extra magnet of the eastern relay, and next opens the eastern main line circuit at the right-hand post. As, however, the armature of the eastern relay is kept closed in the manner stated by its extra magnet, the eastern circuit remains unbroken in the repeating station.

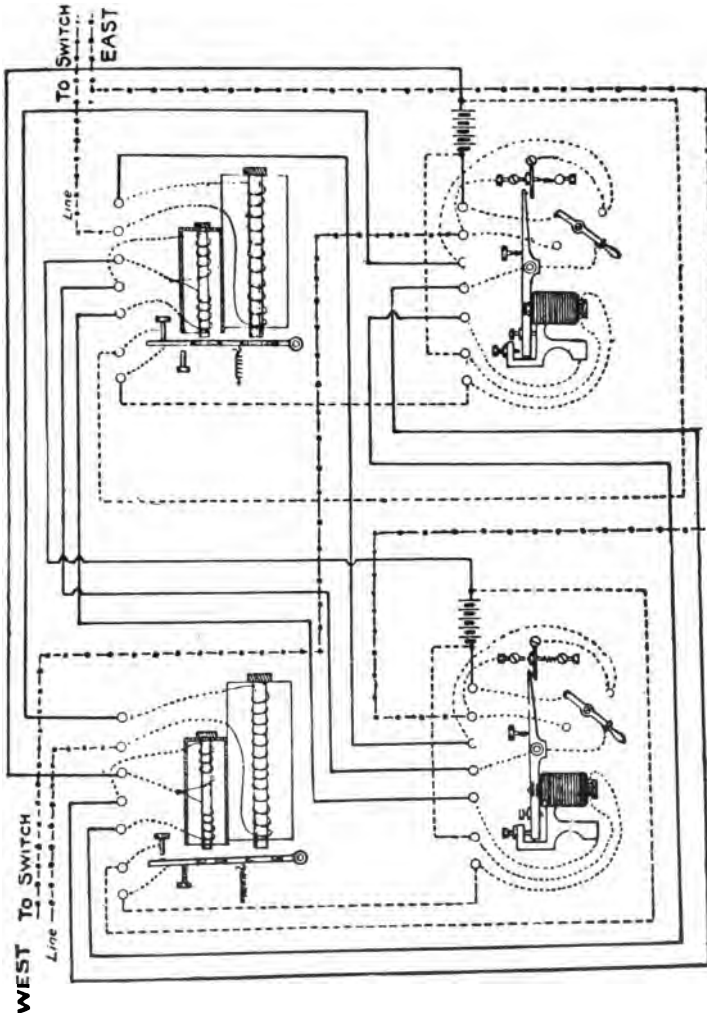

FIG. 36.—The Weiny-Phillips repeater.

The local battery, it will be seen, is also utilized to operate its respective transmitter. A button switch is placed on the base of each transmitter for the purpose of short-circuiting the main line contact points on the transmitter when it is desired to use the transmitter simply as a sounder for the relay.

DUPLIX TELEGRAPHY.^a

By duplex telegraphy is meant the sending of two messages over one wire in opposite directions, that is, one from each end of the wire, simultaneously.

In ordinary Morse, or single-wire working, signals can only be transmitted by one station at any one time, because the opening of any one of the keys operates all the instruments on the circuit.

To make duplex telegraphy possible, therefore, it is essential that the signals transmitted from the home station shall not interfere with the signals to be received at the home station. The home receiving instruments at each station must consequently be so constructed or so placed that while ready to respond to signals from the distant station they will not respond to signals transmitted from the home end.

These requirements are met in several ways, but the two most important are known as the "differential" and the "bridge" methods.

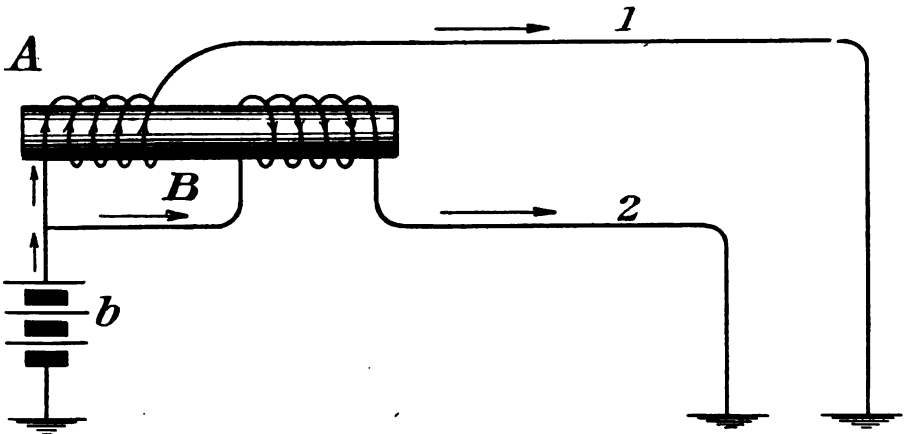

FIG. 37.

In figure 37 *B* is a bar of soft iron, around which are wound two similar coils of insulated wire which respectively start from a common battery *b*, and are continued by wires 1 and 2 to the earth. Since the current generated at *b* has a choice of paths to complete its circuit, it divides in proportion to the resistance of each path. In figure 37 the coils are wound around *b* in opposite directions. The resistance of each wire, 1 and 2, attached to the coils, is the same, hence an equal amount of current flows through each coil from battery to earth. Consequently the current in coil 1 has a tendency to make one end of the bar a north pole, while the current in coil 2, being in the opposite direction around the bar, has an equal tendency to make the same end a south pole. Hence the bar is not magnetized by either

^a From Maver's "American Telegraphy," by permission.

coil, as the magnetizing effect of the one is neutralized by the equal and opposite magnetizing effect of the other.

Since, then, with equal currents flowing in these coils in opposite directions, no magnetic effect is produced in the bar, it is clear that it is immaterial whether the current from b be flowing or not so far as the bar is concerned.

A bar of soft iron, or a relay, wound in the manner stated is said to be wound "differentially," not because of the opposite winding, but because they are operated, that is, magnetized, by differences in current strength in the respective coils.

Suppose now that the bar B , in figure 38, represents a home relay of a duplex telegraph system, and that bar B' is the core of a distant relay, with but one coil shown. In order that equal currents from the battery at the home station shall still pass through the coils of B ,

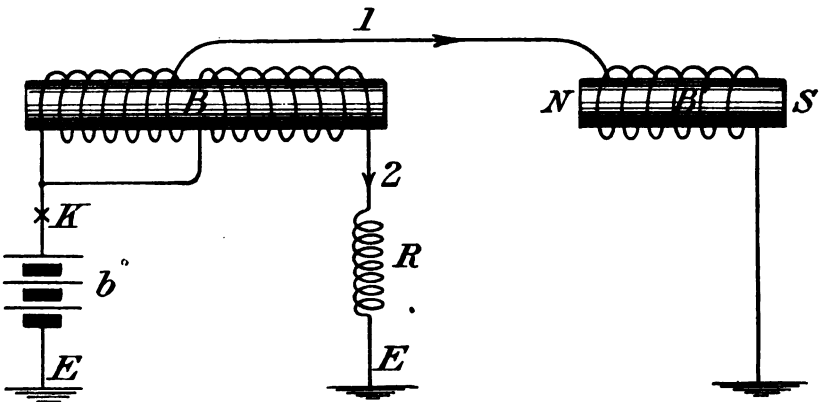

FIG. 38.

a coil of wire R , equal in resistance to the line wire between B and B' is placed in wire 2. The result is that, owing to the winding of its coils, B , at A , is not magnetized by the current from the battery at A , but as the current from that battery passes in one direction only around B' that bar is magnetized. If, now, a key were placed in the circuit at K , and it should be opened and closed, the bar B would remain unaffected, as before, but B' would be magnetized and demagnetized, as in the case of a relay in an ordinary Morse single circuit.

If, then, differentially wound relays be placed at both ends of the wire, with a battery, key, and resistance coils at both stations, it will be found that neither of the relays will be responsive to its home battery, but that each will respond to the movements of the distant key, or transmitter, in a manner which may be understood by the aid of the following figures.

In figure 39 *B* is an iron bar which may correspond to a duplex relay at *A*. *b'* is a battery at a distant station in circuit 1. The resistance of wires 1 and 2 are supposed to be equal. Battery *b'* is so arranged that its current coincides in direction with the current from battery *b*. It is assumed that the electromotive force of each battery is the same. The effect is that, the electromotive force in wire 1 being doubled, the current in wire 1, and, consequently, in coil 1, of the home relay, is doubled, while, as the electromotive force in wire 2 has not been increased, the current in coil 2 remains as in figure 38. This "excess" of current in coil 1 magnetizes the bar virtually as if there were but one coil with a current from one of the batteries flowing in it.

Should the battery at the distant end be so connected that its electromotive force opposed that at *A*, the result will be that no current will flow in wire 1; but, as there is no opposing electromotive force at the distant terminal of wire 2, a current will flow through coil 2

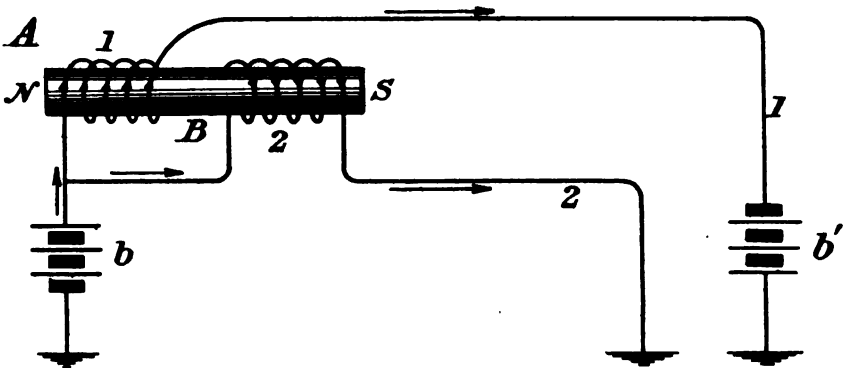

FIG. 39.

and wire 2 from the battery at *A*, and this will magnetize the core of the relay. From which it is seen that it is, in a sense, immaterial whether the batteries at the ends of the wire 1 assist or oppose each other. In either case the operation of home relay will be due to the operation of the distant key.

The main feature of the differential method just described is that it prevents the home battery from affecting the home relays, by securing, so far as the home battery is concerned, an equal flow of current through each coil in opposite directions around the core, but yet leaves those relays free to be actuated by the distant battery, which latter is, of course, essential.

There is, as already noted, another method employed for the same purpose, namely, the "bridge" method which depends for its success in preventing the effect of home battery upon the home relay upon the maintenance of an equal and opposite potential, or pressure, at the terminals of the bridge wire in which the relay is placed. This

method, which will now be described, is founded on the principle of the Wheatstone bridge.

“Bridge” method.—In figure 40 wires 1 and 2 and battery remain as before. The coil around the bar *B*, representing the relay, is now shown connected between wires 1 and 2. In this arrangement but one coil is necessary in the relay. *a'* and *b'* are resistance coils placed in the “arms” of the Wheatstone bridge. Assuming the resistance (fig. 40) of these arms to be equal, and the wires 1 and 2 also equal, the electric pressure or potential, due to battery *b*, at the terminals of the bridge wire must be equal and opposite, consequently a current will, of course, not flow through the bridge wire, and hence the bar *B*, or relay, as in practice it would be, is not magnetized.

If a battery be placed in the circuit at the distant end of wire 1 it will cause the potential, or pressure, to vary so that a difference of potentials is brought about at the terminals of the bridge wire and a

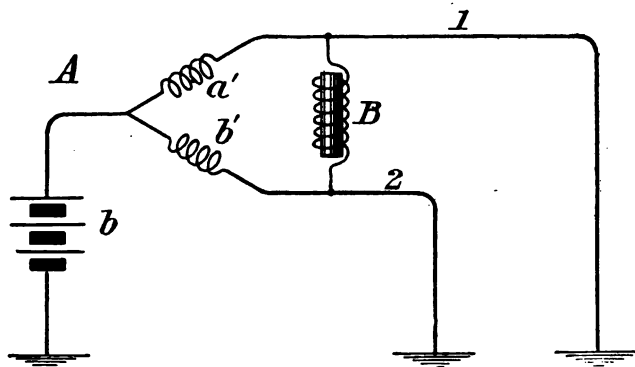

FIG. 40.

current will flow from the terminal of higher to the terminal of lower pressure.

If then (as in the case of the “differential” method) each end of a duplex circuit be equipped with the bridge arrangement, etc., it is clear that the variation of pressure at the terminals of the bridge wire, due to the operation of the distant keys, will effect an analogous result to that of the excess of current in one of the coils in the differential arrangement of the coils of the relays, namely, a current will flow in the coil and the core will be magnetized.

In the single Morse system, as stated, when any one key is open it opens the entire circuit; consequently, during that time, no other key can “operate” the circuit. It is clear that such a result following opening of one of the keys in a duplex telegraph system would be fatal to success. This result is avoided in duplex telegraphy by the use of keys, or transmitters, of peculiar construction, which will be described later on.

There are two systems of duplex telegraphy quite generally used in this country, namely, the Stearns duplex and the polar duplex.

The Stearns duplex system is operated by "increase" and "decrease" of current on the line, or by placing the line to ground and to the battery, alternately.

The polar duplex is operated by "reversals of polarity," obtained by alternately placing first one pole and then the other of a battery, or other source of electricity, to the line.

In the operation of these systems, as will be noted in the ensuing description, distinctly different apparatus is employed. They may be arranged on either the "differential" or "bridge" plan. The differential is the one more frequently employed in overland telegraphy; the bridge plan is almost invariably employed in submarine telegraphy.

THE STEARNS DUPLEX.

The Stearns duplex, is broadly speaking, operated in practically the same way as is the ordinary Morse telegraph system, namely, by the placing of a battery in the line to actuate or magnetize the home relay, thereby attracting the armature, and by removing such battery from the line, thereby permitting the retractile spring of the armature lever to withdraw it from the core of the relay.

The home battery is prevented from affecting the home relay when the home key is opened and closed in the manner described as the "differential," namely, by winding the relays "differentially." This duplex is sometimes termed the differential duplex.

In actual duplex working in which the differential or bridge plan is utilized it is necessary that the resistance of the wires attached to the respective coils of the relays, or to the arms of the "bridge," should be equal, that an equal strength of current from the home battery should tend to flow in each coil or wire.

In the arrangement of a "differential" duplex, as the main-line wire is connected to one of the coils of the relay at each terminal station, it is clear that considerable "resistance" must be connected up with the other coil to insure that the current flowing in the latter coil shall be equal in strength to that in the former coil. It is clear also that if in duplex telegraphy it were necessary to provide a wire, similar in size and length to the main-line wire, wherewith to bring about this equality of current in both coils, the main advantage of duplex telegraphy, namely, its ability to provide additional facilities for telegraphing without increased expenditure for wires, would be lost.

But such, fortunately, is not the case, for it is well known that, with a given electromotive force and a circuit of a given resistance, the strength of current will be the same, whether the conductor compos-

ing the circuit be 1 mile or 100 miles in length, 1 inch or 1 foot in diameter.

Availing of this fact, the resistance necessary to insure the equality of currents referred to is made up of "resistance coils," composed of small wire of high resistance, termed a "reostat," or "resistance box," which is constructed in such a manner that the resistance may be varied until it is found to equal the resistance of the main line. When this result is obtained the duplex is said to be "balanced." The method of obtaining this balance will be fully described.

In figure 41 the connections and apparatus of a Stearns duplex system are shown, theoretically. Two stations, *X* and *Y*, are represented and the instruments and apparatus at one station are duplicates of those at the other.

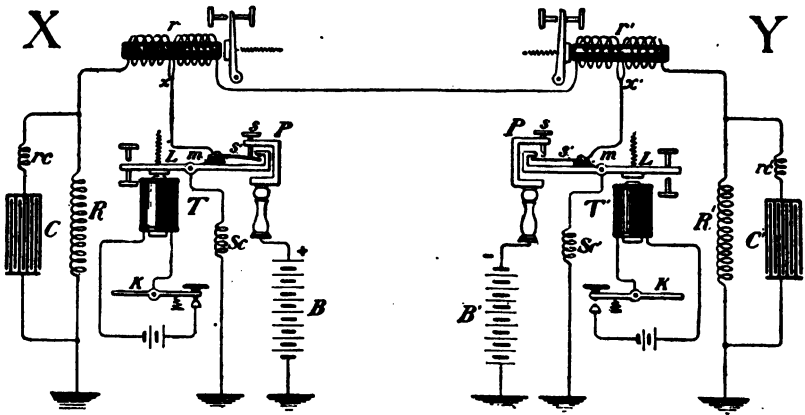

FIG. 41.

R and *R'* represent the resistance coils just referred to. In practice these coils are generally termed the "artificial" line; sometimes the compensating line.

The coil of the relay at either end which is connected to the main line is termed the "main-line" coil; the coil connected to the resistance coils, the "artificial-line" coil.

B and *B'* are the main batteries. *T* and *T'* are instruments known as "continuity-preserving" transmitters, but ordinarily termed simply transmitters. These transmitters are operated by a local battery and Morse key, as indicated in the figure. Differential relays *r* and *r'* are placed at each terminal.

CONTINUITY-PRESERVING TRANSMITTER.

The transmitter in the Stearns duplex takes the place of the key in the simple Morse system. It has, as may be seen (*T T'* in figs. 41 and 43), a lever *L*, which is bent at one end. The lever carries a piece of

insulating material M , on which is fastened a strip of metal s' , generally of steel, called the "tongue," which extends under the bent end of the lever L . A metal post or standard P , is equipped with a screw s , the lower end of which is near to and in certain positions of L touches the tongue s' , making contact therewith, as at transmitter T .

A wire leading to the line is generally connected, as shown, to the tongue, the battery wire to the post P , and the "ground" wire to the lever L . Hence, when so connected, if the transmitter be "open" the line is placed to the ground, as at T' ; and if it be "closed," battery is placed to the line, as at T .

The transmitter derives its name, "continuity preserving," from the fact that by the arrangement of the tongue s' , the screw s , and the bent end of the lever L the line wire, which is attached to s' , as shown, is transferred from the battery to the earth without any "break" in the "continuity" of the circuit.

This will be apparent from an examination of the diagram. In the figure the transmitter at X is closed. When it opens, the right end of the lever will descend, and as it does so the tongue s' will come into contact with the bent end of L , which will withdraw s' from s and leave it in the position shown at station Y , where the key controlling T' is open.

OPERATION OF DIFFERENTIAL DUPLEX.

In figure 41, as just stated, the transmitter T is closed and T' is open.

This places the positive pole of battery B to the line and leaves battery B' open, but places the line wire to the ground at Y .

The current from X divides in equal parts at x , one part passing to the main line and ground at Y , the other to the artificial line R and ground. The result is that since the current from battery B passes around the coils of r in equal and opposite directions, no effect is produced upon that relay. At the distant end Y , however, the current only passes through line coil of relay r' to the ground, and consequently that relay is magnetized and its armature is attracted.

The statement that the current only passes through the line coil of the relay at Y might be slightly qualified, since, while it is true that in the position of the transmitters in the figure the bulk of the current will pass through that coil to the ground via transmitter T' , it is the case, also, that a smaller portion of the current will pass through the artificial-line coil of r' to the ground via R' ; but, as in doing so it passes around the core of the relay in a direction similar to that in which the current traversing the line coil passes around the same core, it only assists in the further magnetization of the relay. The amount of current which will flow through the artificial coil at this time depends upon the respective resistances of Sc' and R' . The greater.

the resistance of Sc' , the resistance of R' remaining the same, the greater will be the strength of current traversing the artificial line R' . If there were no appreciable resistance at Sc' , virtually no current would pass through the artificial coil.

When the conditions are reversed and transmitter T' is closed and T is open, the relay at Y will not be affected by battery B , while the relay at X will be operated.

When both transmitters are closed simultaneously, thus placing a positive pole to the line at X and a negative pole to the line at Y , the effect will be that practically twice the amount of current will pass through the main-line coils of the relays as will pass through the artificial-line coils.

This is due to the fact that the placing of both batteries to the line has doubled the electromotive force on the main-line current, while practically only the electromotive force of one battery is placed to the artificial line at each station. This gives a preponderance of current in each main-line coil, owing to which the cores of the relays are magnetized and their armatures are attracted.

Hence, since, as we have seen, with the distant key open and the home key closed or open, the home relay remains open, it is obvious that it is practically immaterial whether battery is to the line or not at the home station so far as regards signals sent from the distant end. In other words, owing to the differential arrangement of the coils of the relays and the fact that each coil is part of a circuit of equal resistance, the home relay is only responsive to changes in the current strength due to the operation of the distant transmitter.

SPARK COIL.

In figure 41 Sc is a small resistance coil (often termed the spark coil) employed to compensate for the internal resistance of the main-line battery when the transmitter is open. The object in using this coil is to maintain a uniform resistance on the line in either position of the transmitter. For instance, assuming the internal resistance of a battery to be 300 ohms, when the battery is to the "line" this 300 ohms is added to the resistance of the line, whereas when the transmitter is "open" it would not be, normally. Thus, without the resistance referred to, placed at Sc it would likely occur that an unevenness of the signals would follow.

STATIC COMPENSATING CONDENSERS.

C C' are condensers which are employed in duplex telegraphy to impart to the "artificial" line a "static" capacity equal to that of the main line.

The necessity for the employment of condensers in this respect may be explained as follows:

Conductors, besides possessing "resistance," also possess the property of electrostatic capacity. The electrostatic capacity of overhead telegraph conductors is very much less than that of underground or submarine conductors, about as 1 to 23. This is mainly due to the proximity of the latter to the earth, and also to the specific inductive capacity of the insulating material of the cable.

The effect of charging a conductor which has a measurable electrostatic capacity is that at the moment of charge a greater rush of current takes place into the wire than would be the case if the conductor were devoid of this quality. When the battery is removed and a route to the earth provided, the accumulated "charge" rushes out in a direction opposite to that of the charging current.

The German-silver wire of which the rheostats employed as the artificial line are generally composed has, normally, no appreciable "static" capacity. The consequence is that (unless capacity is furnished to the rheostat) at the moment when the home battery is placed to the main and artificial lines, and also when the battery is cut off, a greater quantity of current for an instant flows through the line-wire coil of the relay than flows through the artificial line coil, and when the line wire is of sufficient length this excess of current is ample to cause a momentary magnetization of the core of the relay, which tends to attract the armature; or it might be that the excess of "charge" and "discharge" currents, due to the static capacity of the line, would tend to momentarily demagnetize the core, and thus permit it to be withdrawn from its contact point.

The effect of these momentary currents of static charge and discharge of the line upon the home relays are, on long lines, of such an injurious nature as to entirely prevent the successful reception of signals in duplex telegraphy when both stations are simultaneously transmitting signals, and were it not possible to compensate for this effect, not only duplex, but also quadruplex telegraphy, and especially the latter, would be impracticable. It is especially true of quadruplex telegraphy because of the much greater electromotive force used in that system than in duplex telegraphy, the static charge and discharge increasing in direct proportion with the electromotive force of the terminal batteries.

The instruments used to impart to the artificial line the quality of electrostatic capacity are the condensers referred to, C , C' (fig. 41). One terminal of the condenser at each end of the line is connected to the artificial line R , R' , the other to the earth. The condenser is provided with an adjusting arrangement by means of which its capacity is increased or decreased until it is found to furnish current which exactly offsets that due to the static capacity of the line. When such is the case the line is said to be balanced for "static." In order to bring about this balance more accurately it is sometimes essential to

use two or even three condensers, arranged in multiple and with a resistance coil inserted before each of them. In figure 41 such resistance coils rc and rc' are shown placed between condensers C and C' and the artificial lines.

Figure 42 shows the location of the apparatus in a station and the wiring connections necessary to its installation. The galvanometer shown is for the purpose of indicating when a perfect balance has been obtained.

The effect of the resistance coil is to retard and diminish the condenser charge and discharge to conform more closely to the actual conditions of the main line.

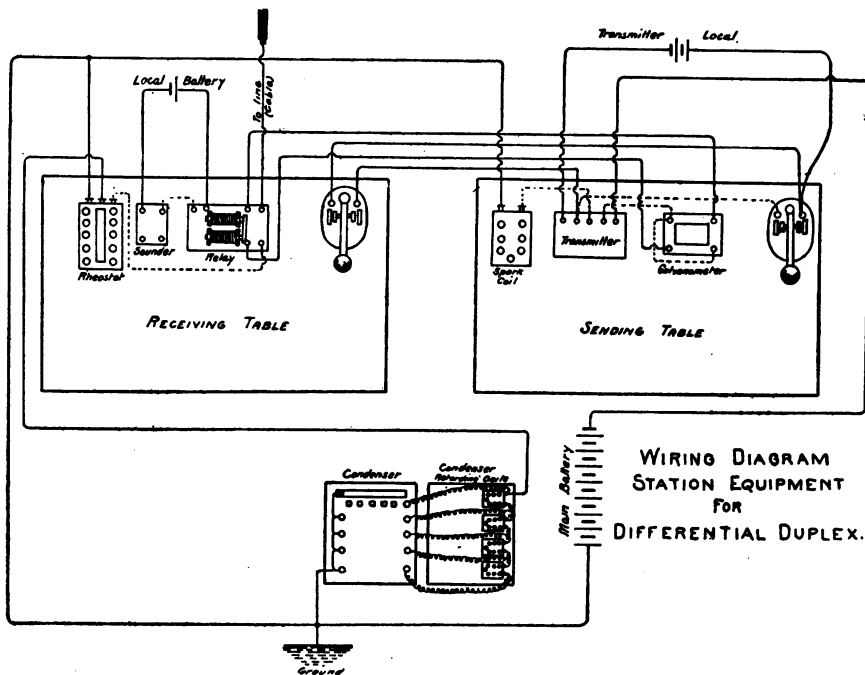

FIG. 42.

Lack of rheostat or resistance balance is shown on galvanometer or relay by steady deflection or action as long as key is depressed. Whether too much or too little is unplugged in rheostat is shown by the direction of galvanometer deflection.

Lack of static balance is shown by a "kick" of galvanometer or relay tongue at the instant key is opened or closed. The center metal strip on rheostat being connected by plugs to the resistance buttons, balance is obtained by throwing off more or less of the microfarad divisions on the condenser. A whole division is thrown off by disconnecting the wire from one of the binding posts on the left. Balance is completed by the plugs across the top division. The connections to retarding coils are shown in diagram (fig. 42). The amount

unplugged in each depends on the resistance of the cable. In a cable, for example, where the resistance is about 2,000 ohms, 400 to 500 ohms out of each box may be found about right—some changes may have to be made to suit local conditions of cable. The spark coil is supposed

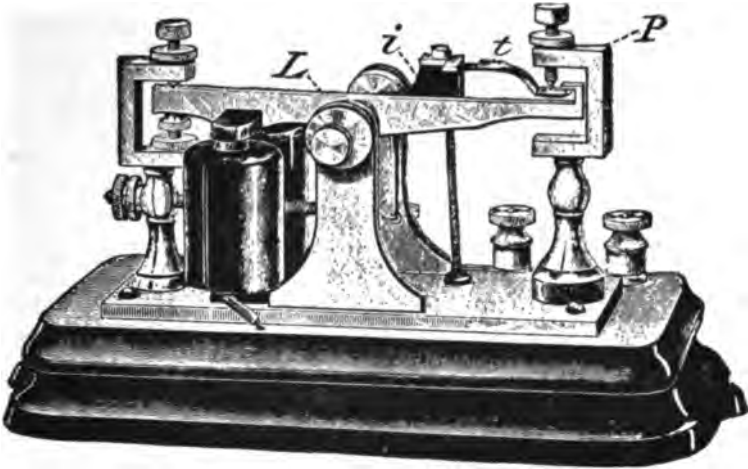

FIG. 43.

to compensate for internal resistance of main battery. Gonda cells or other good open-circuit batteries are best suited for use in differential duplex sets.

As the resistance of each Gonda cell is about 1 ohm, stations where, say, 70 Gonda cells are used, would require about 70 ohms unplugged in spark coils.

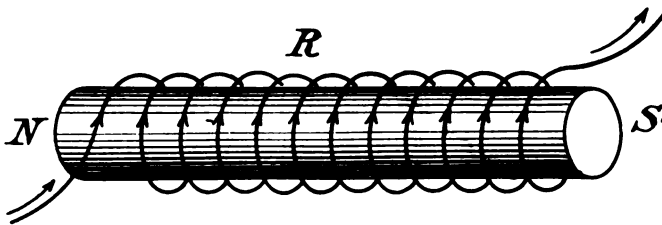

FIG. 44.

THE POLAR DUPLEX.

This duplex involves in its operation, among other principles, this one, that when a current of electricity flows in a coil of wire surrounding a soft iron core the iron not only becomes magnetized, but also that its magnetic polarity depends upon the direction in which the current flows in the coil around the core.

For instance, if, as in figure 44, the current circulates around the core from left to right, as indicated by the arrows, the left hand end

will be a north pole and the right end a south pole. If from right to left, as in figure 45, the right-hand end will be a north pole and the left a south pole. This will be the case regardless of the shape of the core.

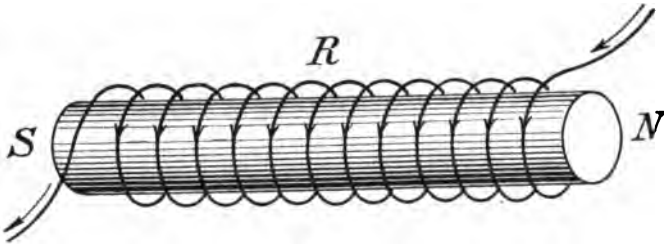

FIG. 45.

It is known that the north pole of one will attract the south pole of another magnet, and vice versa, and that the south pole will repel a south pole and a north pole a north pole. In figures 46 and 47 the north pole of a freely suspended permanent magnet *A* is placed between

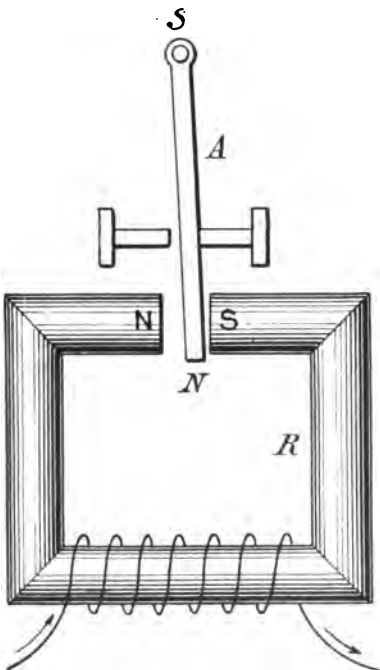

FIG. 46.

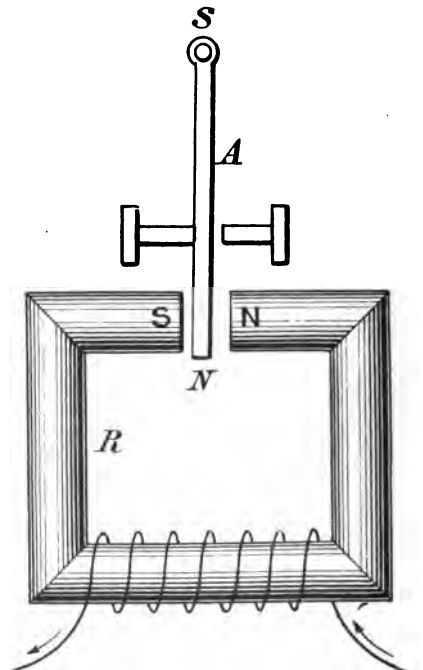

FIG. 47.

the poles of an electro magnet *R*. The direction of the current around *R* in figure 46 is, as indicated by the arrows, such that its north and south poles are as marked, and consequently *A* is attracted to the right. In figure 47 the current is in the opposite direction around *R*,

and its poles, it will be seen, are the reverse of those of *R*, figure 46, with the result that *A* is attracted to the left.

Assuming the end of the permanent magnet *A* to remain of north polarity, it is evident that if the direction of the current around the coils be reversed repeatedly, *A* will vibrate from pole to pole in response to the reversals. In such a case the permanent magnet may be considered the armature of the electro magnet, and by having suitable means for reversing the direction of the current in a circuit of which the coils in figures 46 and 47 might form a part, it would then be easy to cause armature *A* to operate a local circuit at each reversal of the current.

The instruments and apparatus presently to be described for so reversing the direction of the current and for responding to such

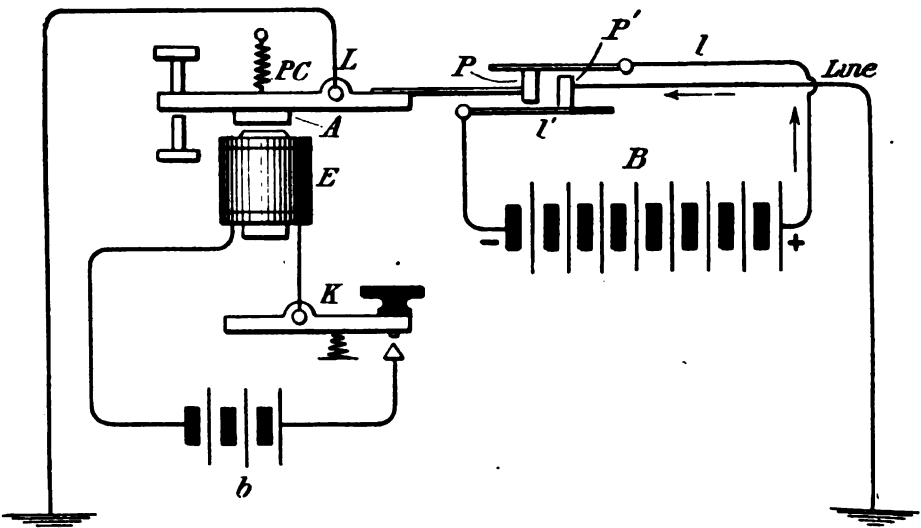

FIG. 48.

reversals constitute the more important instruments of the polar duplex.

In this duplex, in overland telegraphy, the "differential" plan is generally adopted, to avoid interference with received signals by the operation of the home transmitter.

Operation of pole changer.—In figures 48 and 49 apparatus is shown for reversing the direction of the current. In those figures *P C* is a pole-changing transmitter, commonly termed a "pole changer," designed to transpose the position of the poles of the battery as regards the circuit in which it is placed, and consequently to reverse the direction of the current in the circuit.

This pole changer *P C* is of the class known as continuity preserving pole changers, designed to "reverse" the battery with the least

possible break in the circuit. In figure 48 the contact points are purposely separated more widely than is customary in practice.

PC consists of a lever *L* carrying the armature *A* of an electro-magnet *E*; the latter being controlled by a key, *K*, and local battery *b*.

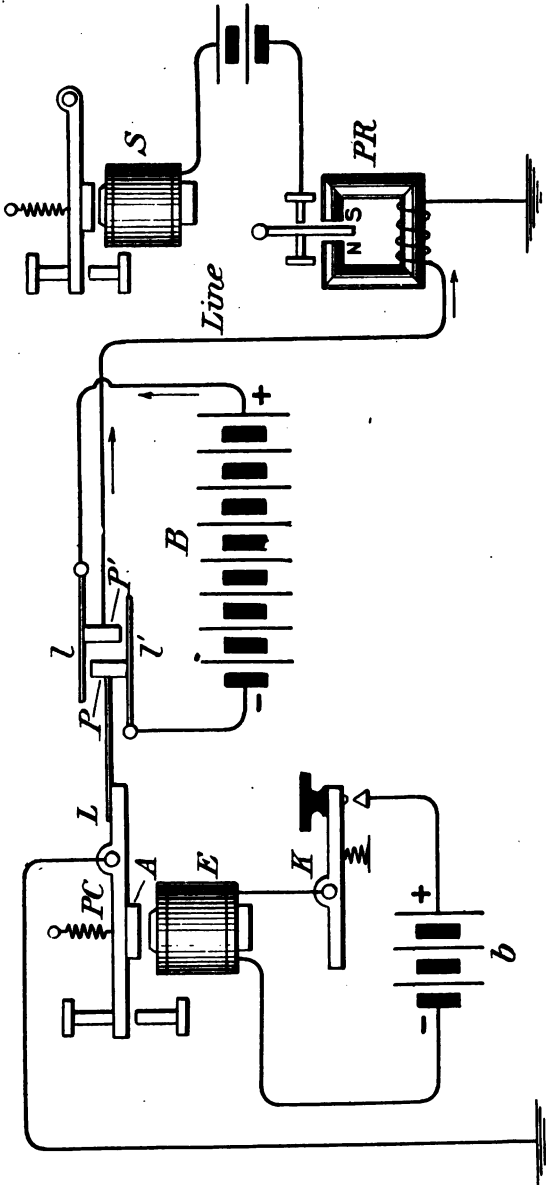

FIG. 49.

The lever *L* is extended as shown, and has a platinum contact point *P* at the end of the extension. Opposite *P* is another contact point *P'*, supported by framework, not shown in figures 48 and 49 but seen in figure 55. Metal strips, *l*, *l'* with platinum contact points are also supported on the framework and pivoted as indicated. *l* is given a downward tendency, fixed rigidly in its place. The poles of battery *B* are connected respectively to levers *l* and *l'*, as shown.

In figure 48 the pole changer is shown closed. In that position the contact *P* is in contact with *l*, while *P'* is in contact with *l'*. This, it will be seen, places the negative pole of battery *B* to the line,

and the current on the line in the direction indicated by the arrow.

When the key *K* is opened, the extension of *L* is caused to descend. As it does so the strip *l* follows *P* until it is dropped by the contact

point P' . P then severs connection with l and, descending still farther, makes contact with l' , which it pushes away from P' , the whole assuming the position shown in figure 49. The positive pole of the battery is now placed to the line, and, consequently, the direction of the current is reversed on the line, also as indicated by the arrow.

In figure 49 a relay, PR , corresponding to R in figures 46 and 47, is shown as at a distant end of the line. Its armature controls a sounder S . It is plain that as often as the battery is reversed by the pole changer the direction of the current in the coil of R will also be reversed, and, consequently, the armature A will be oscillated from one side to the other. Hence by proper manipulation of the pole changer dots and dashes will be received at the distant station.

In some countries this method of transmitting signals is used exclusively on single wires. It is known as the "double current" method. The difference between this and the Morse, or single current method, is that in the double current method the spaces are made in reality by placing that pole of the battery to the line which will cause the withdrawal of the armature of PR from its local contact point, while in the Morse method the space is made by opening the circuit, thus cutting off the battery from the line.

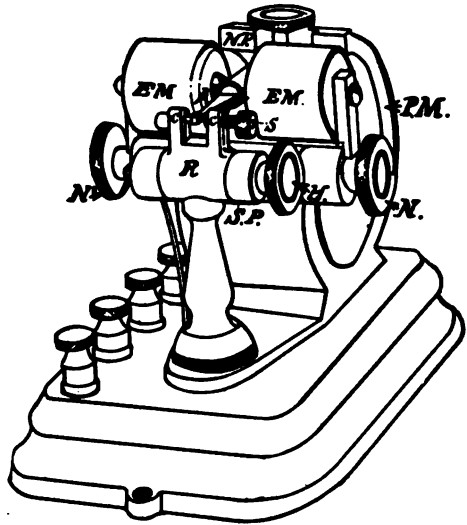

FIG. 50.

One form of this instrument, very generally used in duplex and quadruplex telegraphy, is shown in figure 50. It is known as the Western Union polarized relay.

The polarized relay is a combination of a permanent magnet and an electro-magnet. The electro-magnet consists of short cores made of the best Norway soft iron, surrounded (when intended for differential duplex working) by "differentially wound" coils, each having a resistance of about 400 ohms. In some forms of polarized relays the core of the electro-magnet is extended beyond the edge of the coil so as to bring the poles face to face. These extensions, which are also of soft iron, are termed pole pieces.

A permanent magnet, PM , figure 50, bent to the shape shown, rests on the baseboard of the instrument. These permanent magnets are formed of steel and are very retentive of magnetism. On the lower

end SP of the permanent magnet the crosspiece of the electro-magnet rests. The crosspiece of the electro-magnet is a strip of soft iron connecting the two cores of the electro-magnet in the usual way. To the upper end NP of the permanent magnet is pivoted, at X , a soft iron tube, A , which extends between, and somewhat beyond, the poles of the electro-magnet. This is the armature of the polarized relay. This armature is constantly magnetized by its nearness to the permanent magnet PM . Assuming the end NP of the permanent magnet to be its north pole and SP its south pole, the armature A will be magnetized so that its end between the poles of the electro-magnet will be a north pole, and the ends of the cores of the electro-magnet, which are also magnetized by contact with the permanent magnet, will be south poles; that is, during the time that no "magnetizing" current is flowing through its coils. The term magnetizing current is used here advisedly, because of the fact that, in a "differential" relay, the current does not magnetize the core until an excess of current flows through one of the coils.

When, therefore, there is no magnetizing current in the coils of EM , the armature A , which, having no retractile spring, when placed exactly in the "center" between the two ends of EM , will be attracted equally by both ends, since a south pole on each side is "pulling" with equal strength at a north pole.

But, if the armature be placed nearer one pole face of EM than the other, it will be held toward that face or end. Consequently, under the conditions stated, the armature will stay on whichever side it is last placed. When, however, a magnetizing current passes through the coils of the electro-magnet, the magnetism in its core (due to the permanent magnet) is either increased or overcome, and its ends become north or south poles according to the direction of the magnetizing current, and the armature A is attracted by the south pole of the electro-magnet and repelled by the north pole.

The magnetism of the electro-magnet of the polarized relay changes in response to the reversal of the distant battery, and the armature vibrates to and fro between its front and back stops in accordance with those changes.

It is obviously essential that the magnetism of the permanent magnet should not be reversed by the reversals of magnetism of the electro-magnet, otherwise the magnetism of the armature A would be reversed also, and would fail in that case to respond properly to the reversals of the distant battery. Since the armature does respond properly, it is evident that the permanent magnet is not materially affected by the magnetic reversals of the electro-magnet. There may be a slight tendency to so change on the part, as it were, of the electro-magnetism of the electro-magnet, but, owing to the point at which the permanent magnet is connected to the cores or crosspiece of the

electro-magnet—that is, at its “neutral” point, namely, at the middle of the cores—any such effect is not perceived in practice.

The play of armature of the Western Union polarized relay is adjusted by means of the small screw *S*. Its position between the cores of the electro-magnet is regulated by the position of the front and back contact points *c*, *c'*. These contacts ride in a carriage which is movable, within certain limits, in the cylinder *R*.

The carriage is movable back and forth by the screw *H*. The armature may be placed directly in the “center” between the two poles of the electro-magnet by the movement of the screw *H*. The cores of the relay may be independently moved to and from the armature by the screws *N N'*.

A form of polarized relay, a modification of what is known in Europe as the Stroh relay, now the standard of the Western Union Company, is shown in side view, figure 51. Its chief working parts are inclosed in a brass case with an ebonite top, in which there is an

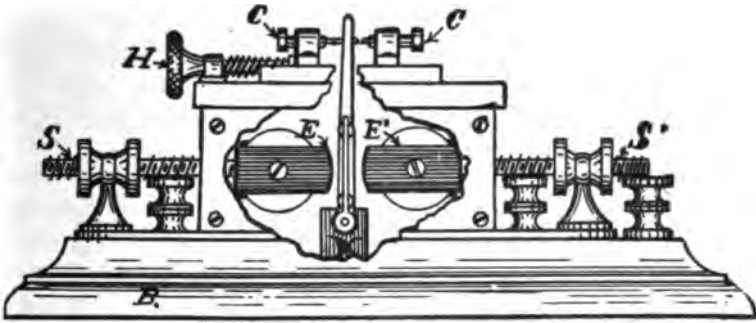

FIG. 51.

opening through which the armature lever comes. There is also a small opening in the sides of the brass case through which the pole pieces of the electro-magnets can be observed for purposes of adjustment. In the figure this opening is enlarged in order to show more clearly the relative positions of the coils *E E'*, pole pieces, etc. In this relay an ordinary horseshoe magnet is employed as the permanent magnet. It lies horizontally under the base *B* of the relay as outlined in figure 51, which is a side view of the relay. The relay has two electro-magnets with separate cores. In this form the electro-magnets lie horizontally, lengthwise, with pole pieces facing, and the armatures are vertical, lengthwise, the lower ends of the armatures being loosely inserted in a recess in short iron extensions from the respective ends of the permanent magnet by which the armatures are inductively magnetized. The pole pieces extend across the ends of the coils, but are connected to the cores as indicated. The pole pieces and coils are moved to and from the armature by means of the adjusting screws *S S'*.

The local-contact point and back stop *C C* are movable in a frame which is adjustable by the screw *H*. The moving parts of this relay are much lighter than in some of those previously in use by this company, the light, nonmagnetic metal aluminum being used wherever practicable. As intimated, the relay has two separate armatures, which, however, are carried on a common frame, which is outlined in figure 52. This frame is pivoted at *f f*. *A A* are the soft-iron armatures. *A 1* is the armature lever, also of aluminum.

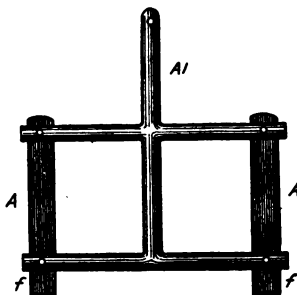

FIG. 52.

THEORY OF THE POLAR DUPLEX.

The theoretic connections of a polar duplex at two stations, *X* and *Y*, are shown in figure 53. In this, *P C* and *P C'* are the pole changers. *P R* and *P R'* are differentially wound polarized relays. *B* and *B'* are main batteries.

R R' are rheostats, or coils of insulated wire, adjusted to equal the resistance of the main-line wires. This, it has been explained, is necessary in order that, when the distant end is "grounded," the same

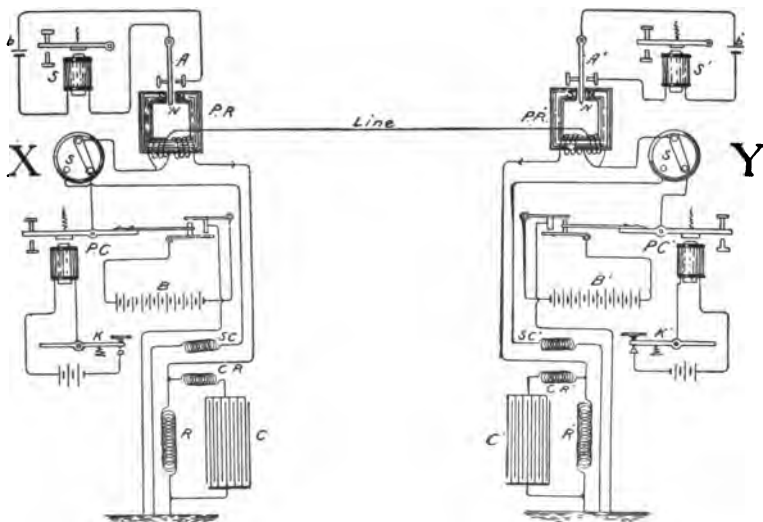

FIG. 53.

amount of current shall flow through each coil of the differential relays, which will be the case when the resistance of the rheostats equals that of the main line.

In figure 53 the pole changers at both ends of the line are open. This places the positive pole of batteries *B* and *B'* to the line. As

these batteries are supposed to have an equal electro-motive force, no current flows over the main line. But a current from the respective batteries $B B'$ flows to "ground," via the artificial lines, in a direction which so magnetizes the cores of $P R$ and $P' R'$ that their armatures are withdrawn from their local-contact points, thus leaving the sounders open. It may perhaps be useful to explain these statements. When the terminals of a wire are at similar potentials no current will flow in that wire. In the case in point, when positive poles of equal electro-motive force are placed to the main line at each station it is plain that the terminals of that wire are at similar potentials. In the case of the artificial wires, on the other hand, the distant terminal of each is at zero, under which conditions, of course, a current will flow in these wires.

If, now, the pole changer $P C'$ at Y be closed, it will place a negative pole to the line.

That action should reverse the magnetism in $P R$, but should have no effect on the relay $P' R'$ at Y . That such is the case we shall see. It is here suggested to the student that he draw diagrams to show these changes, inserting arrows to indicate the changed direction of the current.

With the positive pole to the line at X and the negative to the line at Y there will be twice the current flowing over the line wire that flows through the artificial lines. Before the reversal of $P C'$ the current was flowing only through the artificial-line coil of $P R$, shown by the arrow, etc. After the reversal that current continues to flow, but now there is a current of twice its strength flowing in the main-line coil around the core of $P R$ in an opposite direction. The result is that the magnetism of the core of $P R$ is reversed and the armature A is moved over against its local-contact point, closing the local circuit. So far the result desired is brought about. Now, let us see whether the polarized relay, $P' R'$ at Y , has been affected by the action which has reversed the polarity of $P R$ at X .

Before the reversal of $P C'$ a current was flowing only through the artificial-line coil of $P' R'$ in the direction shown by the arrow. After the reversal of battery B' twice the current flows through the main-line coil that flows through the artificial-line coil, but its course through the main-line coil is in the same direction, around the core of $P' R'$, as was the current which previously flowed through the artificial-wire coil, so that the magnetic polarity of $P' R'$ remains unaffected and its sounder continues open.

If the pole changer at X should also be closed, that action will place a negative pole of battery B to the line. The result will be that, since the pole changer at Y is also closed, the negative pole of B' is to the line, consequently no current will flow over it. But now the current through the artificial-line coil is in an opposite direction around the

core to that which had made its magnetism north and south, as marked at its poles in the figure, and hence its magnetism is changed and the sounder is closed. It will also be found on examination that this reversal of the battery at X has not affected the relay at X , although the magnetizing current has been transferred from the main-line coil to the artificial-line coil.

From all of which it is evident that, with a proper "resistance" and "static" balance, the home relays will not have their magnetism changed by reversals of the home batteries, regardless of whether the poles of the batteries at the respective ends of the wire oppose or assist each other.

BALANCING THE POLAR DUPLEX.

The polar duplex is balanced by asking the distant station to "ground." This he does by throwing the 3-point switch s , figure 53, to the left. (Sometimes the left-hand lower "point," or disk, is connected to the earth via SC , sometimes it is the right-hand lower point that is so connected.) This action disconnects the pole changer and battery from the line and transfers the latter to the earth via the resistance coil SC or SC' . These resistance coils are inserted, as in the Stearns duplex, to compensate for the internal resistance of the battery at each end. When the distant switch has been turned the home switch is also turned similarly. The adjusting screw of the polarized relay is turned forward or backward until the armature remains on whichever side it may be placed. The home battery is then placed to the line by turning the switch s to the left. Then the pole changer is opened and closed and the resistance in R or R' is adjusted until the armature of the relay remains on either side, as before. This insures a "resistance" balance. The pole changer is now closed and opened rapidly, and if short clicks are heard the capacity of the condenser is varied until these disappear altogether. This shows that a "static" balance has been obtained. A static balance can also be got by asking the distant station to "cut in," which he does by turning the switch to the right. When he has done so, ask him to close his key, so that the armature of the home relay will rest against its contact point. The armature may then be given a slight bias away from its contact point and the home pole changer again operated. If clicks are still heard in the sounder, the condenser and its resistance coil are adjusted until they disappear, when the distant end may be asked to write a few words, to give an opportunity to readjust the armature to its proper place. As a rule, however, a good working static balance can be obtained on a polar duplex without giving the armature of the polarized relay a bias.

A diagram of actual connections of a polar duplex "set" at one station is given in figure 54, with a gravity, or other chemical battery,

as the source of electromotive force. The dotted lines represent the small wires connecting the apparatus to the binding posts. In the figure the polarized relay is shown with front and back local contact points leading to screw posts 6 and 7, respectively. The polar relay is not always equipped in this way, binding post 7 being generally omitted.

But the former arrangement is often useful, as it affords an easy means of putting the sounder on the "front stroke" when the distant battery connections are reversed, which frequently happens in practice. *C R* is the condenser resistance. *A S* is a 3-point switch used

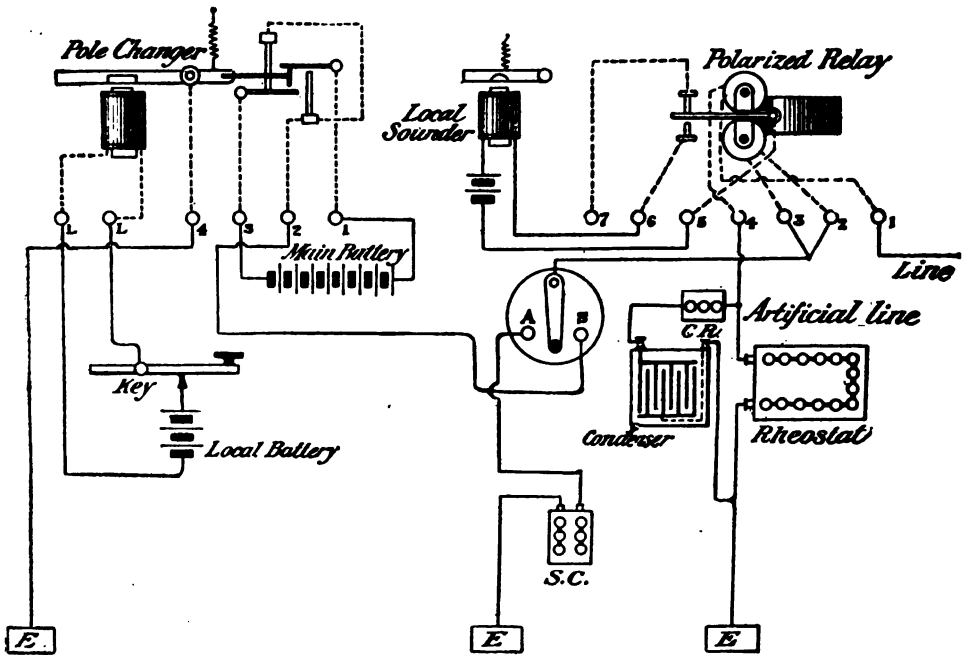

FIG. 54.

in "grounding" the line. *S C* is a "spark coil" or resistance box adjusted to equal the internal resistance of the main battery. The other instruments are as marked.

WESTERN UNION POLE CHANGER.

The Western Union standard pole changer for gravity batteries is shown in figure 55. The contact points of the instrument are inclosed in a circular glass-incased box. The end of the lever *L* is seen extending into the box through an aperture in the back of the framework. The tension springs *S S'* are insulated from the box. The contacts *C C'* are attached to the framework. The poles of the bat-

tery are generally connected to the springs $S S'$ by way of their respective binding posts on the side of the baseboard. The lever is connected to the earth, and the contact points $C C'$ to the line, or vice versa, as desired; also via the binding posts.

THE ADJUSTMENT OF TELEGRAPH APPARATUS.^a

If operators in general could be made to realize how much more comfort they might taken in their daily work did they but acquire even a slight knowledge of the *knack* of adjusting their instruments properly, they would certainly make a move in that direction for

their own interest if not for that of the company employing them.

There is positively no excuse for the indistinct manner in which signals are so frequently recorded on the really first-class instruments employed by telegraph companies to-day. When the signals do not arrive in proper shape there is some good reason for it, but the theory of the fault given by the average operator is usually wide of the mark, and as he "ad-

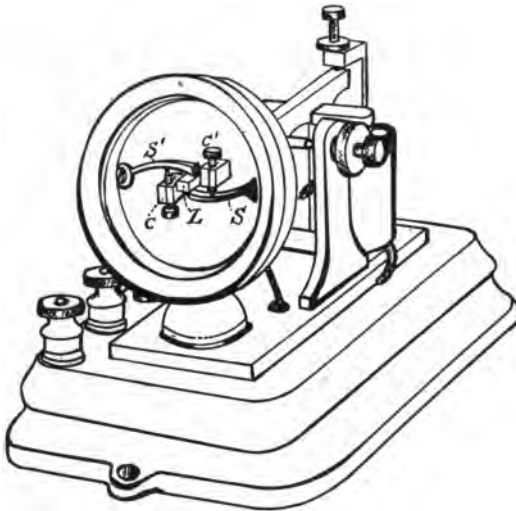

FIG. 55.

justs" in accordance with his ideas of the trouble, he generally makes matters worse by such efforts.

For the purpose of demonstration let us see what may be learned in the way of adjustment and care of an ordinary single-line relay and sounder. Now, we will assume that the wire, battery, and instrument coils are in first-class order and then introduce a few conditions for the purpose of noting the different effects produced on the apparatus.

WET-WEATHER EFFECTS.

In wet weather the quantity of current which traverses the coils of a relay is greatly increased at or near the battery station over and above that which normally flows in clear weather, while distant-station instruments receive less than the usual amount. This condi-

^a By Willis H. Jones, in the *Telegraph Age*, September and October, 1902.

tion is caused by the numerous "escapes" or side paths down the poles along the route which draw additional current from the dynamo, all of which must necessarily pass through the relays inserted between them and the battery. Distant relays receive less than they are entitled to, because much of the current on the wire "escapes" down the wet poles before reaching them. Now, a strong current in the coils means a strong magnetic pull on the relay armature, while a weak current, of course, causes a correspondingly weak attraction.

It follows from this that the wet-weather method of adjusting a distant relay is directly opposite to that followed for the home relay at the battery end of the circuit. The operators at distant points must get the magnets closer and closer to the armature as the downfall of rain increases, while the home operator is compelled to draw his relay coils away from it. This seems like a very simple operation to perform, but the manner in which most operators go about it explains why they fail to secure the best results.

Now, the first principle of adjustment lies in maintaining at all times, whether the current is weak or strong, a practically constant or normal tension of the retractile spring attached to the relay armature. The explanation is that a relay spring responds best to the magnetic attraction of the armature when the tension is such that the "curling" is not stretched to any great extent out of its original close-fitting construction when new.

The adjustment should invariably be done by moving the magnet backward or forward by means of the thumbscrew. The tension of the retractile spring need not be altered perceptibly except to give the operation a finishing touch. The habit of stretching the relay spring to meet a strong magnetic pull not only causes the former to work less efficiently at the time, but soon injures it permanently by destroying its sensitiveness.

FEELING FOR A DISTANT STATION.

It frequently happens in very wet weather that a distant office can not break the operator at or near the battery station on account of the difficulty the latter has in getting a fine adjustment. When informed via some other circuit that such is the case the best method to pursue is as follows: Make a few dots to attract his attention (he will hear you; the distant office has the advantage in this respect) and then tell him to "dot." Now pull the magnets back from the relay armature until the circuit stands apparently just open. Next, turn down the retractile spring very slowly until you hear the signals. If you miss them, you may sometimes catch them by placing your finger on the lever of the relay and giving it a gentle pressure back and forth. If the operator is dotting, you will feel the impulses and thus be able to readjust the instrument.

The latter method is an excellent one to pursue on a way wire when in doubt as to whether anyone is using the circuit, for by this precaution one operator need never break in while another is sending. However, as it is only in very wet weather that an operator is bothered to any great extent by the relay, the real source of daily discomfiture usually lies in an improper adjustment of the sounder.

ADJUSTMENT OF SOUNDERS.

When a sounder does not give out a loud enough tone to suit an operator, he almost invariably proceeds to give the lever a wider play, as if that was the only remedy. As a matter of fact that process in itself seldom brings about the desired results unless the lever at the time happens to be screwed down abnormally close. The important thing to know is that if you give the lever a play which will permit the armature to move away from the magnet cores beyond a normal distance, the magnet has a hard time getting control of it again. The explanation is that a magnet loses its power to attract the armature in a degree directly proportional to the square of the distance separating them; or, in other words, to the square of the air gap. For example, if two magnets similarly constructed in all respects be fed by an equal strength of current, and the air gap between the cores and the armature of one made the thickness of a cardboard, while two cards could occupy the gap in the second magnet, the former would be practically four times as strong as the latter. It is plain, therefore, that to give the sounder lever too great a play will so weaken the pull on the armature when in its "open" position that when the local circuit is again closed the lever moves so slowly at first that it hardly has time to cross over the space before the current is again broken. The result is that a signal is partially broken up before completion.

The lesson to be learned from this is that the play given to an armature lever must never be so great that the magnet can not bring it back promptly within the time allotted to complete a signal. This, in turn, suggests that the amount of play given should be decreased in proportion to the speed with which the signals are increased. The proper method to increase the volume of sound is as follows:

ADJUSTING FOR MAXIMUM STRENGTH.

Place a sheet of paper between the armature and the poles of the sounder magnet and then lower the former until there is just space enough to move the paper back and forth without catching. This permits the magnet to exert its maximum strength on the lever, and the position should seldom be altered. Whatever changes are necessary during the process of adjusting should be effected by means of the spring, the upper thumbscrew, and those which regulate the trun-

nion. The adjustment of the trunnion screws is a matter too generally overlooked. It is there that the pitch or quality of the sound is regulated. The pivot must not bind too tightly, nor yet be too loose.

When signals do not reach the operator in the particular style that suits his fancy, he usually attempts to remedy the fault by giving the sounder lever a greater or a lesser play. If the trouble happens to lie in an improper adjustment of that part of the apparatus he may possibly succeed in helping matters, but the fact is that indistinct signals may be due to a great variety of causes, any one of which, in his ignorance, he may never suspect.

For the purpose of illustration, let us again take the case of an ordinary single-line relay and sounder and assume that despite a careful adjustment of the relay and sounder magnets after the manner suggested in the preceding installment of this article the signals continue to "drop out" at times.

Now, the first thing to determine is whether the fault lies in the relay or the sounder. Such disturbances are usually due to a loose or improper connection somewhere in the local circuit, but not always. Naturally the first move made toward locating the trouble should be to examine all binding posts, and operators in general would save themselves many annoyances if they would acquire the habit of doing this whenever they sit down to a different set of instruments. If the binding-post connections prove to be secure, open the key and "dot" or "write" with your finger on the relay armature or lever, using the latter as a key. If the signals then respond firmly and distinct, the local circuit is not to blame, and attention should be directed to the relay.

In many cases the source of the trouble will turn out to be too tight an adjustment of the trunnion binding posts, thus preventing the restrained armature from responding readily to the influence of the magnet. This fault is particularly applicable to circuits in which the strength of the current flowing through the relay coils is weak. Where the main-line current is strong, the magnet is frequently able to overcome this drawback, but it is evident that even then the working margin of that instrument has been cut down to the extent that the trunnion binds. It follows, then, that the trunnion binding posts should always be so adjusted that the cross bar or axis upon which the lever and armature rests may move perfectly free in its sockets.

If, however, the signals made in the manner suggested continue to drop out despite this precaution, the fault will possibly be found in a loose connection somewhere in the local circuit. If tightening the binding posts fails to remove the trouble, examine the fine wire wound around the shaft of the relay lever, one end of which is attached to the shaft and the other to a part of that trunnion binding post where

the local battery makes its exit. If this wire becomes broken, the sounder signals will certainly "drop out" at times owing to the loose connection made between the shaft and the post as the former turns in the socket. The purpose of the fine wire is to bridge over this unavoidable break in the local circuit, and the operator will at once see the necessity of keeping that connection intact.

When a sounder stands "open" and it is desired to ascertain if the break in the local circuit lies in some of the relay connections, place the blade of a knife across both local binding posts (situated just behind the relay spring). If the opening is in that instrument, the sounder will then close. If the latter remains open, try the same method with the two posts of the sounder itself. If the coil or wire connections there are broken, a spark will be noticed the moment the blade makes and breaks contact with the two posts. The sounder, however, will not close, because the magnet coils are cut out.

The knife-blade method, however, should never be resorted to where sounders are connected up in multiple, such as is usually the case in our large modernly equipped offices, because the cutting out of the coil draws so much current through the low-resistance route via the blade that it melts the fuse and opens the other four or five companion sounders comprised in that particular group. Operators see this fact demonstrated nearly every day in large telegraph offices when some one thoughtlessly or ignorantly permits a steel penholder or other piece of metal to simultaneously make contact with both binding posts of the sounder or resonator connections. When this occurs, the "locals" go off on several adjacent desks and business is suspended until a new fuse is substituted. The blade may be placed across the local posts of the relay, however, because it will not cut out the coils of the magnet, hence the resistance is not lowered. It may also be done where the sounder coils are in series with a loop or lamp resistance, such as the arrangement obtaining on duplex and quadruplex circuits.

It will be seen from what has already been said that the adjustment and understanding of even an ordinary relay and sounder requires considerable skill and a fair degree of electrical knowledge, yet an operator who does not possess ambition enough to interest himself to the extent of understanding the instrument before him certainly deserves much of the needless provocations which come his way.

Up to this point the suggestions concerning various methods of adjusting telegraph apparatus have been confined to the receiving instruments. The sending apparatus, however, demands quite as much attention and skill on the part of the operator as the receiving instruments do.

Operators, as a rule, hardly realize the fact that with but a very little study on their part it lies within their power to not only make their own work much easier, but that also of the man at the distant end of the circuit.

One of the most common mistakes the operator makes is to find fault with the key frequently because of his inability to send fast or to make the Morse alphabet easily. It may surprise many readers to learn that as a matter of fact the key is seldom to blame. It is really a matter of what is called the electrical and the mechanical inertia of the instruments that cause the trouble.

For example: In a telegraph wire, where there are a great many offices close together, such as we find on some railroad circuits, there are necessarily many relays, the highly wound coils of which compose the greater part of the total resistance. Where such a condition exists the counter electromotive force developed within and by the coils is so great that it checks the quick action of the current in its operation of building up the magnetism in the iron cores of the relays, and thus demands a slower rate of speed on the part of the sending operator in order to fully form his characters. Unless he complies with this law the second impulse in the formation of a character will be begun before the preceding one has been fully "built up," with the result that the key will "stick," as he erroneously believes, and the key gets the blame.

With sounders, as usually arranged, the case is different, but the effect is just the same. If you give the lever of a sounder an abnormally great degree of play, and then make "dots" exceedingly rapid, the lever will probably remain in an "open" position during the experiment. Decrease the speed somewhat and it will respond indifferently. If, however, you open and close the key very slowly, the lever will follow the movement faithfully. Finally, if you adjust the lever armature close to the magnet and give it but very little play, every "dot" will be heard, no matter how fast you make them.

The lesson to be learned from these experiments is that where speed is required the lever must be given as little play as practicable in order to reduce the mechanical inertia to a minimum. Where an operator ignores this rule, in order to get a greater volume of sound to receive by, he will experience the same difficulty in forming the alphabet as his friend with the choked relay did, and probably vie with him in condemning the greatly abused key.

The application of these lessons is directed principally to those in charge of duplex and quadruplex apparatus, and cautionary to operators in branch offices working sounders on legs or loop extensions. On account of the tongue and the retractile spring on transmitters, and the accuracy with which pole changers must be manipulated, those

instruments demand very careful adjustment to the speed of the transmitting operator. Sounders, on the other hand, once properly adjusted, respond so clearly (on the transmitting side) that operators in branch offices working on duplex loops find that the sending side works, apparently, as well on a poor wire as a good one. The result is that in bad weather the fact is frequently overlooked that the pole changer or transmitter, as the case may be, can not perform their functions properly at a dry-weather speed, and thus by maintaining their usual speed cause no end of trouble both to themselves and the quadruplex chief at the main office.

CHAPTER IV.—BUZZERS.

THEORY OF THE BUZZER.

The principle upon which the field buzzer operates depends upon the effects of self-induction; i. e., the comparatively high self-induced voltage developed at the terminals of an electromagnet (coil with iron core) when the current through the circuit is suddenly interrupted. The interruptions are automatically produced by a circuit breaker, which is described later.

When a current of electricity begins to flow through a conductor, magnetic whirls spring outward from the conductor and surround it with a magnetic field of force, which is evidenced by the deflection of a freely suspended needle, parallel to the conductor, when approached by the conductor. During the interval of time required for the current to reach its maximum value, the field of force expands in direct proportion to the current strength until it also reaches maximum value. The current strength being kept constant, the magnetic field is of constant value. Any variation in current strength produces a corresponding variation in the strength of the magnetic field; therefore, when the circuit is broken and the current rapidly falls to zero the field of force also collapses and disappears. The energy furnished by the current and stored up in the magnetic field is thus returned to the circuit and tends to sustain the original current, as is noticed by a bright spark appearing at point of break.

On "make," then, the whirls spring out from and cut the wire, inducing therein a current opposed in direction to inducing current. On "break" the whirls collapse, again cutting the wire and inducing therein a current having same direction as inducing current. The phenomena resulting from the cutting of a wire by magnetic lines of force is called self-induction.

When the circuit contains a coil, the above-noted effects of self-induction are much greater. If the coil contains an iron core the effects of self-induction are still more pronounced.

To make clear the action of the buzzer let us consider the following diagram (fig. 56):

B is a battery of 5 dry cells; *K* is a key for making and breaking the circuit; *E* an electromagnet; *R* a telephone receiver.

When the key is closed there is a rush of current which reaches its maximum strength almost instantly. Simultaneously there is built up a magnetic field of force around the electromagnet. Now, if the key be opened, a pronounced click, of momentary duration, is heard in the receiver, which is caused by a self-induced current of high E M F produced by the collapse of the magnetic field around the

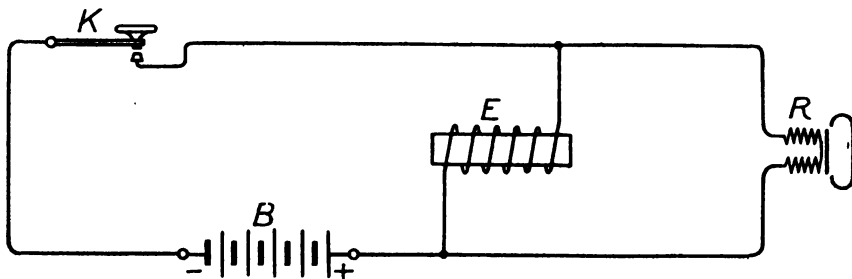

FIG. 56.

coil. This induced current would spark across break at the key if there were not an alternate complete circuit through the receiver.

The more rapidly the circuit is made and broken by closing and opening the key, the greater the rapidity with which clicks in telephone follow one another, until, if the interruptions recur sufficiently often, the sounds in the receiver appear to be almost continuous.

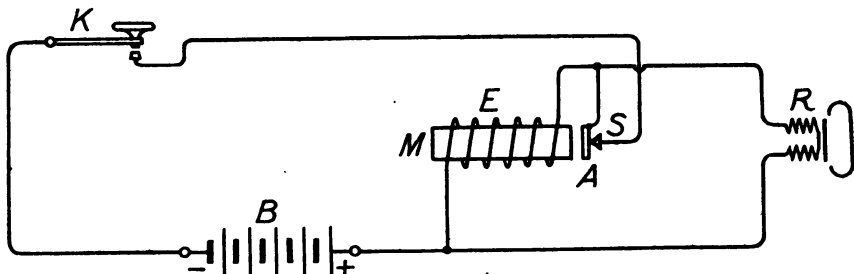

FIG. 57.

If we introduce an automatic interrupter into the circuit (fig. 57), a loud buzzing sound is heard in the receiver whenever the key is closed, and the dot and dash of the Morse alphabet are thereby produced by making short and long contacts with key.

The action of the interrupter or circuit breaker is as follows:

When the circuit is made by closing the key *K*, the current flows through coils of the electromagnet *E*, magnetizing the iron core *M*, which, in turn, attracts armature *A*. As soon as the armature is withdrawn from contact *S* the circuit is broken; as a result, the core becomes demagnetized and armature *A* springs back against *S*, thus

again closing the circuit. This action continues so long as key *K* is kept closed.

If, instead of key and interrupter, we substitute therefor a transmitter (fig. 58), then when the key is closed current flows from + side of the battery through the coil to the lower disk (stationary) of transmitter, through loosely packed carbon granules to upper disk (movable) which is attached to the diaphragm, to - side of battery.

Except when this circuit is first made, there is no evidence of self-induction in the circuit until the transmitter is spoken into, then the sound waves of the voice, striking the diaphragm, cause it to vibrate; the carbon granules between the carbon disks are thus subjected to varying pressure; this causes a variable resistance in the circuit, and the resulting current is a pulsating one (uniform in direction, but varying in strength). The effect of the varying current passing through the circuit is to increase and decrease the field of force built up around the wire. This changing field of force in turn produces

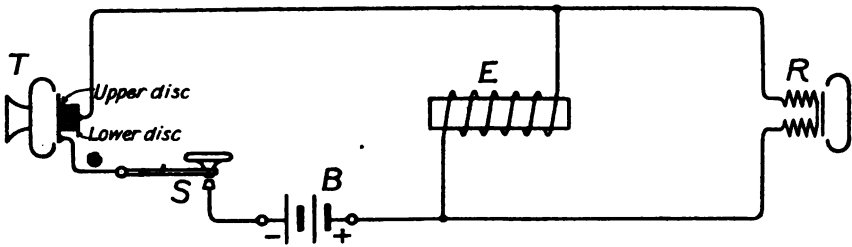

FIG. 58.

the effects of self-induction, and these effects are particularly noticeable in coil *E*.

The inductive property of the coil is thus employed to augment the comparatively weak primary current to one of high E M F, which intensifies the vibration of the receiver diaphragm; these vibrations being received by the ear as articulate speech.

The sounds thus produced are not as loud as those produced by the interrupter even though the same number of cells are used, for the reason that in the latter case the current is completely interrupted (circuit broken), whereas in the case of the talking circuit, current is always flowing, but is varied in strength; therefore the resulting field of force never reduces to zero, the cutting of the wire is consequently less, and the effects of self-induction are diminished.

If we now combine the two circuits described above in one diagram, we have the simplified buzzer diagram which is shown below. (Fig. 59.)

An examination of this figure shows that the only changes made is the introduction of two terminal binding posts, one of which is con-

needed to the line, the other to the ground. If a similar instrument is connected at the distant station, the currents traversing home receiver also pass through distant receiver.

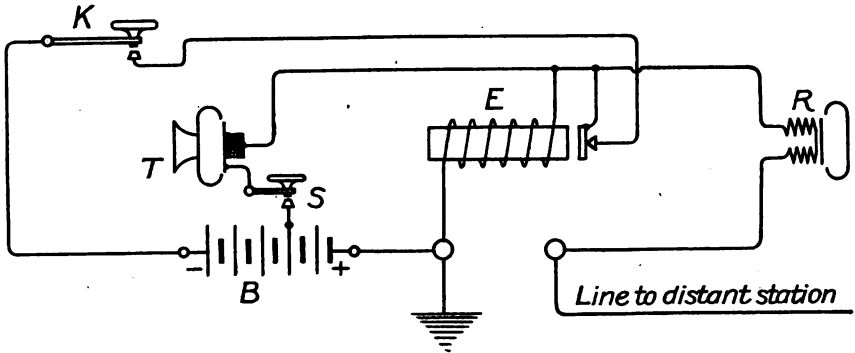

FIG. 59.



FIG. 60.—Field buzzer.

FIELD BUZZER MODEL 1908.

This instrument is shown in accompanying photographs. (Figs. 60 and 61.) The leather case containing the instrument is $8\frac{1}{4}$ by 6 by

6½ inches; weight, 9 pounds. This case is divided into two compartments by a vertical partition. One part contains 5 cells of dry battery, a condenser having a capacity of 0.05 microfarad, and a resistance coil of 25 ohms. The other part holds a head receiver and a transmitter. A hard-rubber plate covers the last-named compartment, and this plate supports a simple make-and-break key, a circuit breaker, a buzzer coil, together with the line and ground binding posts.



FIG. 61.—Field buzzer.

PRIMARY CIRCUIT, BUZZER.

From + side of battery to *K*, through lever of key when closed, to screw *D*, which passes through and is insulated from base *E* to spring *S*, which is kept in contact with armature *A* by insulated tip adjusting screw *N*, along armature *A* to iron cylinder *F*, which is in metallic contact with *A*, through coil *B* to screw *H*, which passes through and is insulated from iron cylinder *F*, to — side of battery.

When the above circuit is made by closing key the action that takes place is that described under "Theory of the Buzzer."

It has been shown that when an electrical circuit, composed in part of a coil as shown at *B*, is made and broken in rapid succession the effect of the self-induction produces on break a self-induced current of high E M F, which tends to sustain the original current by passing across the break (*A S*); and further, that unless some alternate cir-

cuit is furnished a bright spark would be noticed between these points. With terminals *L G* disconnected this induced current charges condenser *C*. The condenser immediately discharges back through battery, *H, B, F, I* (condenser circuit bridging break). From this it is seen that the function of the condenser is to prevent sparking at break. The condenser is in series with coil *I*, the effect of which is to prevent abnormal charging of condenser. With terminals *L G* connected to line and ground, respectively, assuming another instrument properly connected at distant station, the self-induced discharge from coil *B* has, in addition to the path through condenser, another circuit called the secondary circuit.

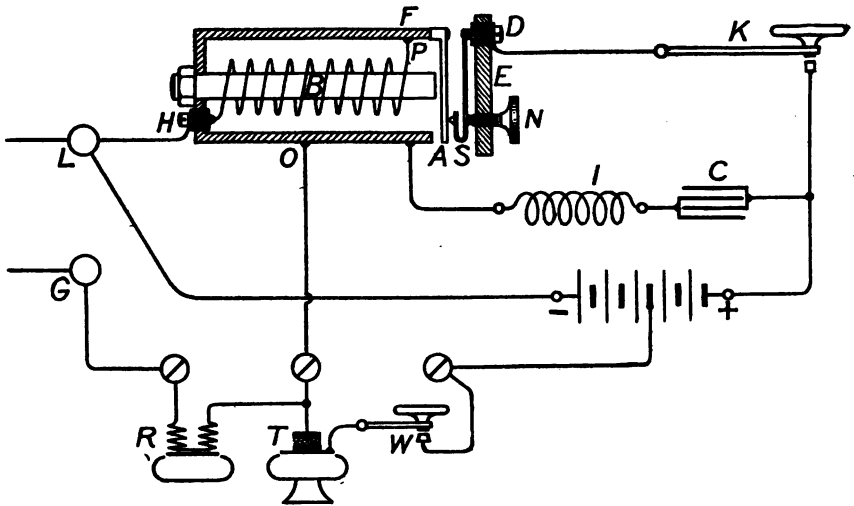

FIG. 62.

SECONDARY CIRCUIT, BUZZER.

From *B* to *H, L* line to distant station return through ground to *G*, receiver, *O*, through cylinder *F* to *P*, to *B*.

TRANSMITTER CIRCUIT, TELEPHONE.

The transmitter switch *W* being closed, the circuit is as follows:

From + side to third cell to transmitter *O*, through cylinder *F* to *P, B, H, L*, to - side of battery.

SECONDARY CIRCUIT, TELEPHONE.

The secondary of talking circuit is the same as the secondary of buzzer circuit.

The utilization of existing telegraph lines as a part or the whole of a circuit for buzzer and telephone working, at the same time not interfering with the use of the wire for Morse working, may be

effected by using condensers interposed between the line and the buzzer. (See fig. 63.)

The pulsations of the ordinary Morse sending are comparatively slow. The condensers, therefore, act as a very large resistance, and no appreciable effect will be noticed in the telegraph line.

The very rapid pulsations produced by the buzzer or transmitter, however, will permit of transmission from one buzzer to the other with little diminution of sound.

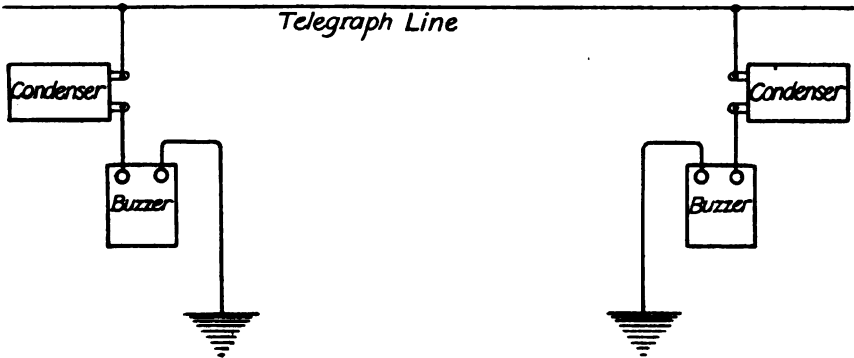

FIG. 63.

CAVALRY BUZZER.

This instrument is contained in a fiber box $2\frac{1}{8}$ by $5\frac{1}{4}$ by 7 inches. The box is divided into three compartments as shown in the photographs below. (Figs. 64 and 65.)

The whole is contained in a leather case which just fits the box. The transmitter and receiver, with connecting cords terminating in an ebonite plug fitted with three terminals, are contained in cylindrical leather case attached by a strap to the instrument case. The weight of the instrument complete is $5\frac{1}{2}$ pounds.

The ebonite plug with metal terminals fits into a recess in the side of the case as shown in photograph.

The buzzer is used as a call when it is desired to use the instrument as a telephone set.

For use on field lines with ground return, connect line to binding post *D L* and the ground connection to *E* (fig. 66).

For use on grounded telegraph lines, connect line to binding post *C L*, ground to *E*.

The circuits may be classified as follows:

Primary circuit.....	Telegraph.
Secondary circuit.....	Telegraph.
Transmitter circuit.....	Telephone.
Secondary circuit.....	Telephone.



FIG. 64.



FIG. 65.

When the instrument is not in use the primary circuit must be open to prevent polarization of the battery. The diagram shows this circuit open. By pressing "button" contact is made at B^1 and B^2 and broken at B^3 and B^4 and the primary circuit telegraph is closed.

PRIMARY CIRCUIT BUZZER.

From + side of battery to P , F , E , D , coils of interrupter, B^2 , B^4 , to - side of battery.

SECONDARY CIRCUIT BUZZER.

From S to E , earth, distant station, line $D L B^3$, B^1 , H , to S ; or from S to E , earth, distant station, line $C L$, C , $B^3 B$, H , to S .

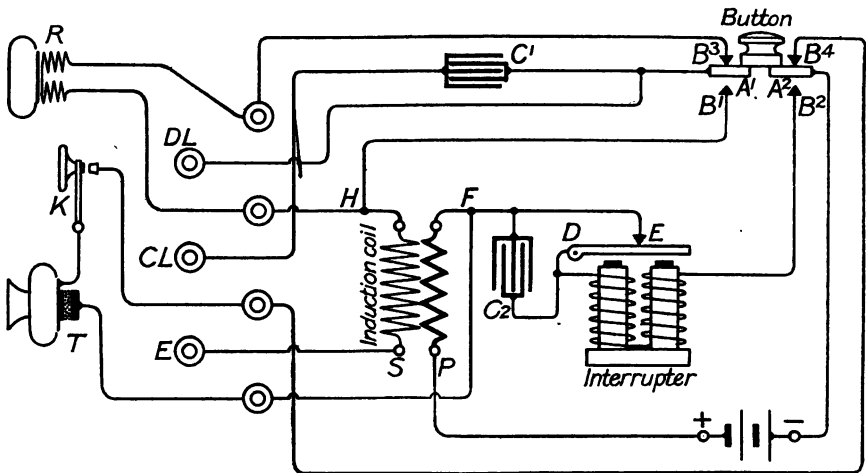

FIG. 66.

When keys A^1 and A^2 are depressed by button which protrudes through top of instrument case, the local or primary telegraph circuit is made as described above. Current from battery magnetizes iron core of electromagnetic interrupter, attracting spring armature D , breaking primary circuit at E . As soon as primary circuit is thus broken (the button still being depressed) the core of electromagnet becomes demagnetized and spring armature gains contact with E , again closing the circuit. This action, rapid making and breaking of primary circuit, causes a buzzing sound due to vibration of armature. The armature D being in series with the primary P of induction coil, the iron core of latter is also rapidly magnetized and demagnetized, due to vibration of armature, and a current is induced in the secondary S of induction coil, which reproduces in the distant receiver the buzzing noise. (Refer again to secondary circuit—telegraph.)

It will be noted that the buzzing sound is not heard in the receiver of sending instrument when both keys A^1 and A^2 are depressed by button, but if key A^2 only should be pressed down, the buzzing should also be heard in the receiver of sending instrument. In this manner the receiver and its circuit can be tested before placing instrument in line.

In order to prevent sparking at point of break in interrupter, a small condenser C^2 is bridged across the primary circuit telegraph, one terminal of condenser on each side of point of break.

TRANSMITTER CIRCUIT—TELEPHONE.

Depress switch K in transmitter, thus closing transmitter circuit, which is as follows:

From + side of battery of P , F , transmitter B^1 , A^2 , to — side of battery.

SECONDARY CIRCUIT—TELEPHONE.

Varying the current in transmitter circuit by talking into transmitter (see remarks under "Field-buzzer transmitter circuit") induces current in secondary of induction coil which flows through circuit described under secondary circuit—telegraph.

When button is pressed, A^1 is brought in contact with B^1 , before A^2 gains contact with B^2 . The reason for this is as follows:

When it is desired to leg this buzzer on a grounded telegraph line without interfering with telegraphic messages, connect line wire to binding post $C L$. If button is now pressed, the condenser is placed between the buzzer and telegraph line. By this arrangement there is no chance for telegraph line to ground through buzzer, the direct current operating telegraph line meeting in the condenser a resistance of infinite value, as previously explained.

CHAPTER V.—TELEPHONES.

THEORY OF THE TELEPHONE.

In the act of speaking the vocal cords cause air vibrations, which, falling upon the drum of the ear, are recognized by the auditory nerves as speech. If, instead of falling on the eardrum, these vibrations should fall upon a diaphragm which is capable of changing them into electrical vibrations, and there is some means of transmitting them along a line and again reproducing at the other end into similar air vibrations, we have the telephone. In order to understand the action of the telephone it is necessary to define lines of force and explain two simple laws of magnetic induction. Lines of force are imaginary lines which surround a magnet and indicate by their position and number the direction and strength of its action. The laws of magnetic induction referred to are: First, if a number of lines of force thread or pass through a coil of wire and this number is increased or diminished, a momentary current will flow in the coil; second, if a coil of wire be wound around a permanent steel magnet and a current of electricity be sent through the windings, it will, if in a certain direction, increase the strength of the permanent magnet, and if in the opposite direction will diminish its strength.

To understand how a telephone works, let us take the simplest case of two telephone receivers, *A* and *B*, connected to the line, as shown in figure 67.

The telephone receiver (a more detailed description of which will be given later) consists of a soft-iron diaphragm placed close to a permanent magnet. Around the diaphragm end of this magnet is wound a coil of fine insulated copper wire. The air vibrations, caused by the act of speaking, upon striking the iron diaphragm at *A* cause it to vibrate. The vibrations of this diaphragm produce changes in the number of lines of force which thread through the windings of the coil. These changes, according to the first law, produce a current in the winding which will be of greater or less strength and in opposite directions, following the vibrations of the diaphragm. This varying current proceeds along the line, and when it arrives at *B* will increase and diminish the strength of *B*'s magnet. The variation of the strength of *B*'s magnet will produce a varying pull on *B*'s diaphragm and cause it to vibrate in a manner similar to the

diaphragm of *A*. The vibration of the diaphragm at *B* is recognized as sound coming from *A*. The simple circuit shown in figure 67 would permit a person to talk or hear, as the case may be. The first modification of this circuit (fig. 68) is to introduce two telephone receivers at the point *A* and two at the point *B*, all being in series, one serving as the transmitting and the other as the receiving instrument at each point.

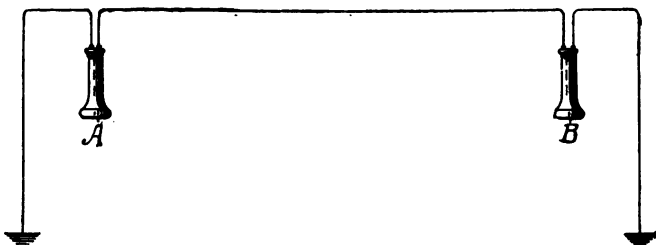

FIG. 67.

For certain reasons this type of receiver just described does not make a good transmitter, and in practice is replaced by a battery transmitter.

A complete local battery telephone instrument consists of a receiver, local battery transmitter, induction coil, magneto generator, call bell, and certain switching devices which are contained in the magneto-generator box.

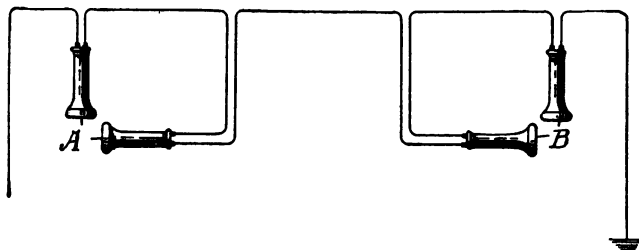

FIG. 68.

A complete common battery instrument consists of a receiver, transmitter, induction coil, condenser, call bell, and switch hook.

LOCAL BATTERY TRANSMISSION.

The battery transmitter depends for its action on the fact that a varying pressure changes the resistance of carbon. The transmitter consists of a number of carbon particles or granules in a proper receptacle with a means of varying the pressure upon the granules in circuit with a battery and the coarse-wire winding of an induction coil. The induction coil consists of a bundle of soft iron wires, sur-

rounded by two windings of insulated copper wire, one being of coarse wire, with few turns and low resistance, called the "primary," and the other of fine wire, with a large number of turns and higher resistance, called the "secondary." The relative position of these various parts of a local battery instrument is indicated in figure 69, in which *T* is the transmitter that contains the carbon granules through which the current from battery *B* flows. *T* also contains a diaphragm which presses on the carbon granules, or is so connected with them as to vary the pressure between the particles as the sound waves fall on it. *P* is the coarse and *S* the fine wire winding of the induction coil, which is connected to the receiver *R* and the line. The local battery circuit includes *B*, *P*, *H*, and *T*. As the air vibrations fall on the diaphragm at *T* they produce a change in the resistance between the carbon particles in contact with it. This change of resistance

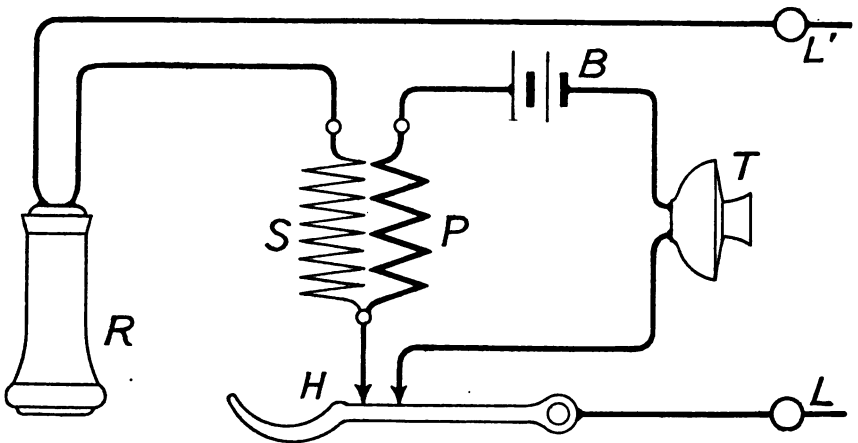

FIG. 69.

causes the current flowing in the coarse-wire coil to fluctuate, thereby inducing a fluctuating current in the fine-wire coil, which goes to the line and receiver and reproduces speech, as has been explained before.

COMMON BATTERY TRANSMISSION.

The common battery telephone operates like the local battery in its essential details. The principal point of difference lies in the fact that in common battery operation the current which flows through the transmitter is furnished by battery installed at the central exchange in place of local battery installed in the instrument, as in the case of the local battery telephone. In the common battery telephone battery is supplied over the same wires that are used for transmitting speech. Figure 70 shows the essential parts of the common battery instrument. The induction coil for this type of

instrument is usually provided with primary and secondary windings having more nearly the same number of turns and resistance than is found in the local battery instrument. The receiver and transmitter are practically identical with similar parts of the local battery telephone. The operation of a typical set is as follows (referring to fig. 70) :

Direct current from the positive side of the battery at the central exchange enters the instrument over the line L^2 , passes through the hook H , primary winding P of the induction coil, transmitter T , and leaves the instrument by the line L^1 . If now the transmitter T is spoken into, the diaphragm, vibrating, produces a change in the resistance between the carbon particles placed near it. This varying resistance causes a corresponding variation in the current flowing, which is received at the distant station as speech. This varying current in the winding P acting upon the winding S , which is placed upon the same core, induces a current in the receiver circuit composed of the receiver R and the winding S . In the case of receiving from a distant station the voice current may be considered to follow the same course as that taken by the battery current. This current, however, is variable, and in passing through the winding P of the induction coil induces a current in the receiver circuit.

In the normal condition of the instrument when not in use the receiver R draws down the hook H , opening the contact, thus preventing the flow of battery when the instrument is not in use. In this position of the hook the bells B may be actuated by an alternating current from the central exchange which passes through the bells B and the condenser C in series. The condenser C operates to prevent the flow of the battery current through the bells, but does not prevent the passage of the alternating current.

Owing to the fact that the common battery instrument depends for its operation on direct current in the line, the range of such operation is necessarily limited by the resistance of the line circuit. When the resistance of the line becomes so high as to cut down the current materially the efficiency of the circuit is correspondingly decreased, so that when a common battery telephone is intended to operate over a considerable distance repeating coils are installed to overcome this difficulty.

MAGNETO.

The magneto generator is largely used for producing the calling current. It is the simplest form of electric dynamo and consists of an armature wound with many turns of fine wire so mounted as to enable it to be rapidly revolved between the poles of a permanent horseshoe magnet. Its theory depends upon the principle that if the number of lines of force passing through a closed coil be varied a

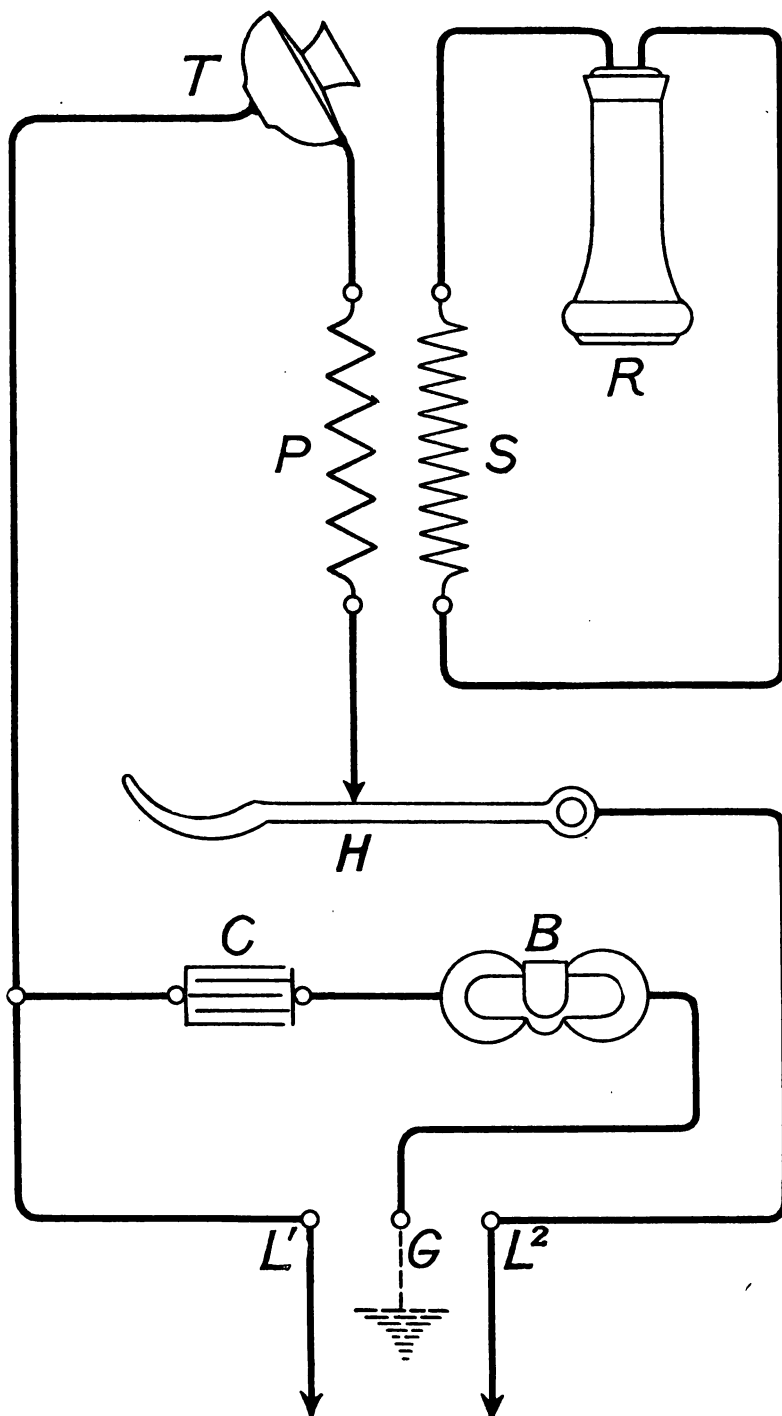

FIG. 70.—Common battery telephone circuit.

difference of potential will be developed between the terminals of this coil, and if an external circuit be connected electric currents will flow, the direction of which will depend upon the relative direction of the lines of force and the movement of the coil. In figure 71 is shown a simple loop of wire *a*, which may be revolved about a horizontal axis in the field of force produced by a permanent magnet. The horizontal arrows show the direction of the lines of force set up by the magnet which pass through the loop. If now the loop be revolved in the direction of the curved arrow, new lines of force will pass through it in the horizontal position as it approaches the position shown by the full line, and it will include an increasing number of these lines. The current induced in the coil will then be in the direction indicated by the arrows *X* and will so continue until the loop is in the vertical position. In the vertical position the lines of force are parallel to the movement of the coil, and the current and voltage are, therefore, zero. From this position the number of lines passing through the loop begins to decrease, and the current, therefore, takes the opposite direction as indicated by the arrow *Z*. The current increases in strength in this new direction until the coil is again in the horizontal position. At this point the rate at which the number of lines through the coil is changing is greatest, and the current is, therefore, maximum. As the coil passes through the horizontal position the number of lines passing through begins to increase again. This does not cause a change in the direction of the current, because the direction of the lines of force through the coil also changes at the same time. The same cycle takes place during the next half turn, when the coil is again in its original position. It will thus be seen that the current generated is alternating, changing its direction twice during each revolution, and if an external circuit be connected to the terminals of the coil an alternating current will be set up therein.

The magneto generators used by the Signal Corps are provided with an automatic device which either short-circuits the armature or opens the armature circuit when the armature is at rest, the former being furnished for use in series telephones to remove the armature resistance from the circuit by providing an alternate path of practically no resistance. When the magneto is used in bridging circuits this device opens the armature circuit when the generator is not in use.

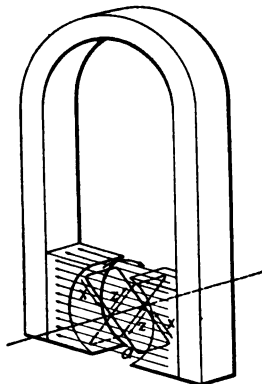

FIG. 71.—Principle of the magneto generator.

At the usual rate of turning the magneto generator by hand the voltage will be about 65 to 75 and the frequency about 15 complete cycles, or double alternations, per second.

In figure 72, *A* shows the generator armature on which are wound the many turns of fine wire which are revolved in the magnetic field referred to above. It will be noted that this armature is made of a large number of thin stamped metal pieces which are assembled on

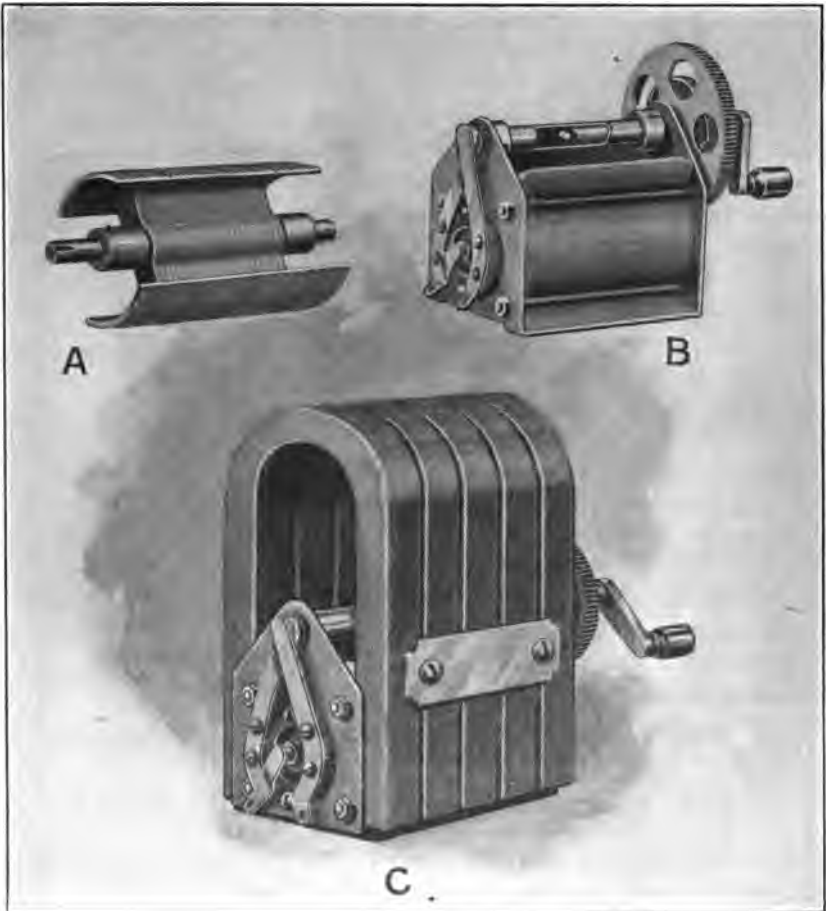

FIG. 72.—Magneto generator.

the armature shaft as shown. In part *B* of the above figure the generator armature, wound, has been placed within the generator frame. A device for opening the generator circuit is shown in the figure mounted in place on the end of the generator frame. On the other end a gear wheel and crank for revolving the armature are shown. *C* shows a complete generator of the 5-bar type with the horseshoe magnet in place.

Generators used by the Signal Corps are provided with 3, 4, or 5 bars, depending upon the class of service in which they are to be used.

RECEIVER.

A receiver of the type now used almost exclusively in the Signal Corps is shown in figure 73. It consists of a U-shaped permanent magnet *m*, to the ends of which are fastened soft-iron pole pieces *p p*. Over each pole piece is a coil of fine wire wound on a bobbin with nonmagnetic metal heads. These coils are connected in series in such a manner as to make the front end of one the north pole and the similar end of the other the south pole when current flows through both coils in a certain direction. The combined resistance of these coils connected in series is about 80 ohms. The pole pieces pass through the bottom of a metal cup *C*, which is thus secured firmly in

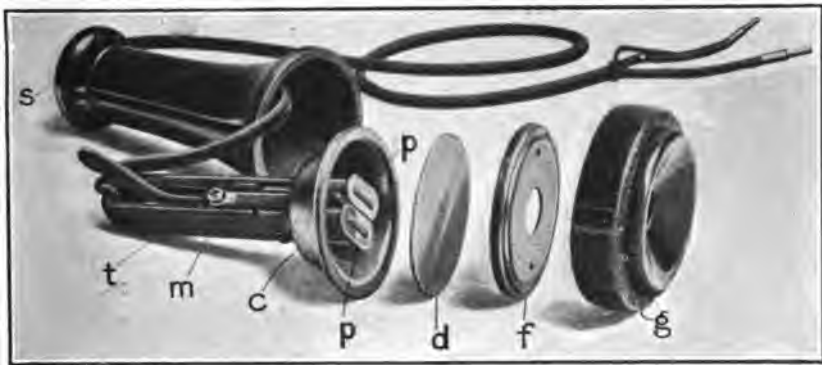

FIG. 73.—Hand receiver.

place. The diaphragm *d*, of soft iron, tinned or enameled, rests on the rim of this cup. A clamping ring *f* screws onto the metal cup *C*, thus holding the diaphragm *d* firmly in place. The receiver cords are connected to terminals *t*, a strain cord being attached to the loop of the magnet to provide against injury to the cord conductors. As thus assembled the receiver is operative and may be so used in case of accident to the containing shell and cap. This shell *S* slips over the working parts of the receiver and is held in place by the ear piece *g*, which screws onto the shell. The separation of the diaphragm from the pole piece varies with the different types of receivers, the usual separation being about 0.014 inch.

The operation of the receiver is as follows:

The pole pieces *p p*, being attached to the ends of the permanent magnet *m*, have one a north and the other a south polarity and the magnetic circuit is completed from one pole to the other through the soft iron diaphragm *d*, which is, therefore, drawn toward the poles and

held in constant tension. If now a current flows through the coils in such a direction that the lines of force due to it coincide with those of the permanent magnet, the diaphragm will be pulled closer to the pole pieces, due to the increased strength of the magnetic field. If the current flows in the opposite direction, the strength of the magnetic field, due to the permanent magnet, will be reduced and the diaphragm will spring farther from the poles. It will thus be seen that whether the lines of force due to the current in the coils assist or oppose those due to the permanent magnet, a varying pull is produced on the diaphragm that causes vibrations in the latter in unison with the changes in current. The movement of the diaphragm will thus set up vibrations in the surrounding air which may be perceived as sound.

TRANSMITTER.

The operation of the transmitter depends on the fact that the electrical resistance between two or more bodies, either in light or loose

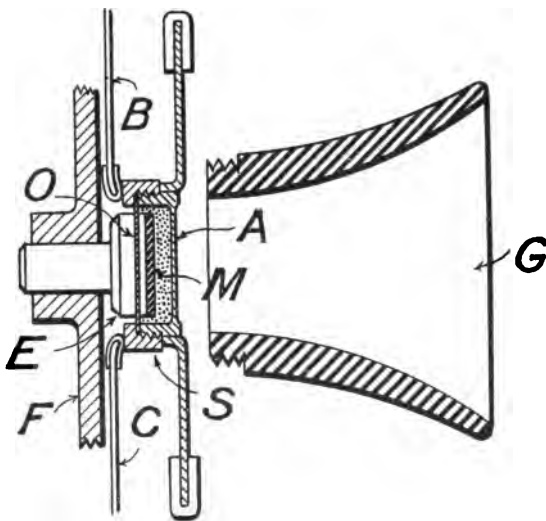

FIG. 74.—Telephone transmitter.

contact, varies with changes in the pressure between the bodies. The change in resistance is due to variation in the area of contact surface between the granules and electrodes and not to compression of the carbon granules themselves. In general, the transmitters used by the Signal Corps depend on this principle. A typical transmitter is shown in figure 74. A metal cup, *A*, forms the

front electrode and is attached to the diaphragm for sending. The rear electrode is held rigidly in a metal bridge piece, *F*, which is in turn fastened to the frame which supports the mouthpiece *G*, and the remainder of the transmitter. This rear electrode consists of a hard polished carbon button, *M*, secured to a brass button between two parts of which is clamped a mica ring or diaphragm, *O*, the outer edge of which is clamped against the front electrode, *A*, by means of a metal ring, *S*, which screws over *A*. The space between the front and rear electrodes is partly filled with hard granular carbon of

uniform size. Two dampening springs, *B* and *C*, are provided to prevent vibration of the diaphragm at its natural period.

The operation of the transmitter is as follows:

Current from a battery passes from one terminal, *E*, to the carbon electrode through the granular carbon to the metal cup which forms the other electrode. If the transmitter now be spoken into, the diaphragm and cup vibrate in unison with the sound waves produced in the air, thus causing the pressure between the front and rear electrodes on the granular carbon to vary and thus change the resistance of the transmitter. Therefore, variations in the current are set up which correspond exactly with the voice vibrations which reach the transmitter diaphragm.

RINGER.

The magneto generator is commonly used in connection with a polarized bell or ringer, as it is usually called, by means of which audible signals indicate the incoming calls on the telephone instruments. The usual form of this piece of apparatus is shown in figure 75. In this figure *c c* represents soft iron cores upon which are wound coils of fine wire connected in series with the line wires *l l'*. *N S* is a permanent magnet, and *A* a soft-iron armature pivoted at its center. A slender rod terminating in a small metal ball is attached to the center of the armature. When no current is flowing through the coil, the permanent magnet *N S* causes the upper ends of the cores to be south poles and the opposite ends to be north poles. In this condition the armature will be attracted by both

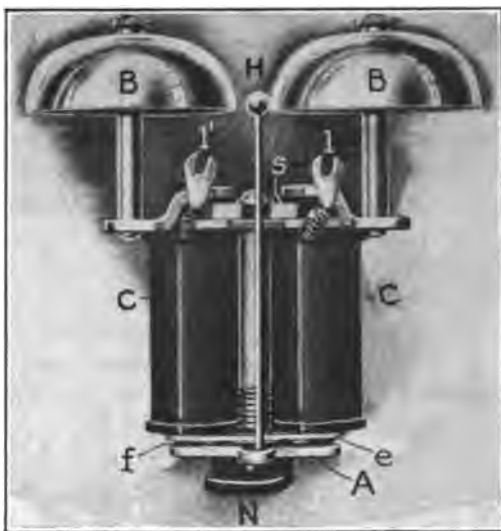

FIG. 75.—Telephone ringer.

cores and will rest against one or the other as may chance to happen. If now current passes through the coils in series in such direction as to increase the strength of the north pole *f*, and to make *e* south pole or weaker north pole, then *f* will attract the end of the armature opposite it, while *e* will repel this end of the armature or attract it with smaller force. If the current is now reversed in direction so that *f* becomes a south pole or a weaker north pole and *e* a stronger north pole, the

action will be reversed. e will attract its end of the armature and f repel its end or attract it with smaller force. With the ringer connected to the magneto generator as shown in this figure the armature will vibrate between the two gongs with the same frequency as the current produced by the hand generator, and a practically continuous ringing sound will result. Practically all of the ringers used by the Signal Corps are wound to a resistance of 1,000 ohms.

A complete ringer of the type largely used in Signal Corps instruments is shown in figure 75.

TYPES OF INSTRUMENTS.

The principles upon which depends the operation of the various parts of the telephones have been explained in the preceding pages. The complete circuits of the instruments of the various types used by the Signal Corps will now be considered, and it will be assumed that the operation of the various parts as explained above is understood, and will not be discussed further. The instruments herein described have been selected as being typical of those now in use by the Signal Corps. It is not possible to describe all of the types of each class of instruments in the space available. It is thought, however, that familiarity with the ones shown will enable such other types as may be met with in practice to be easily understood. Frequent reference will be made hereafter to the standard bridging circuit for local battery telephones. Such a circuit is shown in figure 76. The various circuits in this figure may be traced as follows:

1. Incoming signals from L' to ringer B through closed contact at C to hook switch and out over line L . The hook switch is shown in its normal position when the hand receiver is in place. This is the position for receiving incoming signals or for calling other stations.

2. The ringing circuit, starting from one pole of the generator G , passes to the line L' through the distant ringer, back to the line L , to the hook switch H , returning to the opposite pole of the generator.

3. Assuming now that the receiver has been removed from the hook switch H , the upper contact will be closed and the lower opened, thus removing the ringer and generator from the circuit.

The local battery circuit is now closed from the battery to the transmitter, primary of induction coil, hook switch H , and return to battery.

4. The receiving circuit passes from line L' through receiver R , secondary S of induction coil, hook switch H , to line L .

In the circuit shown the ringer and generator are removed from the circuit during receiving or transmitting. It is considered equally good practice, however, to connect these permanently in parallel be-

tween the lines L' and L , the paths of the electrical currents not being altered by these connections. This second arrangement is shown in B of the same figure.

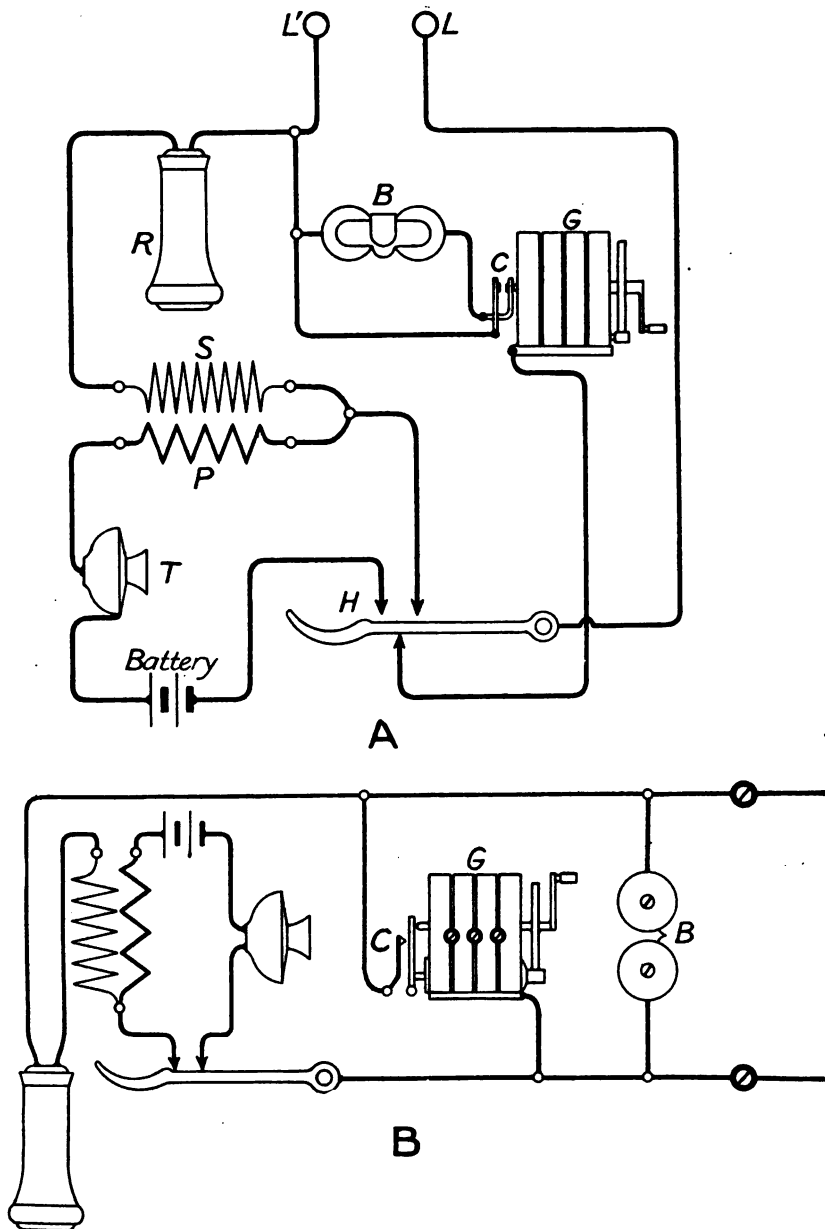

FIG. 76.—Circuits of a Signal Corps bridging type telephone.

FIELD TELEPHONE, MODEL 1910.

The field telephone, model 1910, does not differ materially from the 1904 and 1905 types previously issued. The circuits are those of

the standard local battery bridging telephone, the hook switch being replaced by a push-button switch in the handle of the hand set operated by the thumb or finger. The circuits of this telephone are shown in diagram in figure 77.

It will be noted from this figure that the switch is used to close the local battery circuit and connect the receiver and secondary of induction coil to the line when the telephone is in use and disconnect these when not in use. The hand-set circuit is shown in figure 77.

The transmitter and receiver are standard types provided with a special rigid metal mounting, usually of aluminum, to reduce weight;

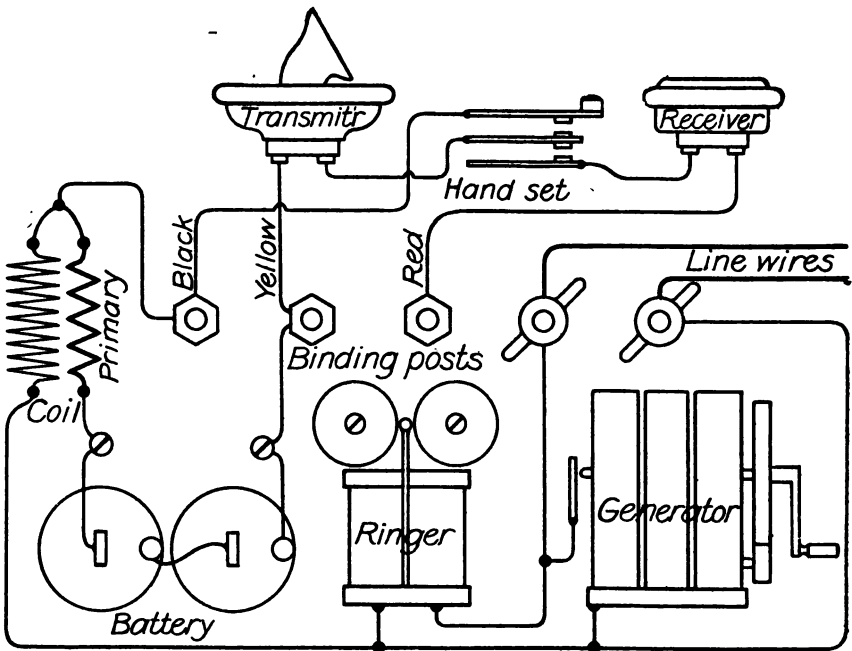

FIG. 77.—Circuits of field telephone, model 1910.

nonrusting metal and hard rubber insulation with water-proof construction being used throughout. Magneto generators of the three-bar type are used, these being ample for the short lines and small number of instruments used in field service. The generator handle is removed when the instrument is not in use. A small wrench is also furnished with each set, which should be used to keep all nuts tightly in place. Instructions for operation and field repairs are placed in the cover of the instrument. The assembled instrument is shown in figure 78a. A rear view of this instrument is shown in figure 78b.

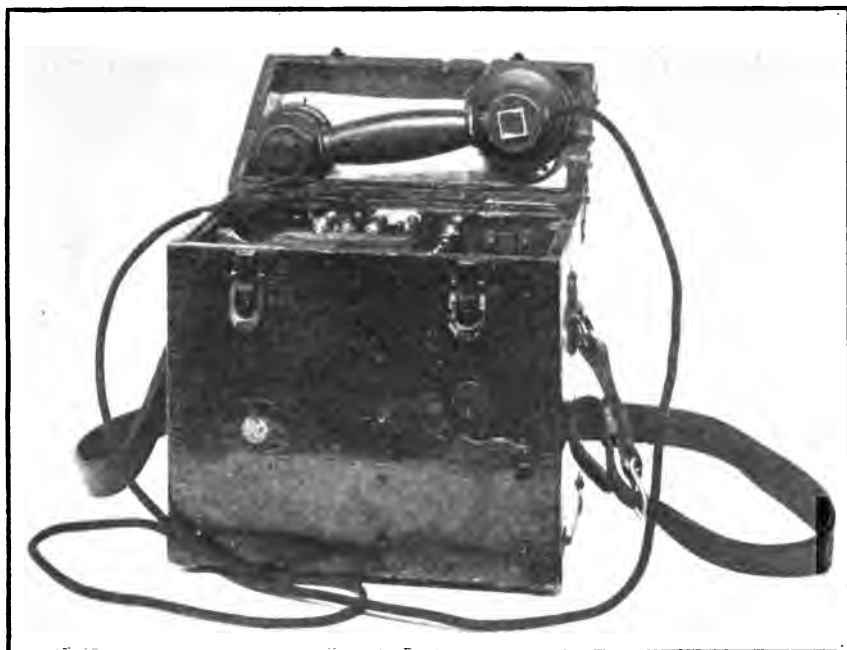

FIG. 78a.—Signal Corps field telephone, model 1910.



FIELD ARTILLERY TELEPHONE, MODEL 1910.

The field artillery telephone, model 1910, is a local battery instrument, designed especially for use by the field artillery.

The principal parts of this telephone are mounted on a fiber base and connected electrically by copper strips countersunk on the reverse side of the base plate.

The base plate with assembled parts mounted thereon is secured in a case by three attaching bolts provided with holding nuts and washers.

Figure 80 shows the circuits of this instrument. The calling device consists of a vibrator tongue mounted on an armature at one end of the induction coil, and is operated by a push button. There is a small adjusting screw bearing upon the vibrator tongue by which the vibrator can be regulated.

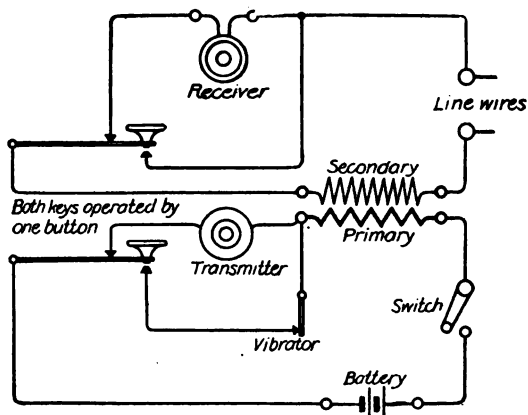

FIG. 80.

When the telephone is in use the transmitter must be swung up into place, thereby automatically closing battery circuit; after use, the transmitter must be swung back to traveling position, which automatically opens the switch.

This arrangement prevents packing up the instrument after use without opening the battery circuit. The battery employed is composed of two small tubular dry cells of commercial type, superimposed and covered by a stiff paper cover. This cartridge battery is held in place by sections of brass tubing and held at the top and bottom by a cap and spiral spring respectively. The battery may be readily removed by first removing the brass cap.

The containing case is made of aluminum and covered with fair leather riveted to the metal.

This instrument weighs about 6 pounds and measures $3\frac{1}{4}$ inches by 7 inches by 8 inches.

To use this instrument the case is opened and plug connection made. The transmitter is raised and receiver removed from the case. The case is then closed and the receiver is attached to the head of the operator by an elastic band and the telephone slung about the neck.

LOCAL BATTERY WALL TELEPHONE.

The circuits of the local battery wall telephone of the Sumter Telephone Manufacturing Company's make are shown in figure 81.

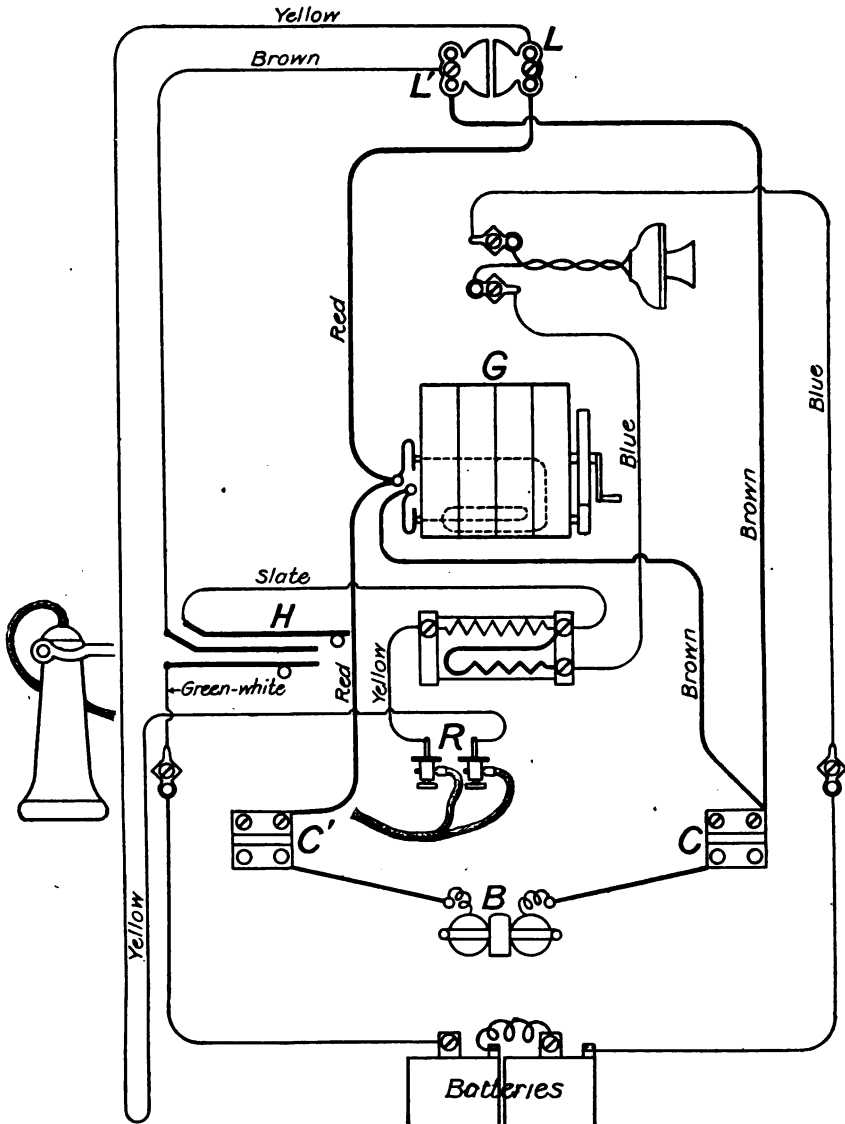

FIG. 81.—Circuit, local battery telephone, Sumter type.

This figure indicates the actual wiring of the instrument and the parts correctly placed with relation to each other as they are mounted in the instrument. The circuits of this instrument may be traced as follows:

1. Incoming signals enter at line L' , pass to hinge C , to bell B , to hinge C' , and return to line L . The hook switch is shown in its normal position with the hand receiver in place, all contacts being open.

2. Outgoing signals pass from one pole of the generator G to the line L through the distant instrument and return on L' to hinge C



FIG. 82.—Wall telephone, Sumter type.

to the opposite pole of the generator G . In this instrument the bells B are permanently connected between the lines L and L' , as is also the generator G . The latter, however, by means of its switching device, is open circuited when not in operation.

3. The local battery and transmitter circuits pass from the battery through the transmitter and the coarse-wire winding of the induction coil through the hook switch H , which now has all contacts closed, to the opposite pole of the battery. The receiving circuit



FIG. 83.—Wall telephone, Sumter type.

passes from L' to the hook switch H through the fine-wire winding of the induction coil, through the receiver R to the line L .

In figures 82 and 83 is shown the complete instrument to which the wiring diagram above refers.

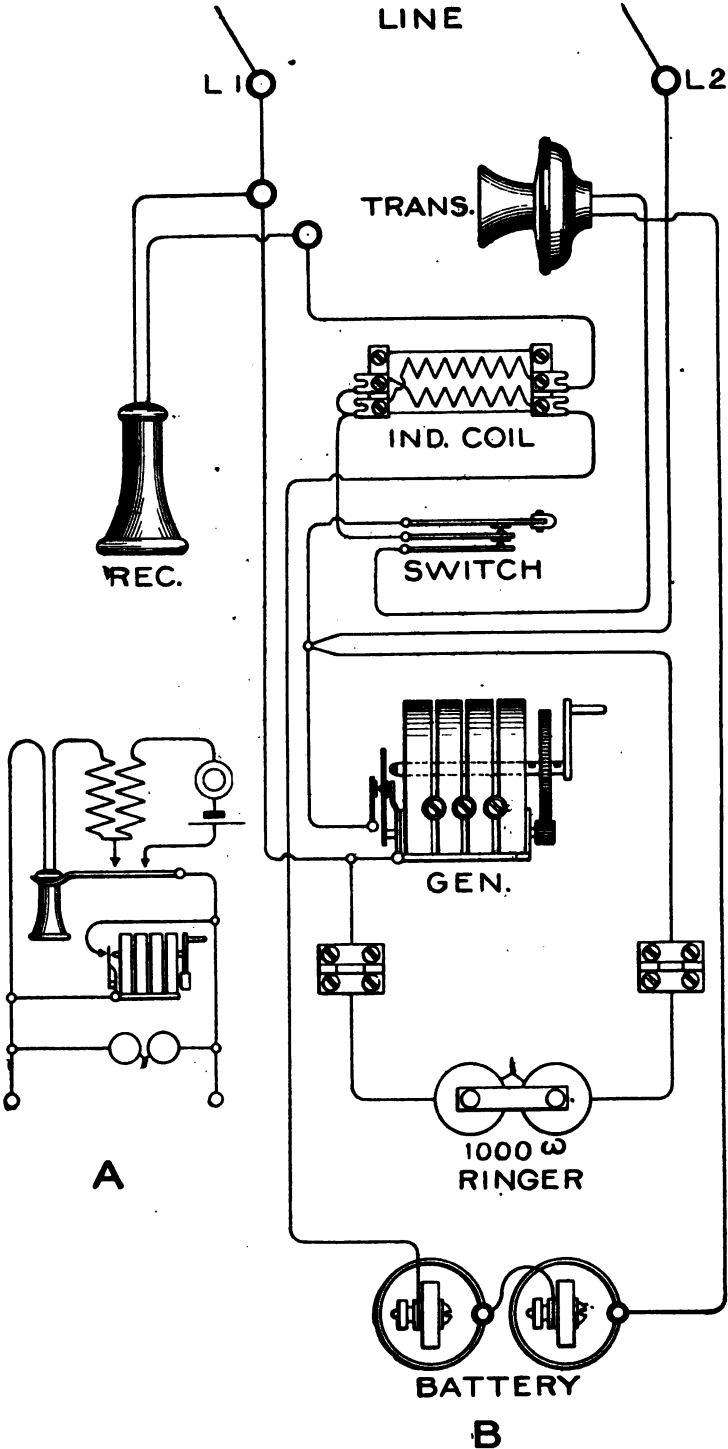

FIG. 84.—Circuit, local battery wall telephone, Dean type.

The wiring of the Dean local battery wall telephone, which is furnished by the Signal Corps, is shown in figure 84. In this figure, *A* shows a simplified circuit, and *B* the wiring as actually found in the instrument with the parts correctly located with respect to each other.

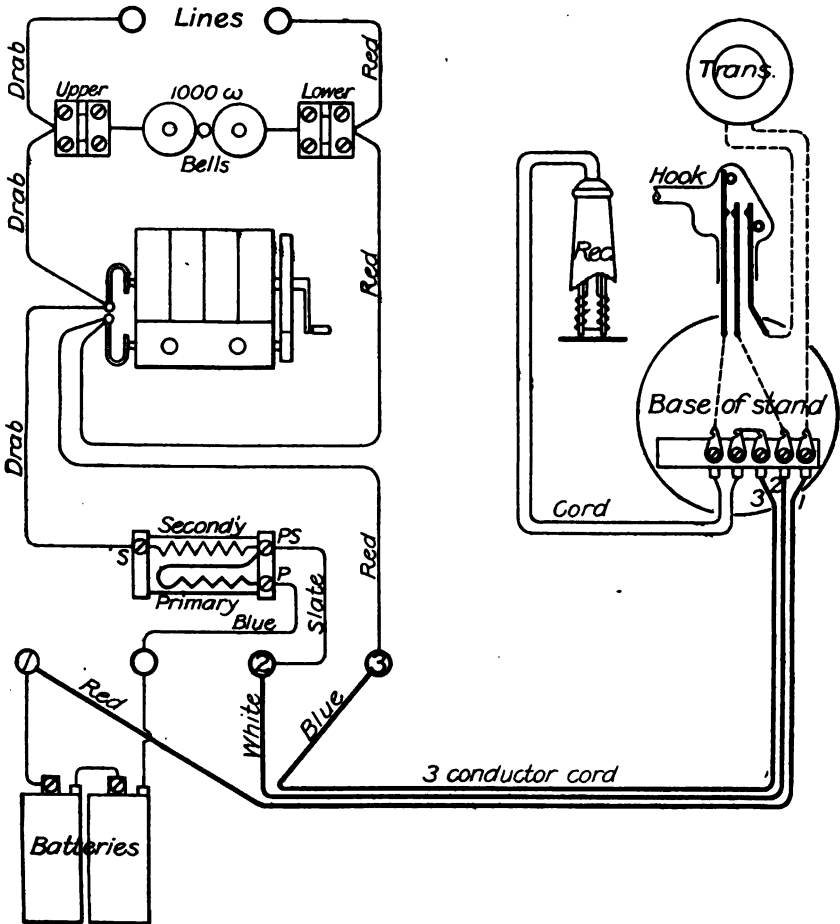

FIG. 85.—Circuit, local battery desk set, Sumter type.

LOCAL BATTERY DESK SET.

In figure 85 is shown circuits of the local battery desk telephone of the Sumter make, as furnished to the Signal Corps. The usual bridging circuit is used. The diagram shows the actual wiring as it is found in the instrument, and the various parts are shown correctly placed with respect to each other.

COMMON BATTERY TELEPHONE.

In general it may be said that the parts used in the common battery wall telephones are similar to those used in the local battery.

It will usually be found that the primary of the induction coil used in the common battery instruments is of higher resistance, and that the ratio between the primary and secondary windings of the induction coil are quite different. A common battery wall telephone of the Sumter make is shown in figure 86. *A* shows the wiring of

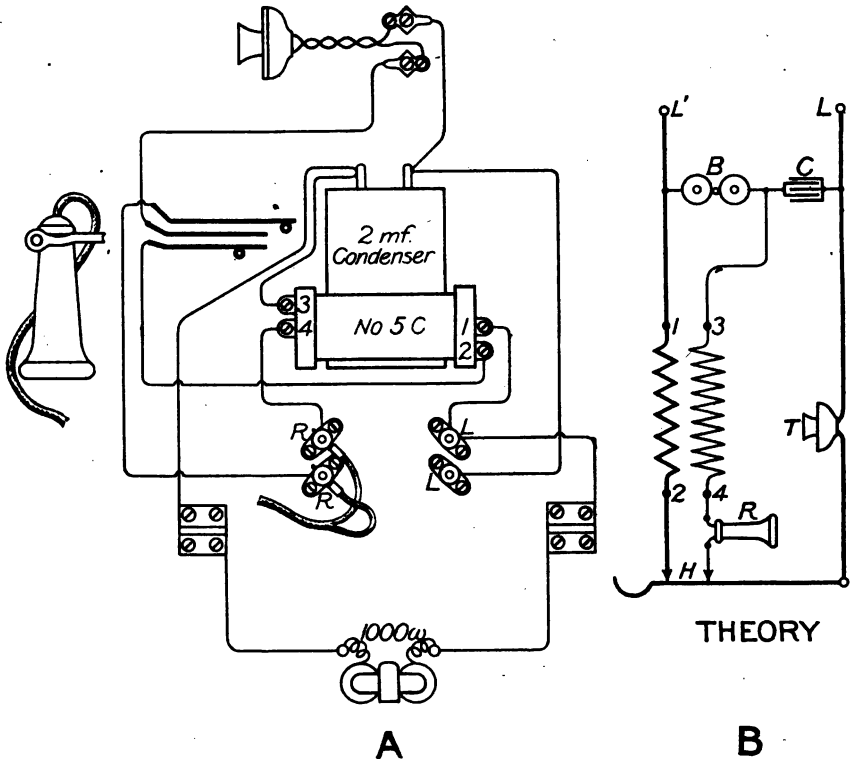

FIG. 86.—Circuits, common battery wall set, Sumter type.

the instrument and the parts with correct relation to each other, and *B* a simplified circuit diagram of the instrument. The operation of the instrument is as follows:

Assuming that the receiver is in place on the hook switch, the incoming ringing current will pass from the line *L'* through the bells *B*, condenser *C*, to the line *L*, ringing the bells *B*. The hand receiver being removed from the hook switch, the contacts at *H* are closed. In this condition the battery from the central exchange passes from *L'* through the coarse-wire winding of the induction coil through the transmitter to the line *L*. Battery also passes from the bells *B*, sec-

ondary or fine-wire winding of the induction coil, receiver R , transmitter T , to the line L . The resistance of this second path is very much greater than that of the first path, so that the current flowing in this high resistance path may be considered negligible. If now the transmitter be spoken into the current flowing through the transmitter will vary by reason of the varying resistance of the transmitter, caused by varying pressure between the carbon granules. These fluctuations in current flowing affect the distant receiver and reproduce the speech at T . Incoming speech follows the same circuit as that taken by the battery from the central exchange. This voice current, however, being alternating in character, induces a current in the fine-wire winding of the induction coil. This current passes through receiver R , hook switch, transmitter T , and condenser C , thus reproducing in the receiver R the sounds impressed on some distant transmitter. The condenser also serves to strengthen the effect of the induced current in R by reason of the varying potential across its terminals.

In figure 87 is shown a common battery desk set of the Sumter Company's make as furnished to the Signal Corps. In this figure A represents the actual wiring and arrangement of the parts and B the elementary diagram. It will be noted that this corresponds exactly to the circuits of the wall telephone and the description given for the operation of the set mentioned above (wall telephone) applies equally as well to this.

In figure 70 are shown the circuits of the common battery telephone furnished the Signal Corps by the North Electric Company. The operation of this set differs somewhat from the Sumter, described above, and is as follows:

With the hand receiver removed from the hook switch, the contact at H being closed, current flowing from the battery at the central exchange passes over the line L' to transmitter T , coarse-wire winding of the induction coil, hook switch H , to the line L^2 . This current flowing through the transmitter T is modified by speaking into the transmitter in the usual way. Incoming voice currents follow the same path as that taken by the battery from the central exchange, these being alternating in character, and as they pass through the winding P , induce currents in the winding S , which pass through the receiver R and return to the coil S , thus reproducing speech in R . It will be noted that this receiving current has no direct connection with the remainder of the instrument. This differs in this respect from the one described above.

Incoming signals are received in the following manner:

Entering by the line L' , pass through the condenser C , ringer B , and binding post G , which in the Signal Corps instrument is permanently connected to the line L^2 . The hand receiver being in place,

the contact at the point *H* is opened. The condenser *C* is installed to prevent the flow of current from the central battery through the

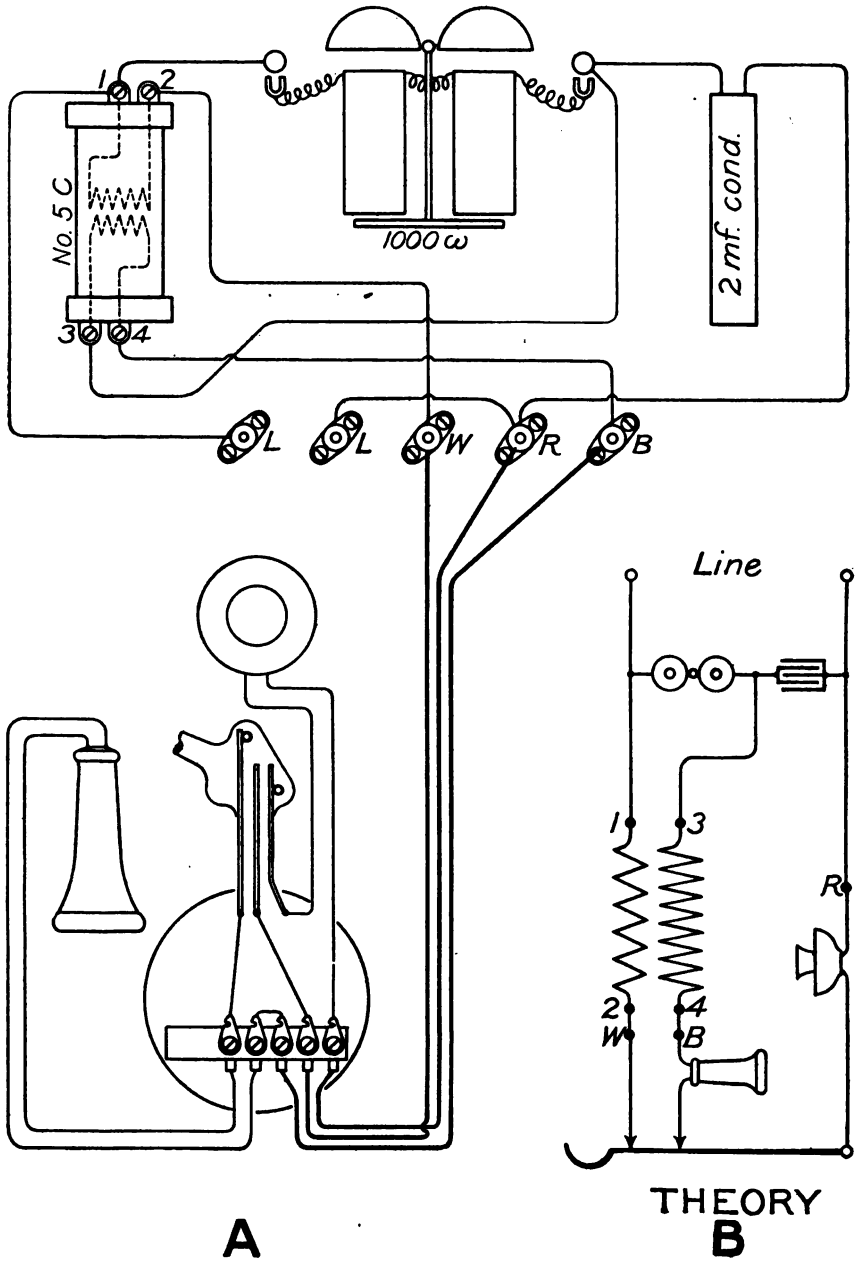

FIG. 87.—Circuits, common battery desk set, Sumter type.

bells *B* at all times. This condenser does not affect the passage of the alternating currents such as are produced by magneto generators.

In figure 88 is shown the circuit of the above figure as installed in a common battery wall telephone furnished the Signal Corps. Figure 89 shows the circuits as furnished in the desk set type of the same instrument.

THE CUT-IN TELEPHONE.

The cut-in telephone, model 1905, as shown in figure 90, is used for cutting in on an ordinary telegraph line to talk with repair par-

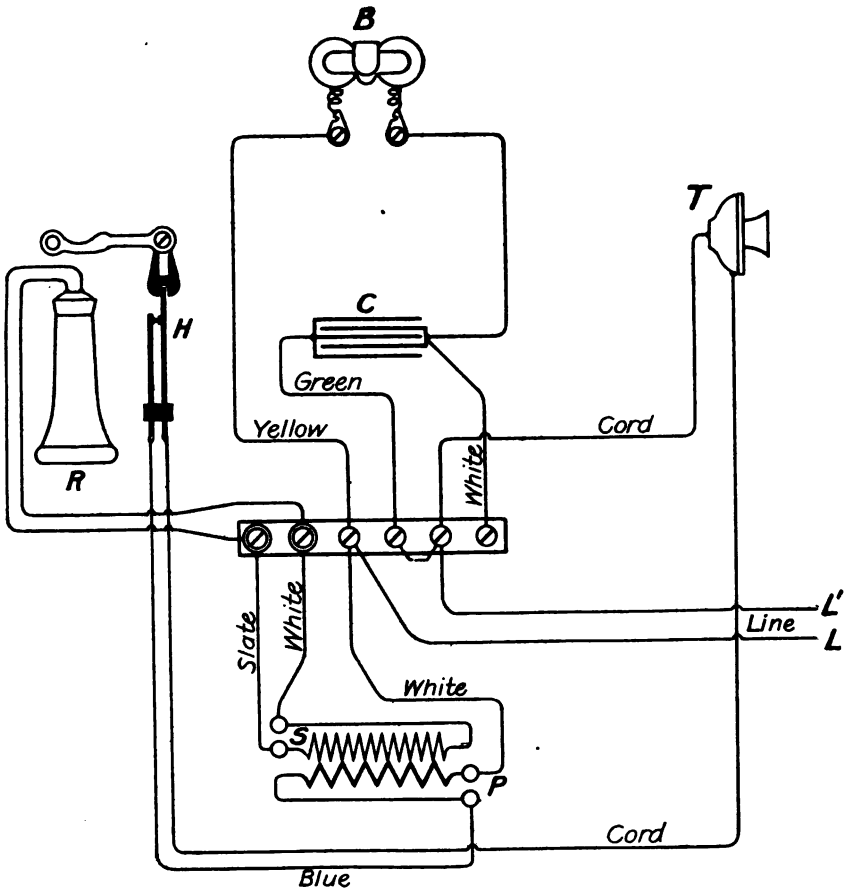

FIG. 88.—Circuit, common battery wall telephone, North type.

ties without interrupting telegraphic communication, and for outpost service in the vicinity of a telegraph line. The simplified diagram of the wiring of this instrument is shown in figure 91. If a telephone receiver is inserted in the ordinary telegraph circuit the make and break of the current will cause a series of snappings of the diaphragm, which would completely obscure any talk; if, however, this snapping of the diaphragm is eliminated, talk coming over the line can be heard in the receiver. To do this the rise and fall of the current, due to the

opening and closing of the Morse circuit, must be regulated with respect to the receiver so that no audible indication of it can be heard. This is done by inserting a coil of high self-induction between the telegraph instrument and the telephone. This coil so regulates the Morse current with respect to the receiver that when the telephone is joined through a condenser to the line no sound of the telegraph instruments can be heard, but telephonic speech coming over the line will be audible. The condenser, in addition to helping regulate the Morse current, prevents the telegraph line from being grounded through the telephone. The hardwood box contains a

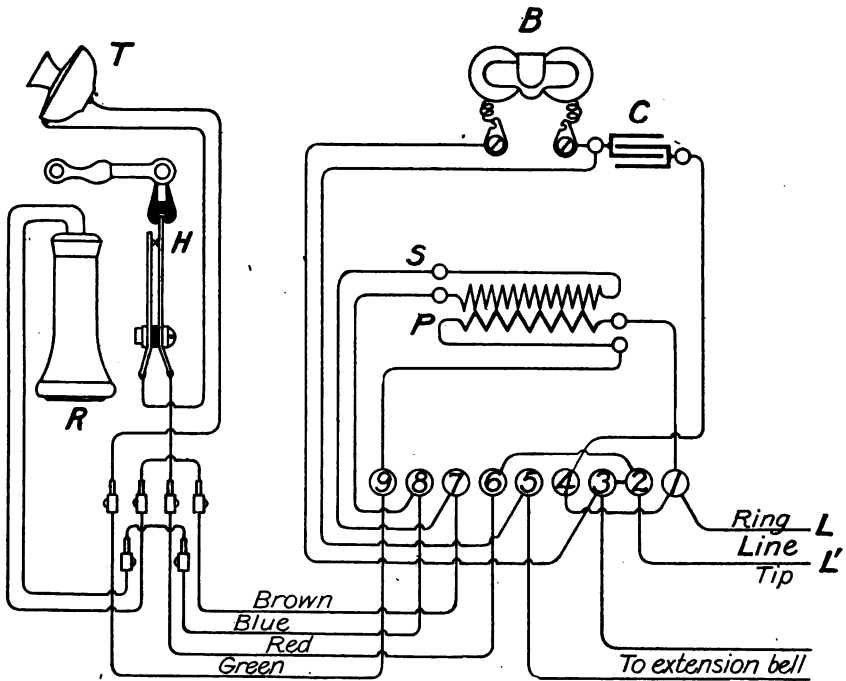

FIG. 89.—Circuit, common battery desk telephone, North type.

hand set combining the receiver and transmitter, the circuit of the latter being controlled by a spring switch in the handle. The box also contains the calling device, the choke coil, condenser, and the cells of dry battery. The choke coil, whose core consists of a number of soft-iron wires projecting a couple of inches beyond the ends, is wound to 4 ohms, so that when the serrated metal plate is scratched by the spring controlled by the button on the left the discharge current will be of such volume as to produce a loud note in the receiver at the distant station. When the two stations that are communicating with each other are between two telegraph stations one binding post on the top of each box is connected to the telegraph line and the

other grounded. When a telegraph station intervenes between the two telephone stations the telegraph set must be bridged by a condenser.

INSPECTION OF ELECTRICAL INSTALLATIONS OF THE SIGNAL CORPS.

It is required that inspections of the electrical installations of the Signal Corps be made at stated intervals. In the case of coast artillery posts these inspections are made annually, and for all other

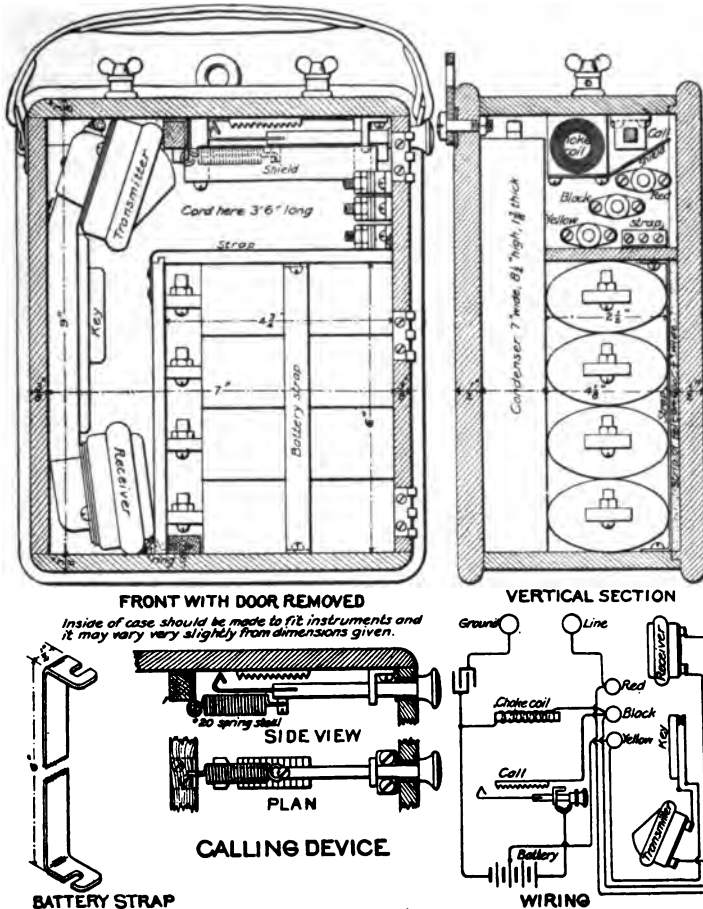

FIG. 90.

military posts semiannually. The objects of such inspections are to ascertain that the equipment and connections are in conformity with War Department orders; that they are efficiently maintained and properly operated; to observe defects or deterioration of apparatus or material; to report as to types and location of instruments, and to make recommendations as to possible improvements in material, instruments, or methods of installation.

The inspector on such occasions is the representative of the Signal Corps, and should endeavor to make the report as complete and comprehensive as possible. It is also intended to use the information

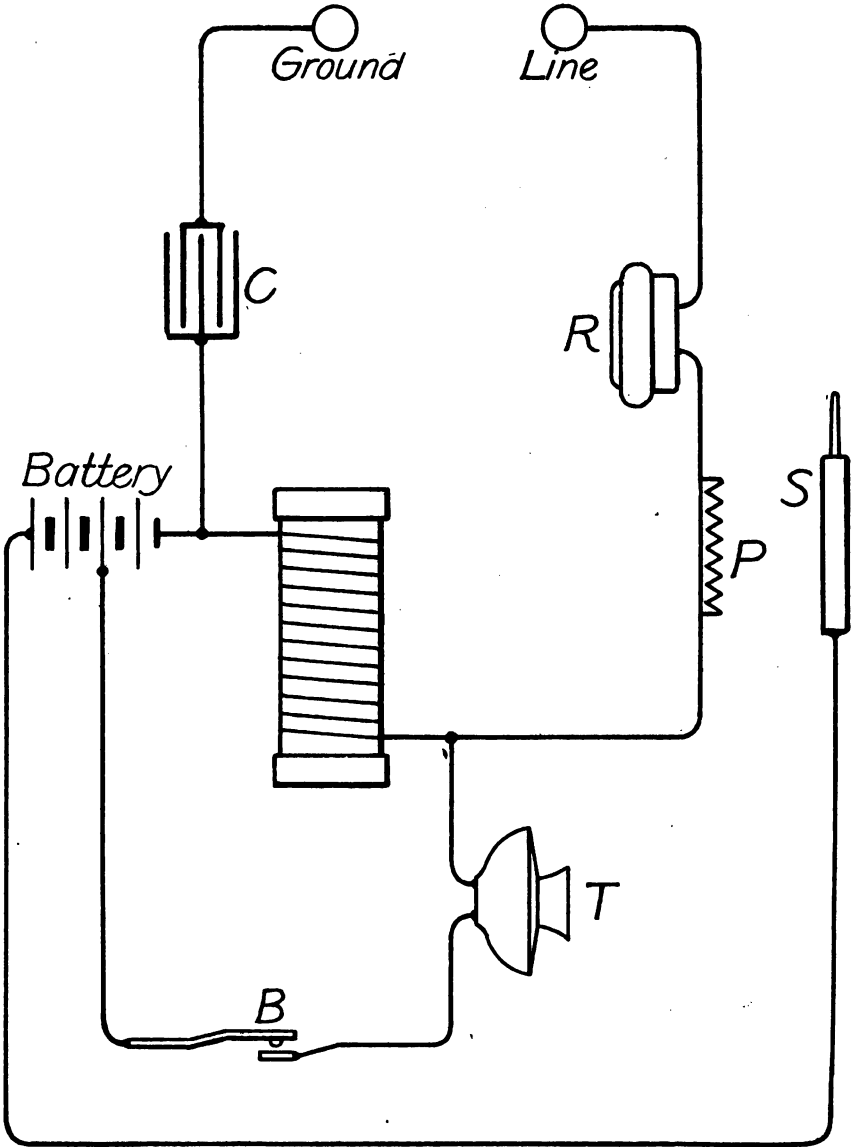

FIG. 91.—Cut-in telephone circuit.

contained in these reports in connection with furnishing supplies on requisitions to supply deficiencies in description or type references.

Standard blank forms, which cover the most essential points to be observed, have been devised for the use of the inspector. It is, how-

ever, a difficult matter to prepare a form which will be of general application and at the same time meet special or unusual conditions which will be found to obtain to a greater or less degree at each military post. This should be borne in mind in making inspections, and entry made of items which, though not specifically called for in the blank forms, would, in the opinion of the inspector, add to the value of the report. The objects to be accomplished by the inspection should be kept in view constantly, and the spirit as well as the letter of the requirements carefully observed.

In the following paragraphs a résumé of War Department orders, which govern this work at the present time, will be given. These orders are modified or superseded from time to time as conditions require, so that it is advisable to obtain information as to current regulations before proceeding to perform inspections.

The following instructions govern the inspection, test, and repair of such of the elements of seacoast fortifications as have been furnished or installed by the Signal Corps:

1. The department commander will cause an annual inspection and test to be made of the entire Signal Corps equipment of each seacoast fortification within his department. Such inspection and test will take place, if practicable, during the three months preceding June 30 of each year, and will be made by the chief signal officer of the department. If that is impracticable, the inspection and test will be made by some other officer of the Signal Corps, or by the district artillery engineer; and if none of these officers is available, then by such other officer of the Coast Artillery Corps as the department commander may designate. Officers designated to make these inspections and tests will give notice thereof, through the artillery district commander, to the post commander, who will furnish such officers with any assistance that may be required. The inspector will be accompanied during his inspection by the district artillery engineer and by the officer immediately responsible for the equipment to be inspected.

2. A report covering the inspection and test, on blank forms provided by the Signal Corps, will be prepared in triplicate and forwarded through the post commander to the department commander. One copy will be withdrawn for file in the office of the chief signal officer of the department and the remaining two copies will be forwarded to The Adjutant-General of the Army for file in the offices of the Chief Signal Officer of the Army and the Chief of Coast Artillery, respectively.

3. Should the post commander learn, at any time other than at the regular inspections, that a serious defect has developed in the Signal Corps equipment at his post, it is his duty to inform the department commander, through the artillery district commander, giving a detailed report in order that, if practicable, the necessary corrections may be made before the next regular inspection. (Extract G. O. 83, W. D., 1909.)

It will be seen from the above that fire-control inspections are to be made annually only. The reports are made in triplicate and forwarded through the commanding officer of the post not later than June 30 of each year. The date on which the inspection is to be made is not fixed, but should be in the last quarter of the fiscal year.

Post telephone systems of the Signal Corps at interior posts are inspected semiannually, as directed in the following extract from G. O. 97, W. D., 1906:

Post telephonic systems are to be maintained and operated by the members of the garrison as a rule, such systems to be inspected by a signal corps or other available expert at least twice each year. Chief signal officers of departments will apply for the necessary orders to have such inspections made.

The dates on which these inspections should be made are not fixed, but may be made at any time within the year. The reports are forwarded through military channels from the post inspected.

ELIMINATION OF TROUBLE IN TELEPHONES.

LOCATING FAULTS.

Experience is the best guide in discovering faults or locating troubles in telephone instruments, and consequently general suggestions only are given. A thorough understanding of the wiring of the telephones and switchboards issued is presupposed, and is of the first importance. There is nothing more necessary and useful in the maintenance and operation of electrical instruments than a thorough acquaintance with the principles and actual circuit wiring of the apparatus. The inspector should be supplied with a key for the magneto box, a small screw-driver, a pair of pliers, an extra receiver, a couple of cells of dry battery, a 4-ohm buzzer, and a magneto, preferably mounted in the form of a lineman's test set.

TELEPHONE.

The usual faults in an instrument are developed under the following conditions: First, the station can not call; second, the station can call, but speech can not be heard in either direction; third, the station can hear, but can not be heard; fourth, the station can be heard but can not hear.

In the first case the fault is in the call box or on the line; in the second case the circuit is either short-circuited or open-circuited; in the third case the fault is in the primary circuit of the transmitter, and may be due to the battery, bad contact in the hook switch, a break or short circuit in the primary or a short circuit in the secondary coil, or else to a broken transmitter. When the station can not ring, first disconnect the instrument from the line and short-circuit the line posts by a piece of wire. If the instrument is of the series type the bell should ring with its own generator, and if of the bridging type the bell should not ring, the handle turning with difficulty. If this occurs the fault is not in the magneto itself, but must be on the line. If in the magneto, look first to see whether the joint connecting the

two magnet coils of the bells is not loose, or whether the soldered joint at the hook switch is tight. These two joints are always soldered with rosin solder. If the joint is improperly made the wires frequently become loose. Test all parts of the circuit for continuity, and see that the automatic shunt is in proper condition. Inspect the pivots and armature of the bell, and see that the armature is at a proper distance from the cores. It is better to adjust the bell by getting the armature at the proper distance from the cores rather than to change the relative position of the bells on their base. The coiled spring in the shaft of the Western Electric type of magneto is sometimes found broken, and the short circuit is not removed from the armature when the handle is turned.

If speech can not be heard in either direction, first test the receiver cords for continuity, and then see if the secondary coil is open. If the distant station can hear you, but you can not hear it, the receiver cord is probably open or there is a short circuit in the receiver windings or at the terminals, or a receiver winding is open. The secondary winding of the induction coil must be in good condition, as it transmits speech to the distant station. Or the receiver may be out of adjustment, that is the diaphragm is not held at the proper distance from the pole pieces. This may be easily tested by unscrewing the ear piece and then holding the receiver in one hand and tapping it against the other lightly. The diaphragm should slide partially off. If it does not start it is either buckled or else too near the magnets. If it falls off it is too far away from the magnets. The receivers are always adjusted before issuing to the service, and it seldom occurs that trouble is due to this cause, and their adjustment should not be altered until the inspector is satisfied that the trouble is entirely due to this source. In screwing up the ear piece on the body of the receiver care should be taken that it is not screwed home too violently, as it will sometimes force the diaphragm down against the magnets, or jam it so that it will lose its natural elasticity. In case speech is heard from the distant station, but it reports that it can not hear the home station, the trouble is in the primary side of the talking circuit. The battery should be examined first, and, as a general rule, whenever trouble develops in the talking circuit, examine the battery before making any other test. If the battery is in good working condition, examine the back contacts of the hook arm, and see that they close when the switch is up; next test the continuity of the primary coil; then examine the transmitter.

A vast amount of annoyance will be saved by frequent and careful examination of all screw connections, as there is a constant tendency for them to work loose, even if fastened by lock nuts. As a very large proportion of trouble is caused by loose connections it is always safe first to examine all connections before looking elsewhere for

the trouble. A poor ground for instruments on ground-return systems is likewise the frequent cause of a weak ringing of the bells or faint talking. The ground plate must be in contact with damp earth; it is not sufficient to put the ground plate a few feet under the surface of the earth where in summer the ground dries out and in winter the earth freezes around and below it. Where both gas and water pipes can be reached the ground wire must be secured to the water pipe. If none is available a gas pipe can be used, and the wire connected with the service pipe, outside the meter; otherwise when the meter is removed for repairs or other causes the line will be opened. The telephone must not be grounded on the same conductor that serves for a telegraph ground.

SUMMARY OF FAULTS.

(a) Station can not call:

Broken wire in box; the ground wire open; the coiled spring on driving shaft broken, or open wire in armature of the magneto. If the handle of the magneto turns with difficulty and the bell does not ring, on a bridging line, a short circuit exists in the line connections of the instrument. Disconnecting one of the line wires will determine whether this fault is on the line or in the instrument.

(b) Station rings distant station, but its own bell remains silent:

Bad connections in box, bells out of adjustment, or open ringer coil.

(c) Station rings other bells strongly, but its own weakly:

The ringer magnet is weak, or bells out of adjustment or partially short-circuited.

(d) Station rings other bells feebly, but receives incoming ring strongly:

Magneto weak, bad connections in magneto, or armature partially short-circuited.

(e) Station rings and receives ring, but can not talk:

Receiver cord broken, bad connections in box, lever arm does not close, poor battery, open circuit in transmitter or induction coil, bad connections in transmitter arm or small retaining diaphragm of transmitter broken and carbon lost.

(f) Station rings frequently without apparent cause:

Swinging cross with telegraph or other exterior lines.

(g) Receiver weak:

Coil partially short-circuited, poor connections, diaphragm bent or dirty, or demagnetized pole pieces. (Diaphragm should be 0.01 inch from the ends of the pole pieces.)

(h) Home station can hear, but can not talk:

Transmitter circuit open or else short-circuited, or batteries run down.

(i) Home station receives speech strongly, but its own talk is weak: Transmitter packed, dampening springs clamp diaphragm too tightly, or batteries run down.

(j) Speech at distant station is indistinct, a scratching or grating noise:

Loose connections, or battery too strong.

When the inspector is satisfied that the battery is strong, a quick test, which will disclose whether the trouble is on the line or in the instrument, can be made as follows: Disconnect the instrument from the line and short-circuit its terminals; place the ear piece of the receiver in the mouthpiece of the transmitter, and if a singing note is heard the talking circuits are clear. If the magneto rings in the case of a series instrument, or in the case of a bridged instrument when the short circuit is removed, the ringing circuit is clear and the trouble, if any, must exist in the line.

The accepted method of cleaning key contacts, or mechanically testing for opens, is by putting a strip of glazed paper between contacts when keys are open, closing the keys, and withdrawing it. If the key does not make firm contact, of course the paper will be easily withdrawn. If it does, withdrawing the paper will clean off any dirt that may be on the contact. This trouble can be removed by adjusting the key.

The location of trouble in cordless boards is more difficult, as each part of the various circuits will probably have to be tested out in succession before the trouble is located.

BATTERY.

Cracked cells, allowing the solution to run out; loose, dirty, or corroded terminals; loose connections on zinc and carbon; zinc rod used up or solution too low, are the usual defects in the battery. The jars should be kept filled between the water lines marked on the cells, the tops kept thoroughly clean and free from salts, and the solution up to its proper strength. The necessary directions for setting up the cell and preparing the battery fluid are to be found on the printed label attached to the cell.

COMMON BATTERY.

Troubles in common battery instruments do not materially differ in character, and are located in much the same way as in local battery apparatus. Omission of the magneto materially reduces likeli-

hood of fault at the substation. Condensers occasionally short-circuit, causing the switchboard signal to operate, and this fault can only be detected by testing the condenser for a flow of direct current.

Line troubles are usually detected by their effect on the central battery. Common battery switchboards as furnished for signal corps work have no adjustments and are in general simpler in their operation than the local battery switchboard.

Batteries used in common battery work are described under "Secondary Batteries," in this manual.

CHAPTER VI.

TELEPHONE SWITCHBOARDS AND THEIR AUXILIARY PROTECTIVE AND POWER EQUIPMENT.

The telephone systems installed by the Signal Corps for the military posts and schools of instruction are constructed and installed in accordance with General Orders, Nos. 97, 1906, and 170, 1908, herewith, and comprise the stations authorized therein :

GENERAL ORDERS, }
No. 97. }

WAR DEPARTMENT,
Washington, May 25, 1906.

General Orders, No. 35, War Department, February 19, 1906, and General Orders, No. 58, War Department, March 21, 1906, are rescinded and the following substituted therefor :

1. For administrative purposes the following telephonic communication is authorized at each military post, to be established by the Signal Corps, United States Army.

The telephones for each post will be located as follows :

Office of the commanding officer-----	1
Office of the quartermaster-----	1
Office of the commissary-----	1
At the hospital-----	1
At the guardhouse-----	1
At the post exchange-----	1
Residence of the commanding officer-----	1
Residence of the quartermaster-----	1
Residence of the adjutant-----	1
Residence of the surgeon-----	1
At the pump house-----	1
At the corral-----	1
At each subpost-----	3

In addition to the foregoing allowance, not to exceed one additional telephone for each organization serving at the post may be installed at points selected by the post commander when certified to be necessary for the public service. These telephones are intended to expedite general administrative affairs at large posts where a number of companies are stationed, and are not primarily intended to be placed at the company offices or barracks.

The central post exchange will usually be located at the adjutant's office.

2. When the Quartermaster's Department finds it necessary to contract for telephonic communication from a nearby town to the offices of the commanding officer, the quartermaster, and the commissary, or such of them as may be necessary, through a commercial telephone company, that department is author-

ized to contract for the rental of a commercial wire, together with a sufficient number of telephones and switchboard, if necessary, for the official business of the post.

3. At large posts where complete private telephone service is desired in addition to that provided by the Signal Corps, a revocable license will be prepared by department commanders and forwarded to The Military Secretary of the Army for the approval of the Secretary of War, covering completely the conditions under which the poles may be erected, the wires strung, and the exchange service regulated, or the whole plant removed when required. This service will be permitted in no case without the approval of the Secretary of War, and will be made an entirely separate installation from the government lines.

4. Telephonic installations for rifle ranges, fire-control purposes, War College, and service schools are not included in the above. They are provided for separately, according to the necessities of the occasion.

TELEPHONE SYSTEMS OF COAST ARTILLERY POSTS.

5. The telephone system of an artillery district constitutes a portion of its defenses and will hereafter be installed on the recommendation of the Chief Signal Officer of the Army and the Chief of Artillery. It will be established and maintained from funds appropriated for fire-control installation.

6. In addition to the telephones authorized at each post by paragraphs 1, 2, 3, and 4, above, for administrative purposes, there will be established in artillery districts, under the provisions of Article I, Revised System of Fire Control, approved April 19, 1905, one telephone at each storage magazine, ordnance machine shop, ordnance storehouse, engineer storehouse, signal corps storehouse, torpedo storehouse, wharf, and power plant.

7. At each post the telephones for administrative purposes, those mentioned in the preceding paragraph, and such other fire-control telephones as may be designated on the recommendation of the Chief of Artillery, will be centered in one switchboard, located at post headquarters, or at such other point as may be recommended by the Chief of Artillery.

8. From each post switchboard in an artillery district there will be one trunk line, and from each battle-commander's station two trunk lines to the post switchboard at artillery district headquarters. Detached posts and battle commands, attached to artillery districts for administrative purposes, will not be included in the district telephone system.

9. In artillery districts provided only with the temporary system of fire control, as prescribed in General Orders, No. 13, War Department, January 16, 1906, the telephones mentioned in paragraph 6 of this order will be established upon the recommendation of the Chief of Artillery as funds are available. Except in cases where existing cables can be utilized the trunk lines from post switchboards and from battle-commanders' stations to the switchboard at artillery district headquarters will be established only in connection with the permanent fire-control installation, and the provisions of paragraph 8 of this order will be subject to such modifications at the time of installation as may be required by local conditions.

10. In order to localize responsibility for the proper care of the switchboard and to secure experienced services the commanding office of the post will, whenever possible, have the switchboard operated by men permanently detailed for that purpose.

11. Post telephonic systems are to be maintained and operated by the members of the garrison as a rule, such systems to be inspected by a Signal Corps

or other available expert at least twice each year. Chief signal officers of departments will apply for the necessary orders to have such inspections made. (1114446, M. S. O.)

By order of the Secretary of War:

J. FRANKLIN BELL,
Brigadier-General, Chief of Staff.

Official:

HENRY P. MCCAIN,
Military Secretary.

GENERAL ORDERS, }
No. 170. }

WAR DEPARTMENT,
Washington, October 23, 1908.

Paragraph 1, General Orders, No. 97, War Department, May 25, 1906, is amended to read as follows:

1. For administrative purposes the following telephonic communications are authorized at military posts, and will be established by the Signal Corps as rapidly as funds become available for that purpose. Each year, as soon as practicable after the passage of the army appropriation bill, the War Department will designate the posts at which the extended telephone system herein authorized will be established during the following fiscal year, and pending such establishment existing post-telephone systems will remain intact, and the number of telephones at posts not designated to receive the extended system will remain the same as those authorized prior to September 30, 1908.

The telephones will be located as follows:

Office of the commanding officer.	The post exchange.
Office of the quartermaster.	The pumping station.
Office of the commissary.	The corral.
Office of the artillery engineer.	Each subpost.
Office of the ordnance officer.	The quartermaster dock.
Office of the local assistant to district engineer officer (when located at the post).	Each picket guardhouse.
Each officer's quarters.	Each barrack.
The hospital.	Quarters of the senior master electrician or electrician sergeant.
The guardhouse.	Quarters of the local assistant to the district engineer officer.

The central post exchange will usually be located at the adjutant's office. (1421566, A. G. O.)

By order of the Secretary of War:

J. FRANKLIN BELL,
Brigadier-General, Chief of Staff.

Official:

HENRY P. MCCAIN,
Adjutant-General.

The telephone switchboards installed for these exchanges vary in size from 15 to 200 line. Those constructed under General Orders, No. 97, 1906, are mostly local battery installations at interior posts and coast artillery posts in the Departments of the Gulf and of Texas. For the installations authorized by General Orders, No. 170, 1908, common battery equipment has been provided. Suitable protective and battery apparatus are installed with each switchboard,

and an effort will be made in this chapter to describe the apparatus thus far installed by the Signal Corps in such a manner as to aid in its operation and maintenance.

In addition to the above equipments the Signal Corps also provides portable switchboards for field use which will be described. Other types are no longer issued, but enough description of these will be given as is required for their maintenance.

CENTRAL ENERGY OR COMMON BATTERY SWITCHBOARD EQUIPMENT.

Coast artillery posts are provided with central energy telephone systems, in accordance with General Order 97, War Department, 1906, and General Order 170, War Department, 1908.

Interior posts are equipped with extensive systems of the same type, in accordance with General Order 170, and are usually designated each year as soon as practicable after the passage of the army appropriation bill. Two types of the switchboard are used, known as the visual and lamp supervisory signal switchboards.

The visual supervisory signal switchboard is equipped with a visual signal for each cord, giving negative supervision of the cord circuit; that is, the signal shows as long as the telephone connected is in use. The lamp supervisory signal switchboard is equipped with a lamp supervisory signal for each cord, and gives positive supervision wherein the lamp is lighted only before and after the telephone connected has answered the call. Descriptions of each type of switchboard will be given hereafter.

CENTRAL ENERGY VISUAL SUPERVISORY SWITCHBOARD.

This type of switchboard is shown in figure 92, illustrating a 50-line capacity board. These switchboards are made in 50, 100, and 200 line capacities, with 10 pairs of cords for the first size, 12 pairs of cords for the 100-line size, and 12 pairs of cords for each two positions of the 200-line switchboard. In addition each operator's position is equipped with a hand generator for ringing purposes, night-bell circuit, battery-test key, line-pilot lamp, and operator's set complete. In addition to the central energy visual line signals 5, 10, and 20 magneto lines and drops are provided in the 50, 100, and 200 line switchboards respectively, for the accommodation of long lines and for interpost lines running in aerial wire or submarine cables, and for commercial trunks. In special cases the number of these magneto lines can be increased in all sizes of switchboards to meet local conditions, but this can only be done satisfactorily at the time of manufacture.

Protector equipment, consisting of heat coils and carbon lightning arresters, are provided for all central-energry switchboards. For the 50 and 100 line sizes a terminal cabinet is provided in which this protector equipment is installed. This cabinet conforms in the essential dimensions to that of the switchboard and is erected as a part of the

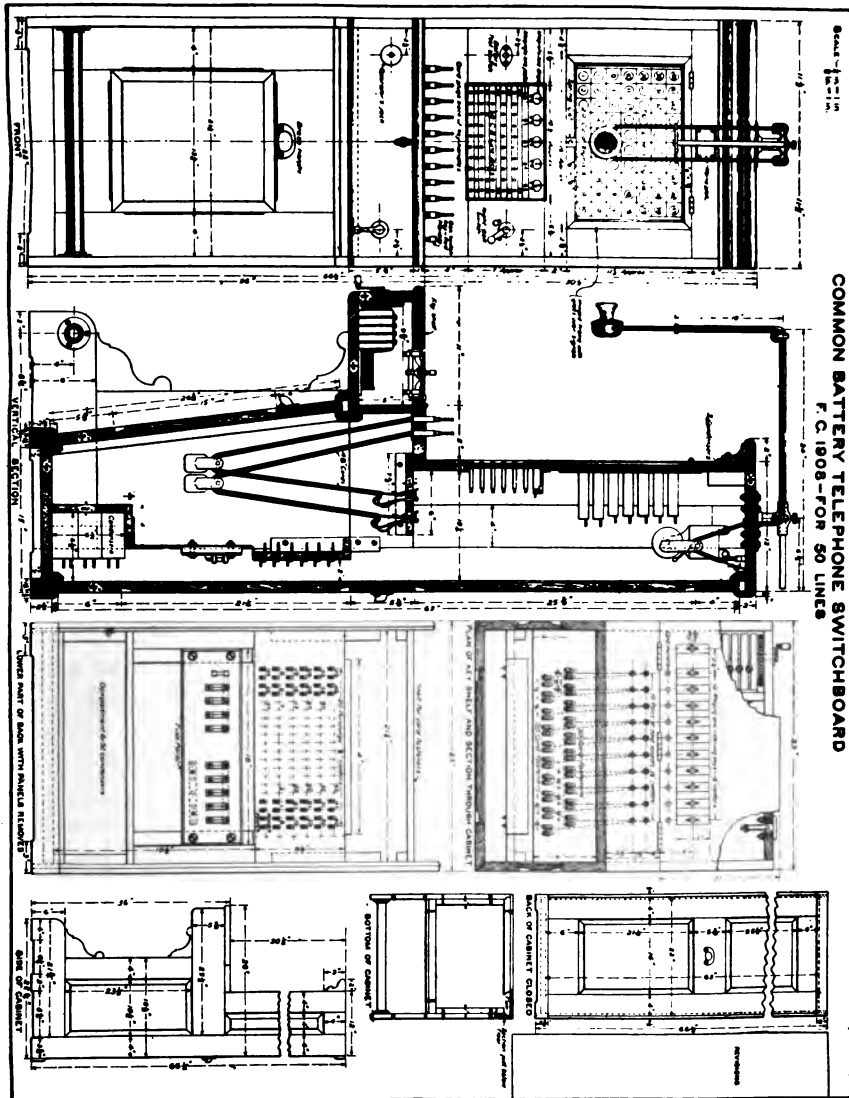

latter, the cabinets being bolted together in such a way as to, in all appearances, comprise one piece of apparatus. The protector equipment furnished usually consists of the Cook type L-8 or Western Electric type 84-B heat coils and carbon arresters. In addition, each cabinet is equipped with sufficient line strips upon which to terminate

the incoming outside cable. This protector equipment will be described in further detail in another paragraph. The circuit of these central energy visual supervisory switchboards is shown in figure 93,

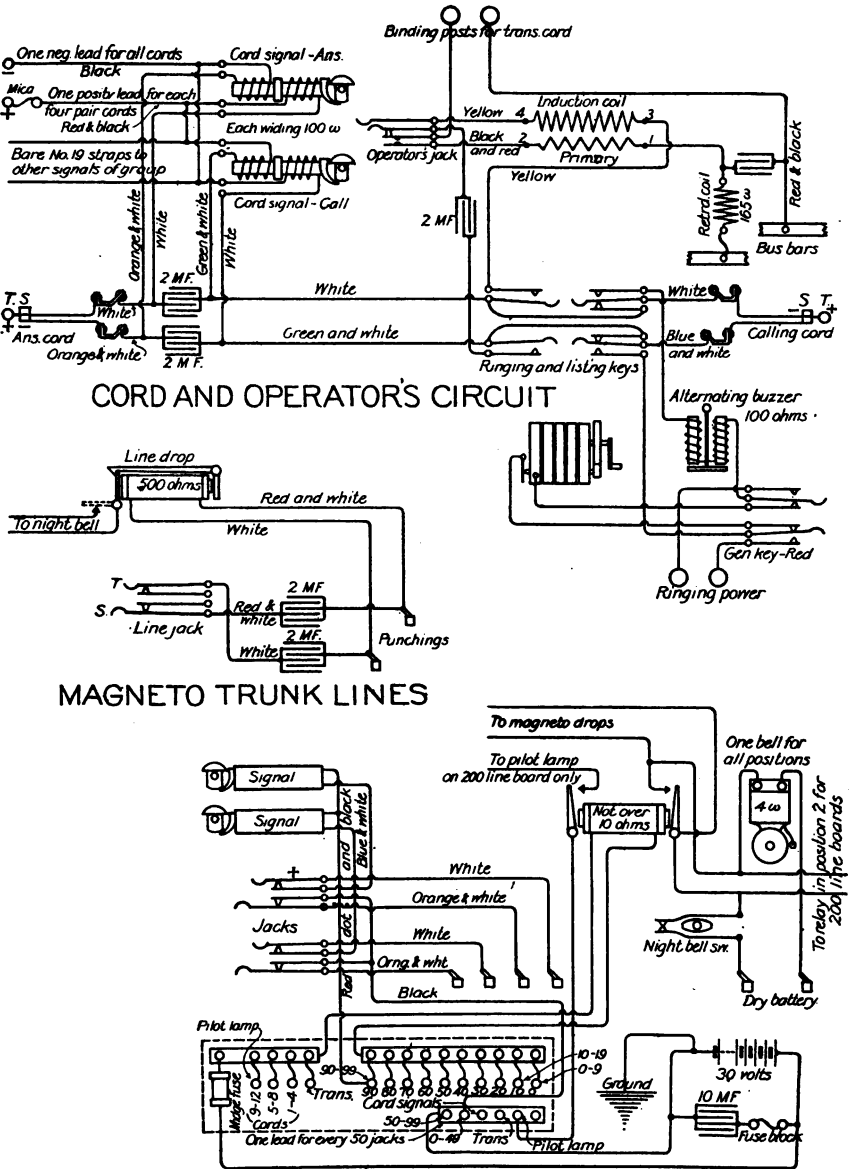

FIG. 93.

which conforms very closely to commercial types, but embodies such features as are required for military purposes. Each cord is provided with a two-coil visual supervisory signal, one coil on each side

or conductor of the cord, and a ringing and listening key. An examination of the cord circuit will show that the supervisory signal also acts as a necessary impedance for the cord circuit. The signals and their impedances are bridged for the high frequency talking current by a condenser in each side of the cord circuit. The ringing and listening key is of the usual type, by which the operator can listen on the back cord by throwing the cam forward toward the cords or ringing on the front cord by throwing the cam toward himself. The connections are made in the usual way by answering with the back cord, the operator listening in by throwing his key cam and obtaining the number of the party desired, then plugging into the desired line jack with his front cord and ringing on this line by pulling the cam toward him.

In addition to the hand generator provision is made for the use of a ringing power, and a key is located on the right side of the keyboard for throwing the ringing key bus-bars from the hand generator to this ringing power. This arrangement is shown on the circuit diagram. A pilot lamp is installed below the line jacks and is so wired that all incoming local calls actuate the relay so that the lamp lights until the call is answered. A night bell is associated with this pilot lamp, which can be thrown in and rings with every incoming call until answered.

This switchboard will operate at either 24 or 30 volts, but when installed at interior posts a 24-volt storage battery is provided for its operation.

At coast-artillery posts where a 30-volt storage battery is installed for the fire-control telephone system this battery is used for the operation of the post telephone system.

A 200-line switchboard of this type usually has an iron protector frame provided, called the main frame, on which are mounted the heat coils and lightning arresters (fig. 109) and line terminals for the outside cables. These are connected to the switchboard on exactly the same principles as when installed in the arrester terminal cabinet, but owing to the size of the iron frame necessary to provide for an increased amount of equipment, it is erected apart from the switchboard, usually close by, in a position where it will not interfere with the operation or enlargement of the switchboard, and so as to meet all the other local requirements. An illustration of this type of installation is shown in figure 94.

CENTRAL ENERGY LAMP SUPERVISORY SWITCHBOARD.

As stated previously, this type of switchboard varies from the one just described principally in the fact that lamp supervisory signals are provided for each cord. Another distinctive feature is that the line jacks are located immediately under the line signals with which they are associated; the latter, however, being more a detail of mechanical construction than of the circuit, the signal and jack being

one removable unit. These switchboards are wired to operate normally at 24 volts, but can be used on a 30-volt system by changing

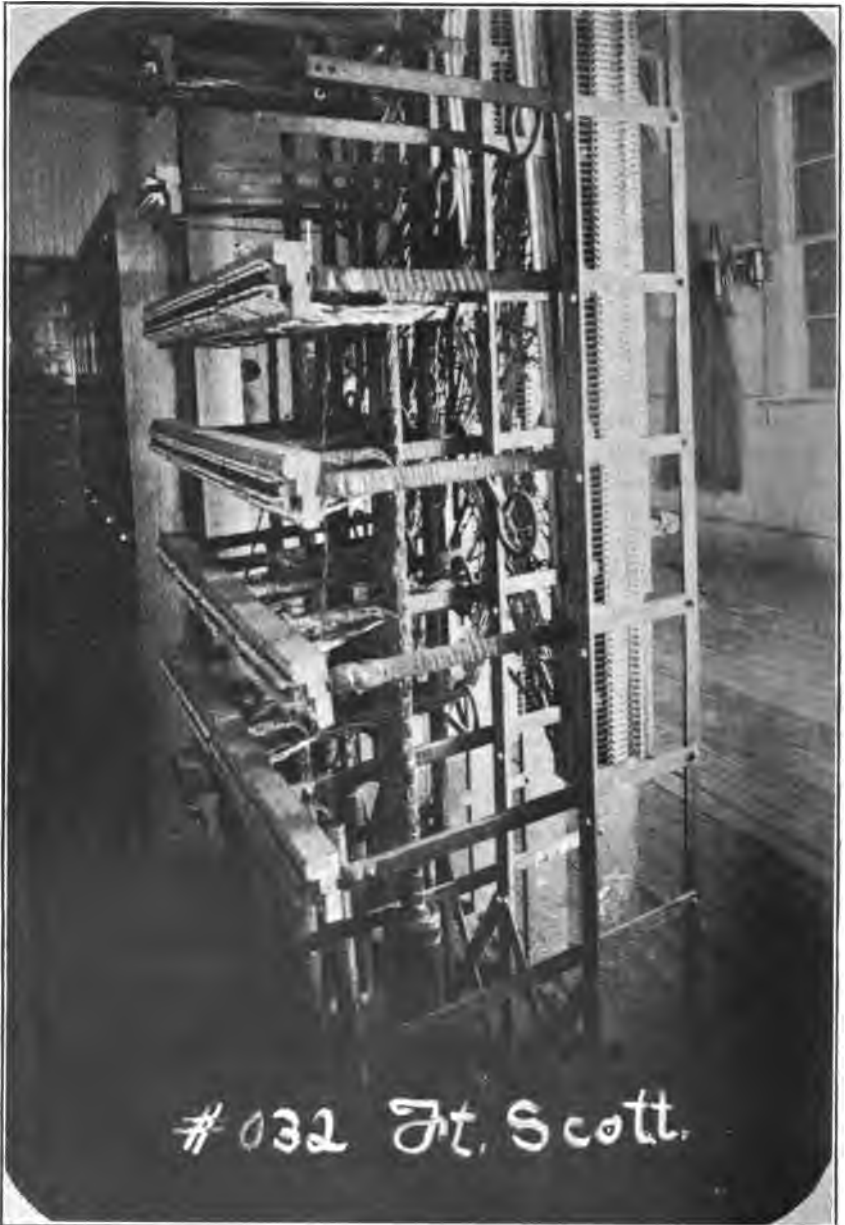
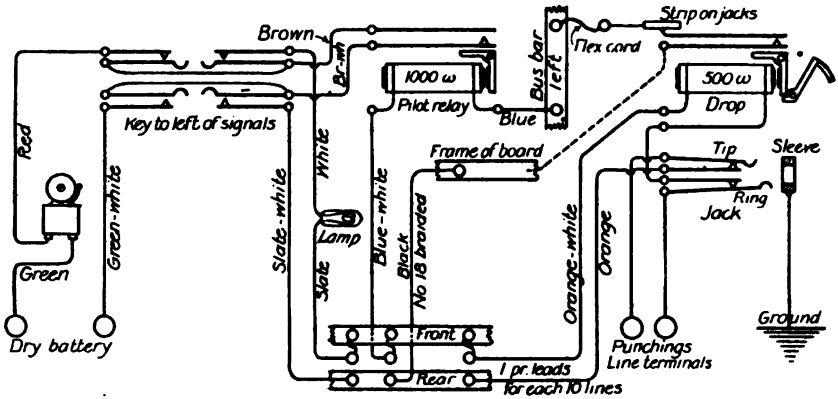
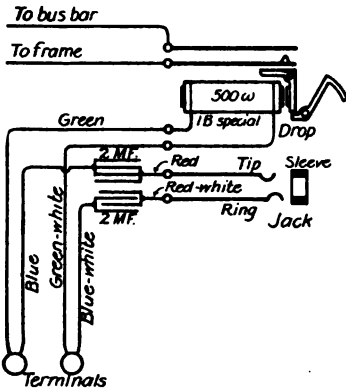

FIG. 94.—Main distributing or cross-connecting frame, Presidio of San Francisco.

the lamp equipment to meet that voltage. The circuit of this switchboard is shown in figure 95.



COM. BAT. LINE CIRCUIT - VIS. SIGS.



MAGNETO LINE

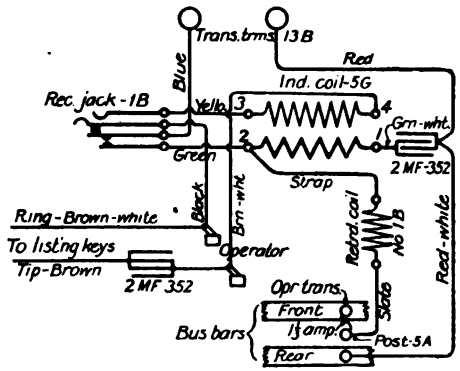

OPERATOR'S TEL. CIRCUIT

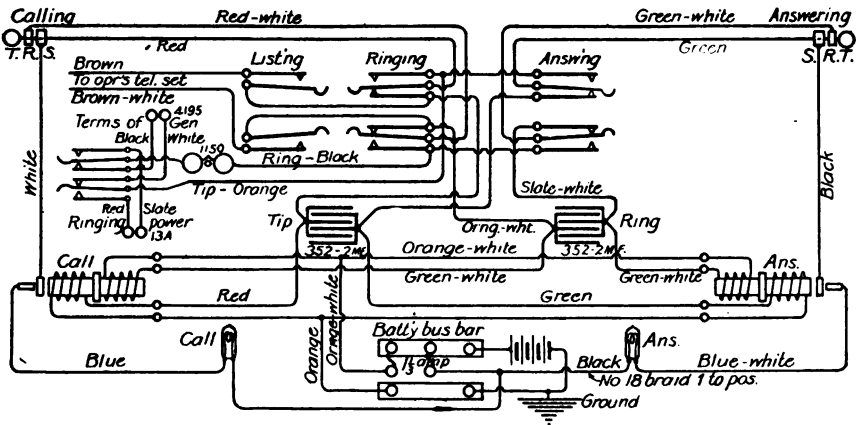

COMMON BATTERY CORD CIRCUIT

FIG. 95.

In the switchboard shown the line signals are of a type which will operate either on the magneto or central energy circuits, so that provision for the two kinds of telephone connections is made in the line jacks and the circuits to the signals. All the line signals are restored mechanically to their original position by the insertion of the plug in their associated jack. The lamp supervisory signals are installed on the keyboard between the cords and the keys. By reference to the circuit, it will be seen that in addition to the provisions made in the cord circuit of the visual supervisory signal switchboard, this switchboard is also provided with means for ringing on the back or answering cord. Practically the same provisions are made in this type of switchboard as to ringing equipment, operator's set, pilot lamp, test circuit, protective apparatus, etc., as are made in the visual supervisory switchboard. Other details of the switchboards will be taken up in this chapter in the directions for installing.

TRUNKS TO COMMERCIAL EXCHANGES.

The magneto line drops provided on the central energy switchboards can be used for incoming trunks from commercial exchanges. It is the usual condition that these lines are of considerable length making a magneto drop desirable. Where this connection is to a magneto exchange no change in the standard circuits is required. Where the connection is made to a central energy commercial exchange, it will be necessary to change the magneto line circuits of the Signal Corps switchboard. The necessary alteration in the line jack and the addition of the bridging impedance coil should be made in the factory when the switchboard is built.

These alterations should be made at the time the board is manufactured, and it should be stated in the requisitions if it is desired that any of these trunks be equipped for central energy commercial trunks.

MAGNETO SWITCHBOARDS.

Magneto switchboards are usually provided for small installations installed under General Orders No. 97, War Department, 1906. These exchanges can consist of a minimum of twelve telephones, and for simplicity of operation and maintenance a magneto system is advisable.

For these small installations, the Signal Corps has applied a 15-drop switchboard, known as the post telephone switchboard. This equipment is shown in figures 96 and 97. These switchboards were made by the Sterling Electric Company under Signal Corps specifications.

This switchboard operates on local battery circuit. It consists of a neat oak cabinet accommodating 15 combined drops and jacks,

5 pairs of cords with clearing-out drops, and 5 grouping jacks. The operator is provided with a single head receiver, and the switchboard

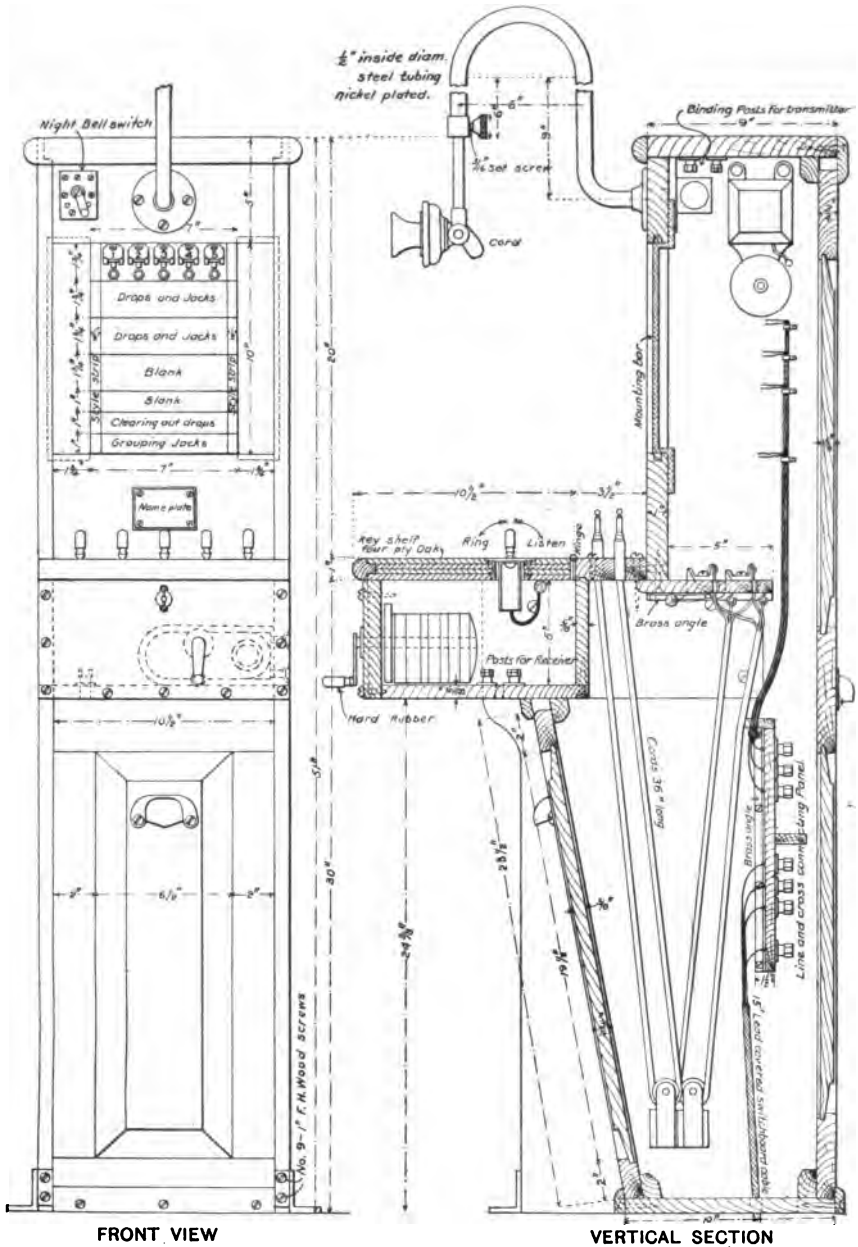
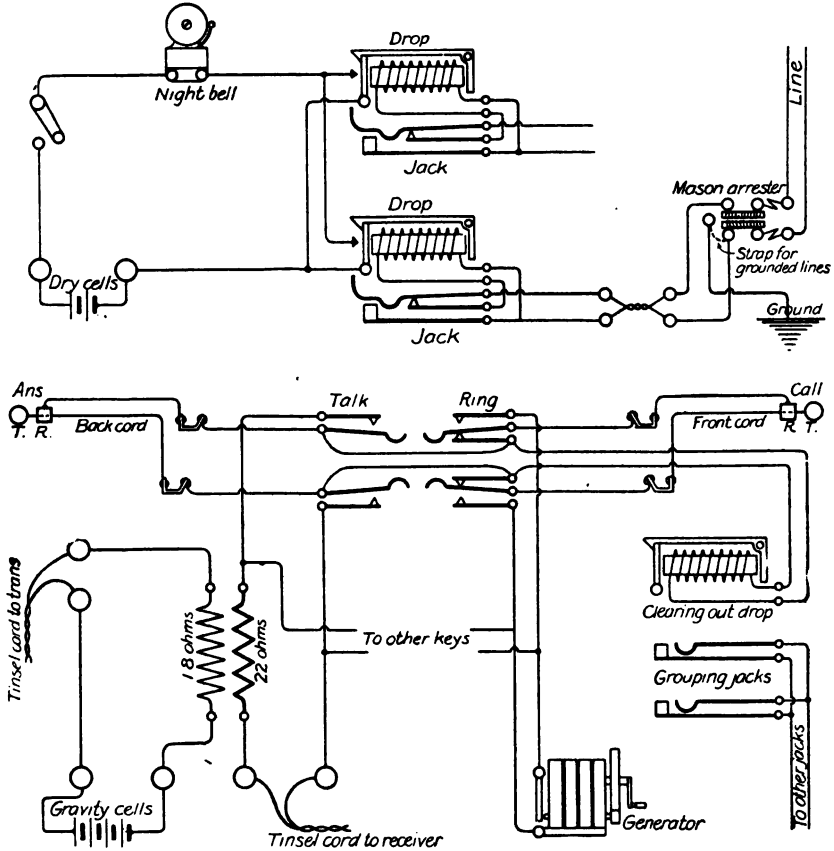

FIG. 96.

has an adjustable operator's transmitter with the usual night-bell circuit.

An arrester cabinet providing for an ultimate installation of 20 Mason or similar lightning arresters with fuses accompanies this switchboard, sufficient cable being provided to reach from the usual location of the switchboard to the arrester cabinet usually installed on the wall at the rear of the switchboard. Lock-nut terminals are plainly marked; the cross connecting is done in the rear of the



Cords should connect in fasteners tip to tip and sleeve to sleeve, ground lines coming in on long or tip springs of jacks

FIG. 97.—Circuit of a fifteen-drop magneto switchboard.

switchboard between the terminals of the line signal circuits of the incoming cable. The operator's circuit is supplied with 4 gravity cells.

The circuit is as follows (fig. 97) :

The calling party signals central by a magneto call, throwing the line drop. The operator inserts an answering plug (opening the drop circuit and at the same time automatically restoring drop shutter) and throws key into talking position.

The connection is established by inserting the calling plug into desired line jack. The conversation completed, the usual ring off throws the clearing out drop, signaling the operator to disconnect. All instruments operating through this board are on local battery.

Grouping jacks are provided to connect several lines together at once by placing answering plug in line jack and calling plug in grouping jack.

The operator's circuit is the simple induction principle used in ordinary telephones.

The drop and jack supplied with this switchboard are similar to the drop and jack supplied with the fire-control type switchboard.

The plug supplied with this switchboard is similar to the plug supplied with the fire-control type switchboard.

The key supplied with this switchboard conforms to the key supplied with the portable telephone switchboard and is interchangeable with it.

These boards are wired for 15-line drops only, and it is not practicable to increase their line capacity without sending them to some Signal Corps supply depot. It is not probable that any more of this type of board will be issued.

This board (Sterling) should have four cells of gravity battery, size 6 by 8, for the operator's telephone, as this telephone has normally a closed circuit, and therefore dry cells or any other type of open-circuit battery should not be used.

50-LINE MAGNETO SWITCHBOARD.

For local-battery telephone systems of more than 15 and not exceeding 50 lines, the Signal Corps has purchased a number of local-battery magneto switchboards. These boards have an ultimate capacity of 50 lines and are so wired. They are supplied to posts with 20, 30, 40, or 50 drops installed, depending upon the number of telephone lines required. In this board the operator's telephone is nominally a closed circuit, and four cells of gravity battery, 6 by 8 size, should be used.

Additional drops and jacks can be supplied for these boards and installed with facility at any time, to increase the capacity up to 50 lines, as the necessary wiring is already complete.

These switchboards were purchased from the North Electric Company and are a stock article of commercial use. Figures 98 and 99 illustrate the appearance and circuit of this equipment.

It has a golden-oak cabinet and is provided with hand generator, 5 pairs of cords with listening and double ringing keys, bridged supervisory magneto drop signals, hand generator and buzzer which can be cut into the ringing as desired for test, two keys for these

various ringing circuits, and operator's transmitter and head receiver complete.

Figure 99 shows the circuit of this switchboard. It will be seen that the line signal *4D* is bridged across the line jack 69 and is cut off from both sides of the line when the plug is inserted.



FIG. 98.—Fifty-drop, North Electric Company magneto switchboard.

The cord circuit is the usual circuit with bridged supervisory signal No. *4E*, which is rung down by the stations connected for call when they ring off at end of the conversation.

The red keys on the left-hand side of the keyboard are those shown in the ringing circuit (No. 94 key). By throwing the key it is possible to cut the No. 102 buzzer in series with the ringing circuit. This is desirable when a line indicates a defective condition. The condition of the line in regard to open or short-circuited wires will be indicated by the action of the buzzer, its loudness being determined by the resistance in the line for a uniform rate of turning of the hand generator.

On certain of the boards the key provided for switching the ringing circuit from power to hand generator, and vice versa, is so wired that it is necessary when using the hand generator to throw the key over from the normal position. Inasmuch as power-ringing current for these boards is seldom available and is not provided, this key should be rewired so that the hand generator is connected directly into the ringing circuit while the key is in its normal position. This may be accomplished by perma-

nently connecting together the outside normal contacts, the key in question being designated as No. 94 in the cord circuit shown in figure 99.

If power current should be available, it should be connected to the springs marked "generator, Nos. 1 and 2" on the terminal board of the switchboard and the key circuit retained in its present form.

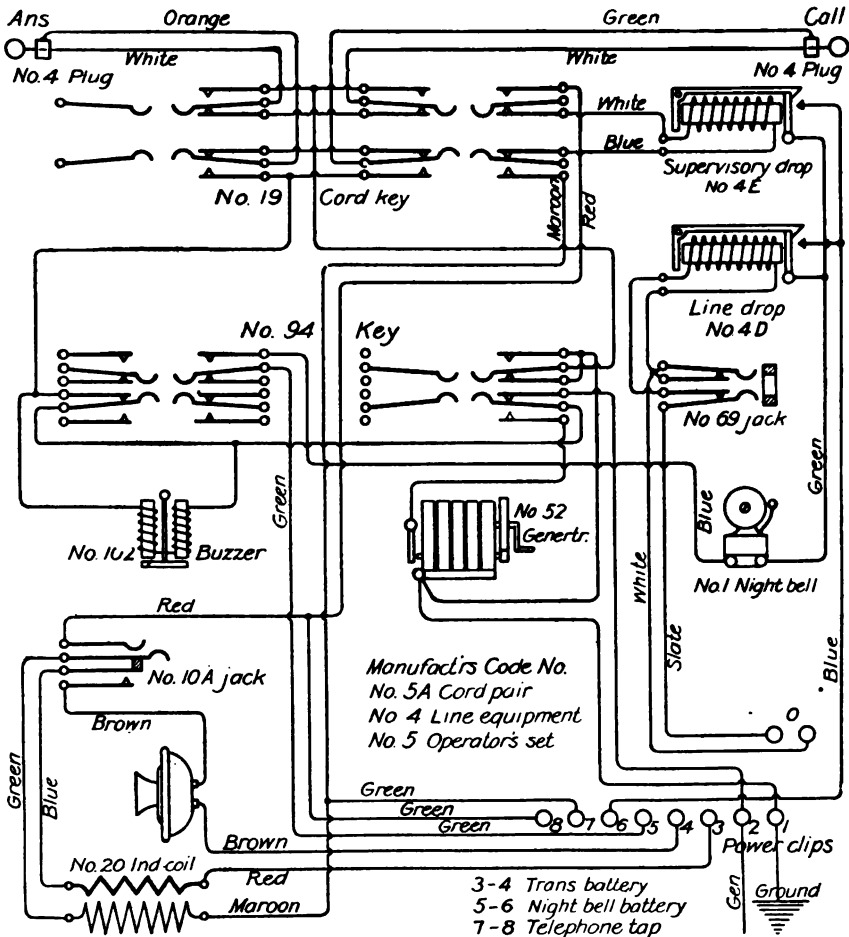

Two No. 94 keys with red handles placed on left side of key board.

FIG. 99.—Circuits of fifty-drop, North Electric, magneto switchboard.

It has also been found in some cases that the generator armatures of these switchboards continue to revolve after a call has been made, thus unscrewing the generator handle from the driving shaft. To avoid this a high resistance will be provided to be bridged across contacts Nos. 2 and 3 of the hand generator shown on the circuits referred to above, in order to furnish a slight load for the generator and cause

the armature to stop as soon as the generator handle is released. A requisition should be made for these resistances wherever their use is considered to be of advantage.

OBSOLETE TYPES OF SWITCHBOARDS.

To cover those types of switchboard now in more or less extended use, but no longer supplied, there are retained descriptions of the wall-cabinet type of 10 and 20 line boards, and of the cordless switchboards, models of 1901 and 1902.

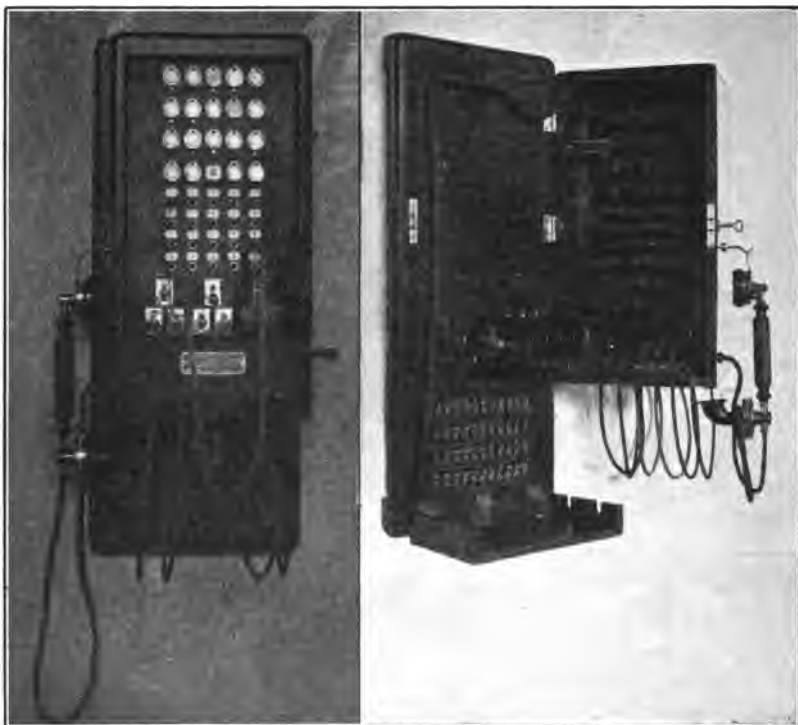

FIG. 100.

WALL-CABINET SWITCHBOARD.

The wall-cabinet switchboard is designed for small exchanges, from 20 to 40 lines, where it is desired to save space.

The working parts are mounted on a hard-rubber panel in the front of the box, which is fastened with strong hinges to the back-board. In the 20-drop board, figures 100 and 101, three pairs of plugs and cords are used, and in the 40-drop board six. The jacks are located immediately below the drops. The upper row of keys serve as listening keys for the pair of cords below them, while the

ringing keys are located just below the listening keys, each one above its own cord. A microtelephone is used for the operator's set, and the drops are supplied with a night-bell circuit. The wiring of this board is shown in figure 101.

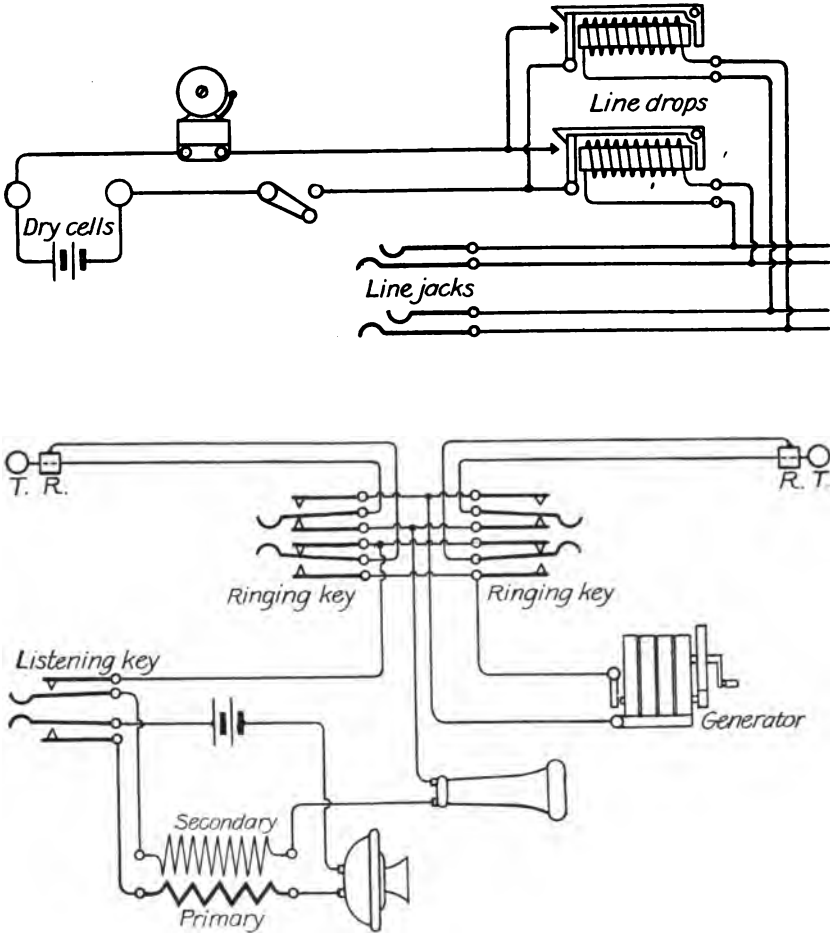

FIG. 101.—Circuit of wall cabinet switchboard.

CORDLESS BOARDS.

1902 model.—A front view and section of this model is shown in figure 102a. This board has neither jacks nor cords. The working parts are contained in a strong wooden case, *A*, the front and back being closed by strongly hinged doors, *B* and *C*. A partition, *E*, is inserted in the front of the box, in the upper part of which is the hard-rubber panel *F*. This hard-rubber panel contains 10 line drops, *G*.

Immediately below this line of drops are inserted two metal strips, *H* and *I*, that contain the keys for ringing and making the necessary connections between the line circuits. Below the panel is inserted a small strip, *K*, holding three listening keys, and below this is the key,

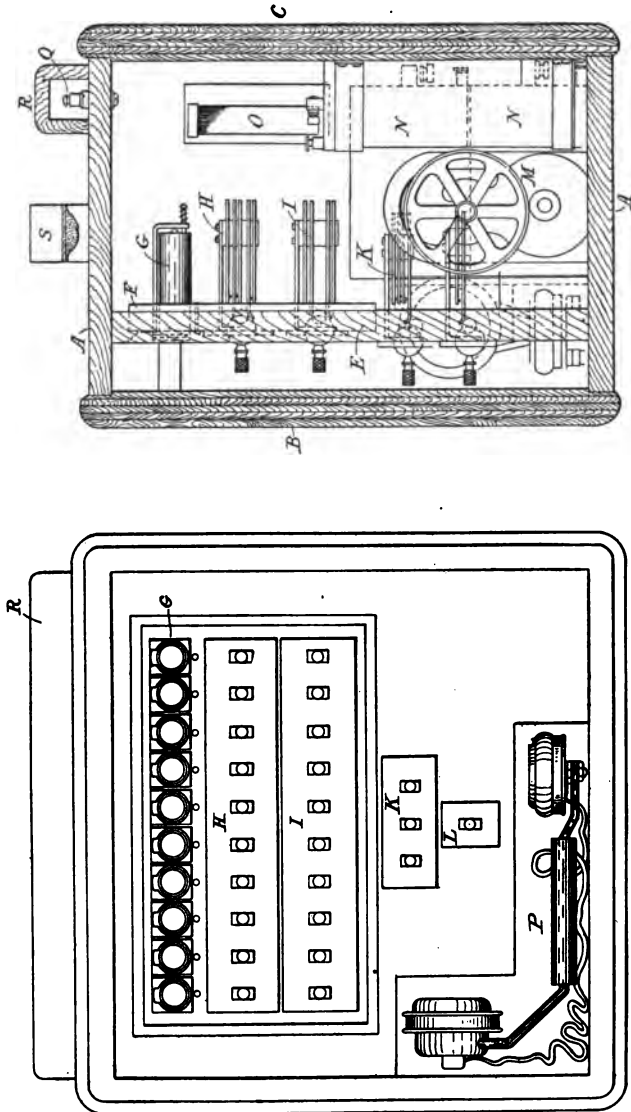

FIG. 102a.

L, that closes the night battery circuit. The magneto *M*, dry battery *N*, and induction coil *O* are securely fastened in the box behind the partition *E*. In a recess in the bottom of the box is the combined receiver and transmitter *P*. On the top is a row of binding posts,

Q , which serve as the line terminals, and are protected by a hinged cover R . The box is carried by the strap S , which passes over the top and is fastened to the sides. The line drops G are bridged across the leads connecting the binding posts Q with the line of keys H . The keys in the rows H and I are normally in a horizontal position, but can be turned either up or down. When the keys in the row H are turned up they serve as ringing keys for the lines immediately above them. When any two keys of the row H are turned down they cross connect their corresponding lines. The keys in the row I when turned up or down cross connect the lines corresponding to them. The keys in the row H are combined ringing and cross-connecting

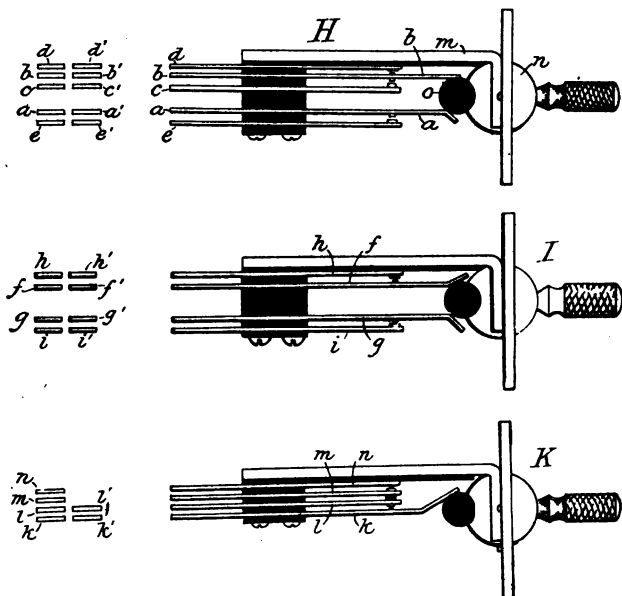

FIG. 102b.

keys and the keys in the row I are cross-connecting keys. The left-hand key of the row K serves as a listening key for the lines cross connected by the down position of the keys in row H , the middle for the up position in the row I and the right-hand one for the down position of I . The key L serves to put the night-bell circuit on the drops. As there are practically three rows of cross-connecting keys, six of the ten circuits can be used simultaneously. To illustrate how the board is operated: When an incoming ring releases the shutter of its drop (if the row H is used) the corresponding key in that row is first turned down and then the left-hand listening key is turned down. When the station which the calling station desires to communicate with is ascertained, the key in the row H corresponding to the desired line is turned up and the generator revolved. This will then call the line desired. As

soon as the call is made the key is then turned down and the two lines are cross connected. As there is no clearing-out drop, when a conversation is finished the ring off will throw both drops, when the connecting keys are then returned to their normal position. Using the row *I*, any two lines are cross connected by turning their corresponding keys in the same direction, remembering that the middle listening key corresponds to the up position and the right-hand one to the down position in *I*. The combined ringing and listening key, *H*, is shown in section and plan in figure 102*b*.

A cross-connecting key of the row *I* is shown in plan and section in figure 102*b*, and is of the same general type as the preceding key, with the exception that it has eight instead of ten springs. These springs are supplied with platinum contacts that are all normally

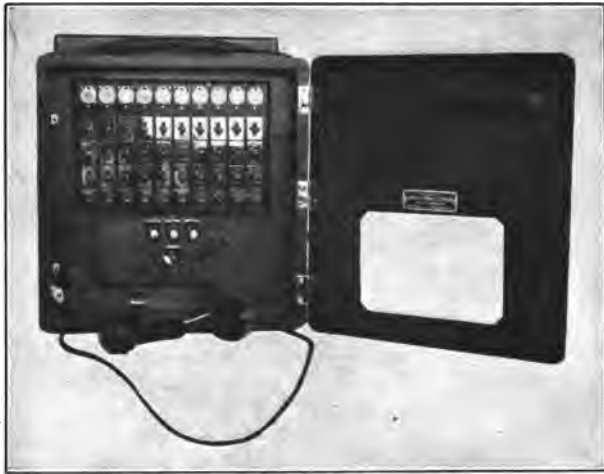

FIG. 103.

open. The springs *c* of each key in figure 102*b* are connected to both *f* and *g* and *c'* with *f'* and *g'*.

The construction of the listening key *K* is plainly indicated. The first cross-connecting strip is connected with the springs *k* and *k'* of the left-hand listening key, the second cross-connecting row to similar springs of the middle listening key, and the third cross-connecting row to the corresponding springs in the right-hand listening key. The receiver circuit is bridged across the springs *l* and *l'*, and the battery circuit across the springs *m* and *n*. When the lever or the listening key is in the normal position all the contacts are open. The wiring of the board is on same principle that is used in figure 104, explained in following paragraph.

1901 model.—The 1901 model is shown in figure 103, and is of the same general construction as the one above described, the difference

consisting in the rows of ringing and cross-connecting keys. There are four rows of keys, the upper row being the ringing keys and the other three rows cross-connecting keys. The method of operation of the board is similar to that of the 1902 model, the only difference

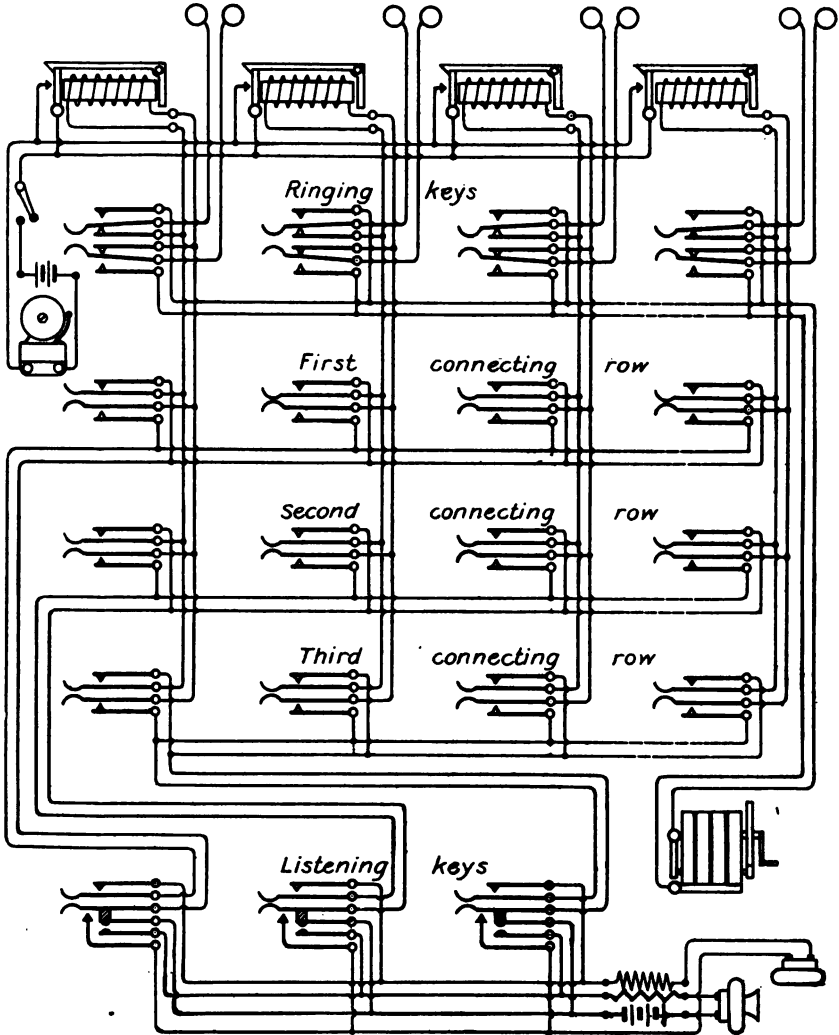

FIG. 104.—Circuits of cordless switchboard, model 1901.

being in the fact that the first row of keys in the 1902 model corresponds to the two upper rows in the 1901 model and the second row in the 1902 model to the third and fourth rows in the 1901 model. The circuits are indicated in figure 104.

INSTALLATION OF TELEPHONE SWITCHBOARDS.

Care should be taken in unpacking switchboard apparatus so that the apparatus will not be injured. Different manufacturers use various methods of packing material so it will not be injured in transit. Different braces will be found in the packing of the apparatus, which must be removed as the material is taken out. If the apparatus is found to be in an injured condition, note should be taken immediately of this fact and witnesses called in for verification, and a report made immediately so that proper action may be taken.

The cord weights are usually tied up and fastened. Relays which have metal covers are usually filled with paper so that the relay will not be injured by shaking. The apparatus should be given a thorough cleaning and cleared with a bellows. Care should be taken that none of the extra parts is thrown away with the excelsior and other packing materials. All fuses should be tested and care taken with the remainder of the apparatus.

Blueprints and instructions usually accompany each switchboard, and these should be followed in the erection of the material.

Telephone switchboards for post systems are usually installed in the adjutant's office, as stated in General Orders, No. 170, War Department, 1908, or in some room of the headquarters building. In selecting the location consideration should be given the following requirements of good telephone service: The room selected should be quiet and free from intruders, so that the operator's attention may not be diverted from his duties. Sleeping quarters for the operators are also desirable if all-night service is contemplated. The necessity of running the lead-covered cables from the switchboard room to the outside circuits should also be remembered, as the protector equipment must always be located in the same room with the switchboard.

The switchboard should be located so that the light falls on the front of the board and so that the operator is not compelled to face a strong light. The back of the boards that are not built for installation on the wall and hinged to swing out for inspection should never be nearer than 2 feet to the wall so that the wiring is always accessible for inspection.

Magneto switchboards are not provided with the switchboard line cables connected, and requisitions should specify the length of cable required to reach the protector cabinet, which is usually installed on the wall near the switchboard and in sight of the operator. The line cable should be neatly formed as directed in a later paragraph and carefully soldered to the line terminals, care being taken to make well tinned joints, as often the resin deposited when soldering is mistaken for solder, and also that corresponding wires of the line cable pairs are connected to similar sides of the switchboard lines.

In connecting the line cables to the protector cabinet the method adopted must be such that there will be no likelihood of the cable becoming wet when the floor is scrubbed or in any other way. For this reason, if the cable is run under the floor, provision should be made for this contingency, as the line cables usually provided and adopted for this work have no particular moisture-resisting properties.

The outside line cables should be potheaded above the floor, the wiped joint resting on the floor and taking up any strain that might otherwise be upon the connections in the terminal or protector cabinet. For magneto switchboards which have separate protector cabinets installed on the wall and apart from the switchboard proper, the top of the pothead sleeve should terminate just inside the bottom of the cabinet and pothead should be clamped securely to blocks on wall and protected from injury.

Inside the cabinet the wires should be formed and laced and permanently held in place by small leather straps so that the work is permanent in every way.

All telephone switchboards should be installed in a permanent manner and the scheme of wiring followed which will minimize the trouble and maintenance work.

The telephone switchboard should always be bolted to the floor so that it will be held permanently in its position and also because the boards are usually top-heavy and not intended to stand unsupported.

The necessary cord, magneto, line, and bus-bar condensers are installed at the rear of the central energy switchboards. A diagram is provided with the different boards for the arrangement of this apparatus. Forms should be made for these connections allowing as much slack as possible for emergencies.

In wiring through the floors porcelain tubes of ample size should be made use of, and great care should be taken in all the cabling that no damage may result to the installation from carelessness on the part of the occupants of the building in which the board is installed.

Where cable forms are required, and particularly at the ends of the cable which is to be used to connect the line wires to the arrester strips, cable forms should be made up as follows:

After the cable is laid in its permanent position its free ends shall be laid parallel to terminals to which it is to be attached. The end of the cable should extend a distance X (fig. 105a) beyond the top

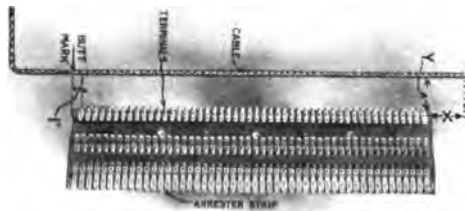

FIG. 105a.

clip of the strip. At the bottom of the strip a butt mark should be made about an inch below the lowermost clip, to which this cable is to be attached.

The outer covering of the cables should then be removed from the butt mark, so as to expose the twisted pairs. This is accomplished by the use of a sharp knife, being careful not to cut the insulation of the wires. The knife should be held in a slanting direction to the

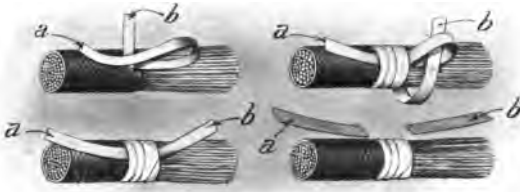

FIG. 105b.—Cable forming.

cross section of the cable in this operation. In cutting the cable around the butt mark, so as to leave a clean end, care should be taken not to cut the insulation or damage the wires. All

binding strips should be removed from the cable with the sheath.

A strip of tape one-half of an inch in width should now be bound tightly around the exposed edges of the cable covering. The operation of binding the cable at this point is known as "butting" and

should proceed as shown in figure 105b. The tape is first looped, and then its long end is wound around the cable four or five times and threaded through the

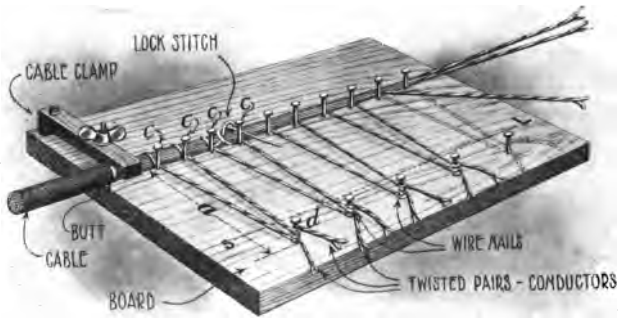
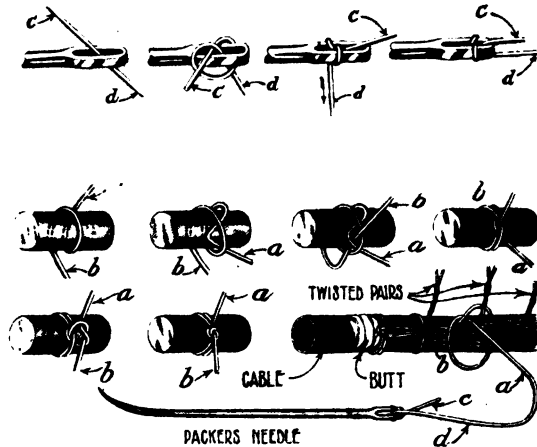

FIG. 105c.

loop which was first formed. The end *A* is then drawn under the turns by pulling the end *B* and closing the loop. Next, the loose ends are cut away and a coating of shellac is applied, completing the butt. The exposed twisted pairs of the standard switchboard cable should now be put in boiling yellow beeswax up to the butt until all the bubbles disappear from the liquid. The purpose of this wax is to expel all moisture and improve the insulation of the wires, and also to prevent the braid loosening up while the form is being completed. All surplus wax should be gently beaten from the cable with a stick when it is removed from the boiling pan.

The cable is now clamped at the butt to the board, as shown in figure 105*c*, and each pair of wires is selected in numerical order, according to the color code, dyed in the insulation of the conductor, and drawn into place and fastened around each successive nail. The length of wire allowed between the stem of the cable and the nails is always in excess of that necessary to reach the clips that must be connected. A spare pair of wires is left projecting at the end of the cable, so that it may be used in case any one of the regular pairs becomes defective. The formed part of the cable is sewed up with a stout waxed linen twine by the aid

FIG. 105*d*.

of a 4-inch packer's needle, which facilitates the passing of the twine under the bunches of wire. The line *S L* indicates the length of wire needed to connect the cable in position.

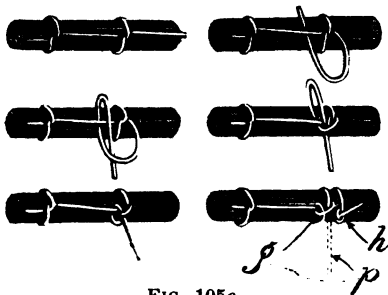
FIG. 105*e*.

This needle, with the method of threading it, is shown in figure 105*d*. Before sewing up, three turns of twine should be taken next to the butt, drawn up taut, and tied with the knot shown, in which *a* is the needle end of the twine and *b* the short end. All line wires are bound together from this point to the end of the twine with what is called a lock stitch, shown in figure 105*d*.

A stitch is taken at each nail, and if the space between is over 1 inch an extra stitch should be taken. In making the stitch the needle is passed under the wires and through a loop, as shown in figure 105*e*, being careful not to include in the loop the stitched part. The loop should hold without fastening after the string is removed from

the needle end of the cord. The last stitch is reenforced by a knot, *g*, after which it is preferable to take another stitch and knot *h* around the spare wires and the other side of the last regular pair.

Before taking the cable from the forming board the ends of the nails should be cut off even with the wires and the insulation removed from the ends of each, using the line *S L* as a guide.

The skinning should be done with a sharp knife, drawing it from the line *S L* toward the end of the wire, at the same time pulling off the covering, which will slip off as soon as the threads are severed. Great care must be taken not to nick the wire, as it would then be liable to break at this point upon being moved or handled.

The tips should now be shellacked lightly and allowed to dry. This prevents unraveling of insulation when soldering.

If the wires are to be soldered to the terminal clips, their bare ends should be threaded, through the holes in the clips, up to the insulation and bent back. If no holes are provided, they should be wound close around the notched portion of the clip. Care must be taken to get the insulation out of the notch in the clip or the hole. Only resin solder should be used in making soldered joints. After soldering, the free end of the wire should be cut off close to the clip and each joint tested.

The cable should now be strapped in place with leather saddles. When the forms are installed they may be finished with a coat of white shellac, which keeps the dust and dirt from sticking to the wires which have been boiled.

A standard signal corps switchboard cable is provided in two sizes, containing, respectively, 20 twisted pairs with 1 spare pair and 1 odd wire, and 40 twisted pairs with 2 spare pairs and 1 odd wire. Twenty-pair cable is ordinarily used.

In connecting this cable the following arrangement of colors should always be adhered to. Under no conditions should any other sequence of colors be followed, as this arrangement is standard and is a very important guide to the operator in maintaining this system.

The code is as follows:

For the 20 pair:		
First pair	Blue	White.
Second pair	Orange	White.
Third pair	Green	White.
Fourth pair	Brown	White.
Fifth pair	Slate	White.
Sixth pair	Blue-white	White.
Seventh pair	Blue-orange	White.
Eighth pair	Blue-green	White.
Ninth pair	Blue-brown	White.
Tenth pair	Blue-slate	White.
Eleventh pair	Orange-white	White.
Twelfth pair	Orange-green	White.
Thirteenth pair	Orange-brown	White.
Fourteenth pair	Orange-slate	White.
Fifteenth pair	Green-white	White.
Sixteenth pair	Green-brown	White.
Seventeenth pair	Green-slate	White.

For the 20-pair:		
Eighteenth pair.....	Brown-white.....	White.
Nineteenth pair.....	Brown-slate.....	White.
Twentieth pair.....	Slate-white.....	White.
For the 40-pair:		
Twenty-first pair.....	Blue.....	Red-white.
Twenty-second pair.....	Orange.....	Red-white.
Twenty-third pair.....	Green.....	Red-white.
Twenty-four pair.....	Brown.....	Red-white.
Twenty-fifth pair.....	Slate.....	Red-white.
Twenty-sixth pair.....	Blue-white.....	Red-white.
Twenty-seventh pair.....	Blue-orange.....	Red-white.
Twenty-eighth pair.....	Blue-green.....	Red-white.
Twenty-ninth pair.....	Blue-brown.....	Red-white.
Thirtieth pair.....	Blue-slate.....	Red-white.
Thirty-first pair.....	Orange-white.....	Red-white.
Thirty-second pair.....	Orange-green.....	Red-white.
Thirty-third pair.....	Orange brown.....	Red-white.
Thirty-fourth pair.....	Orange-slate.....	Red-white.
Thirty-fifth pair.....	Green-white.....	Red-white.
Thirty-sixth pair.....	Green-brown.....	Red-white.
Thirty-seventh pair.....	Green-slate.....	Red-white.
Thirty-eighth pair.....	Brown-white.....	Red-white.
Thirty-ninth pair.....	Brown-slate.....	Red-white.
Fortieth pair.....	Slate-white.....	Red-white.

For the central energy boards of from 50 to 100 line capacity, 20-pair line cables for connecting from the switchboard to the arrester or protective equipment are provided. The line cables are furnished as part of the switchboard, which is usually received with these cables connected to the terminal strips on the back and of sufficient length to reach into the protector cabinet which is erected next to and as part of the switchboard. The code scheme given is followed in all switchboard wiring, but it will be impossible to make up the cable for the protector strip on a temporary form. However, this is easily met as follows:

All cables are butted, as described, at the bottom of the arrester strip, after cables are measured off for their permanent position. The wires are then boiled in beeswax, as instructed, and each pair brought through the forming holes of the protector strip in the same order as their connection to line signals. That is, the No. 1 signal is connected to the No. 1 arrester, then when all wires are in place the cables are laced into one stem and the whole shellacked and soldered as in the first case. By this method the arrester strip itself is used as the form for lacing. No slack is allowed in this form, care being taken to connect all wires correctly the first time. All extra wires are run to the top of the form and dead-ended. For 200-line central energy switchboards which have iron frames for their protector and outside line cable terminal equipment, and which are erected separate from board and some distance from it, according to local conditions, no line cables are provided. These must be made up locally to meet the conditions.

Figures 94 and 106 show an installation of this kind. The wooden box or cable chute running up the left end of the switchboard carries the line cables to the protector frame, where they are distributed from the top to the protectors on the vertical strips.

The switchboard will be supplied with one or more spare jacks and drops. One of these jacks should be used for the purpose of testing cords. The magneto line signals should be disconnected from the spare jack and a cell of dry battery should be soldered across the line terminals. When a plug is installed in this jack and the cord is shaken, a cut-out will be detected by a rasping noise in the receiver of the operator.

The generator call drops should be adjusted so as to fall readily on about five cells of dry battery.

When the switchboard is completely installed, and before it is cut over to the working lines, care should be taken to test for cross talk and incorrect connections in the circuit from the heat-coil terminals to the line jacks. Under no conditions should the switchboard be put into commission when any cross talk is noticeable. It will be found sometimes that the key contact fails to break on the operator's listening circuit and thus crosses the lines with the other keys. Dampness in the switchboard may also cause trouble of this kind.

All power connections should be poled alike.

INSTALLATION OF PROTECTIVE APPARATUS.

It is the practice to provide protection at the switchboard room for all lines entering the telephone switchboard even though none of the line circuits are exposed aerial lines. For magneto lines Mason arresters, or similar individual pair arresters consisting of a mica fuse and a multi-discharge lightning arrester, are installed. For central-energy lines heat coils and lightning arresters are provided.

MAGNETO SWITCHBOARD PROTECTORS.

The protection for magneto switchboards is usually installed separate from them; in most cases on the wall near by and within sight of the operator. A cabinet of the same wood and finish as the switchboard is provided for the installation of the necessary number of Mason arresters.

The connections between the switchboard and the protector cabinet should be made by means of 20-pair cable, rubber insulated, with code color braid. Over the entire cable is a waterproof covering for protection and insulation. The color scheme is similar to that given for switchboard installation and should be carefully followed, as stated therein.

The forms for both the switchboard and protector ends should be carefully laced, each wire being brought out at its particular line spring or arrester. The switchboard end should be carefully soldered after the wire is passed through the hole and wrapped around the spring. The forms should be shellacked when completed, but never

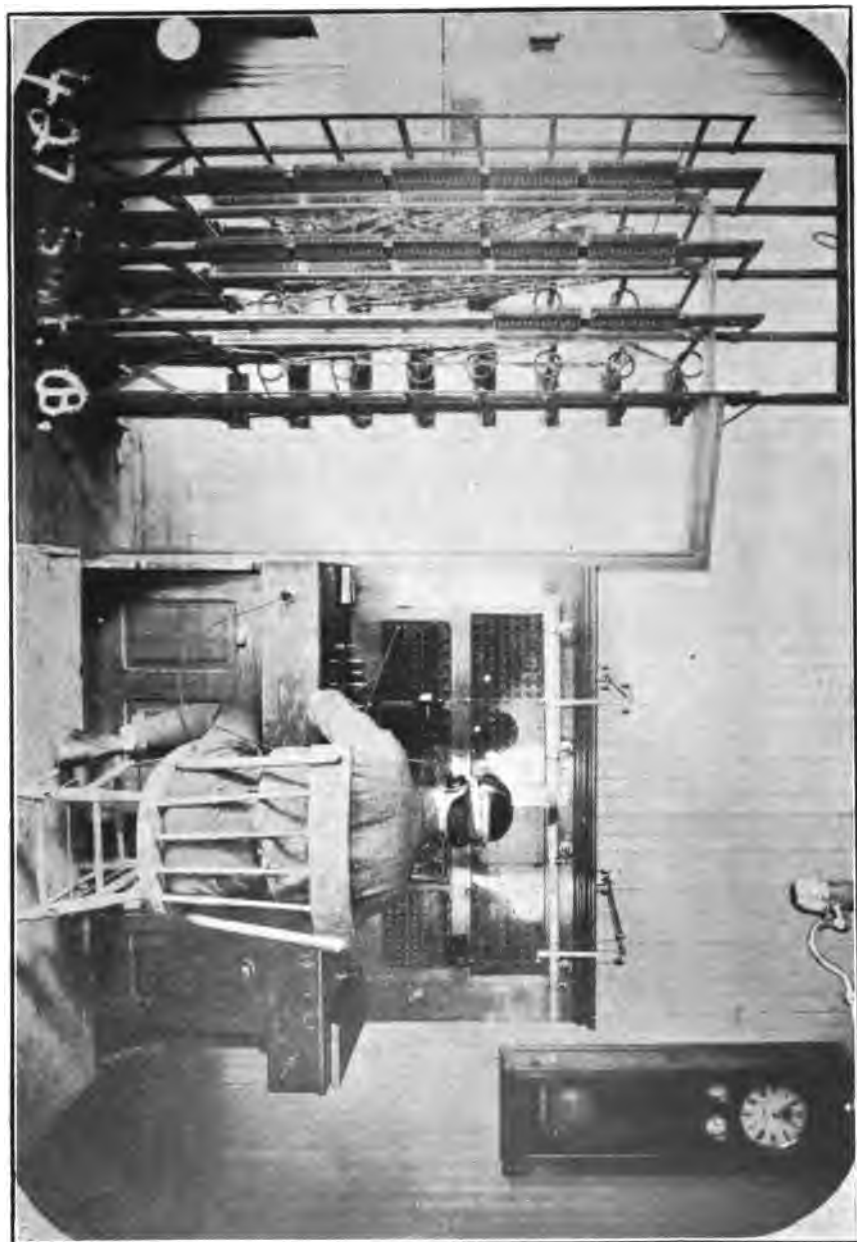

FIG. 106.—Two hundred line central energy switchboard and main distributing frame.

boiled in beeswax, which injures rubber insulation. It is best to run the line cable under the floor, running down through the bottom of switchboard and coming up directly under the point of arrester cabinet it is desired to enter, protecting it with loricated conduit between the floor and cabinet, and under the floor provision should be made to protect the cable from moisture.

The outside lines should always be brought into the office and cabinet in cable, even though the length of cable is short. If over 12 pair in size this cable will necessarily be paper insulated with lead sheath, and should be potheaded at both ends to terminate the conductors in rubber insulation. The methods of potheading will be described in another chapter. The pothead sleeve should be carried into the protector cabinet and protected by loricated conduit between the floor and cabinet. Inside the cabinet the pothead wires should be carefully laced after the wires are brought out to their respective arresters.

These forms should be thoroughly shellacked after they are formed, laced, and tied in place.

CENTRAL ENERGY SWITCHBOARD PROTECTORS.

The protective apparatus for these switchboards differs from that provided for magneto switchboards. One pair of lightning arresters and heat coils, as shown in figure 109, are provided for each line, both central energy and magneto. In addition a strip for terminating the outside cable pairs is provided which usually exceeds the arrester pairs by 30 per cent, as necessarily more outside cable pairs are installed than will be actually used by lines.

These arrester and line strips for the 50 and 100 line switchboards are installed in a cabinet such as is shown in figure 107, and in the manner illustrated. However, the relative position of the strips can be changed, as the arrester strip should always be nearest to the switchboard, so as to remove the necessity of running the line cables from the switchboard past the outside lead-covered cables.

The cabinet shown is erected against the telephone switchboard and bolted thereto so that in effect they comprise one cabinet or fixture. The local conditions may affect their relative positions, but the door of the protector cabinet can be hinged on either side and the strips changed inside so any condition can be met.

The two cabinets are exactly alike in finish and essential dimensions and built to be erected together.

The line cables from the 50 and 100 line switchboards are usually connected to that end when received, and sufficient length allowed for connecting to the arrester strip in the protector cabinet, to which they are run by cutting a hole in the bottom of the partitions between the two cabinets and lacing the cables together.

The line cables are "butted" and formed as described in this chapter, the color code being followed carefully, and corresponding numbers on the arrester strip assigned to line signals of same number. The magneto drops are connected immediately below the central energy lines, allowing for full capacity of the switchboard. The full protector equipment is furnished in the protector cabinet for each central energy switchboard.



FIG. 107.—Switchboard installation (terminal cabinet on right).

The 20-pair line cables are boiled in beeswax preferably, or paraffin if necessary, and laced up into one form and strapped securely to the back of strip on which arresters are mounted, as shown in figure 107. The wires should be carefully soldered to the springs, first wrapping the wire around notch, which is already tinned.

The line cable provided for central energy switchboards is insulated with two silk and one cotton covering and has no particular moisture resisting qualities. It should never be installed under a

floor where it may become wet from scrubbing or by any other means. It will retain its insulation when installed in a dry room, but it is not intended for exposure. Neither should this type of cable be used for potheading the outside line cables.

The cables to the outside circuits should be brought to the cabinet in the most workmanlike way that will meet the local conditions. It is usually possible to bring them into the switchboard room directly under the cabinet by running in walls and under floors. Whenever the cables are exposed in the headquarters building they should be protected by loricated conduits. In terminal cabinets they should be potheaded directly under the line terminal strip and arranged to be strapped to the horizontal angle-iron piece holding the arrester and line terminal strips. It may be necessary to move this iron toward the front of the cabinet, or provide a new iron strap, as the space usually left between the iron strip furnished and the removable rear door is insufficient to get in the cable. The potheads and wiped splices should rest directly on the floor of the cabinet and thus take up any strain that may be on the cable.

Rubber-covered No. 19 duplex wire is always used for these potheads, and where several cables are brought in they are laced into one form on the back of the line-terminal strip to which they are connected.

Rubber-insulated wires should never be boiled in beeswax or paraffin, but the forms should be shellacked after they are laced and soldered in.

The potheads should be carefully aligned when installed and an effort made to use sleeves of the same length and diameter so that the tops will be level when they are completed.

It will be found desirable to install the arrester cabinet on the right-hand side of switchboard, facing it, as this will bring the cross-connecting springs for interconnecting the switchboard cables terminating on the lightning arresters, and therefore the outside line cables, next to each other, simplifying the cross-connection work.

This will require that the door be hinged on the right side, but this can be done quickly if necessary. An illustration of this type is shown in figure 107.

Outside line cables are brought to the main iron frames provided for 200-line boards in the same manner used for smaller switchboards.

At the main frame the cables are brought through the floor in a position depending on the 20-pair line blocks to which they are assigned.

The potheads rest on the floor and are brought up alongside the vertical line of iron braces holding the line blocks to which the cables are connected. The cables to be connected to the top line terminals

will naturally be brought in farthest from the bottom block. The potheads should preferably be of same size and height of sleeve and the wires carefully laced and shellacked when formed and in place. The form should be carried straight up and branched to the blocks at the iron braces, to which they should be neatly fastened by tape.

The line blocks number from the top down and spare blocks should ordinarily be left at the bottom. A cable should be distributed on one vertical row of line terminal blocks.

THE CENTRAL ENERGY STORAGE BATTERY.

As indicated by its name, the central energy telephone installations obtain all the battery for their operation from one common or central source in the form of a storage battery. It is therefore one of the most essential features of the system, and particular care must be taken in its erection to insure reliability of service, as a failure of this battery renders the entire system inoperative.

As will be seen from an examination of the circuits for central energy switchboards all circuits center in the batteries, and the most important feature of the system should be the certainty that the bus-bar leads between the battery and switchboard and the battery have practically no resistance, as this part of the circuit is common to all talking circuits, and will be the source of cross talk if the resistance is appreciable.

At coast artillery posts the central energy will be obtained from the telephone storage batteries installed to operate the fire-control telephones, and these will be installed in accordance with the instructions in Manual No. 8. These batteries vary in size according to the extent of the installation and operate at 30 volts, requiring 15 cells, usually of 80 to 240 ampere hour capacity. The battery leads from the fire-control switchboard rooms are usually of considerable length so that cross talk would result if arrangements are not made to meet the conditions.

Several pairs of wire in the trunk cable are used for the feed lines of the post telephone system. These are bridged by a considerable capacity in the form of a foil condenser at the bus-bars of the switchboard. These condensers afford a short circuit for the talking current and maintain an approximately constant E M F, at the switchboard bus-bars. Individual condensers in each cord circuit bridged across the supervisory signals also reduce the tendency to cross talk.

At posts where this fire-control battery will never be available a separate storage battery equipment is installed. This battery should be installed as near the telephone switchboard as practicable, considering the other factors that must be met.

The battery required for a post system seldom exceeds 24-ampere hour capacity; this permits the installation of the two plate or "coupled" type of cell minimizing the amount of space necessary.

To insure reliability, a duplicate battery is usually installed.

Batteries of these small sizes are more easily charged by whatever direct lighting current is available on the post.

Typical charging panels for this service are shown in the storage battery chapter.

The size of storage battery furnished is determined not only by the current requirements, but also by the necessity of providing a battery of low internal resistance, and this has been considered in the instructions above. For central energy telephone installations at interior posts 2-plate, 3-ampere normal discharge rate storage batteries will be provided hereafter. Duplicate sets of batteries will be installed if conditions warrant.

As the switchboard should be installed in the headquarters building, the battery should also be erected in this building, and as probably no room will be available for battery purposes only, these batteries should be installed in a cabinet of the type shown in figure 108. This should be installed in a dry location and provided with a suitable vent to the open air to carry away the acid fumes.

The cabinet should be painted inside with some black acid-proof paint.

The charging panel should be installed near the telephone switchboard so that it is accessible to the operator. The connections between the panel and battery cabinet should be carefully installed and loricated conduit used where the lead cable leads are exposed to injury.

An open storage battery should never be installed in the same room with the telephone or charging panel unless inclosed in the cabinet described herein. In fact an open battery should only be installed in a location meeting all other requirements, and from which unauthorized persons can be excluded.

The storage battery equipment that will be furnished for telephone installation with the 50-line switchboard will consist of two sets of 3-ampere normal charge rate batteries. Where direct current of not less than 40 volts and not more than 220 is available, these cells will be charged through lamps by means of the charging panel, figure 18, shown in Chapter II.

Where only alternating current is available a special motor generator and panel will be provided. The motor side will be built to meet the characteristics of the power circuit, and to that end a requisition for this machine should always state the voltage, number of phases, and frequency of the alternating power current available.

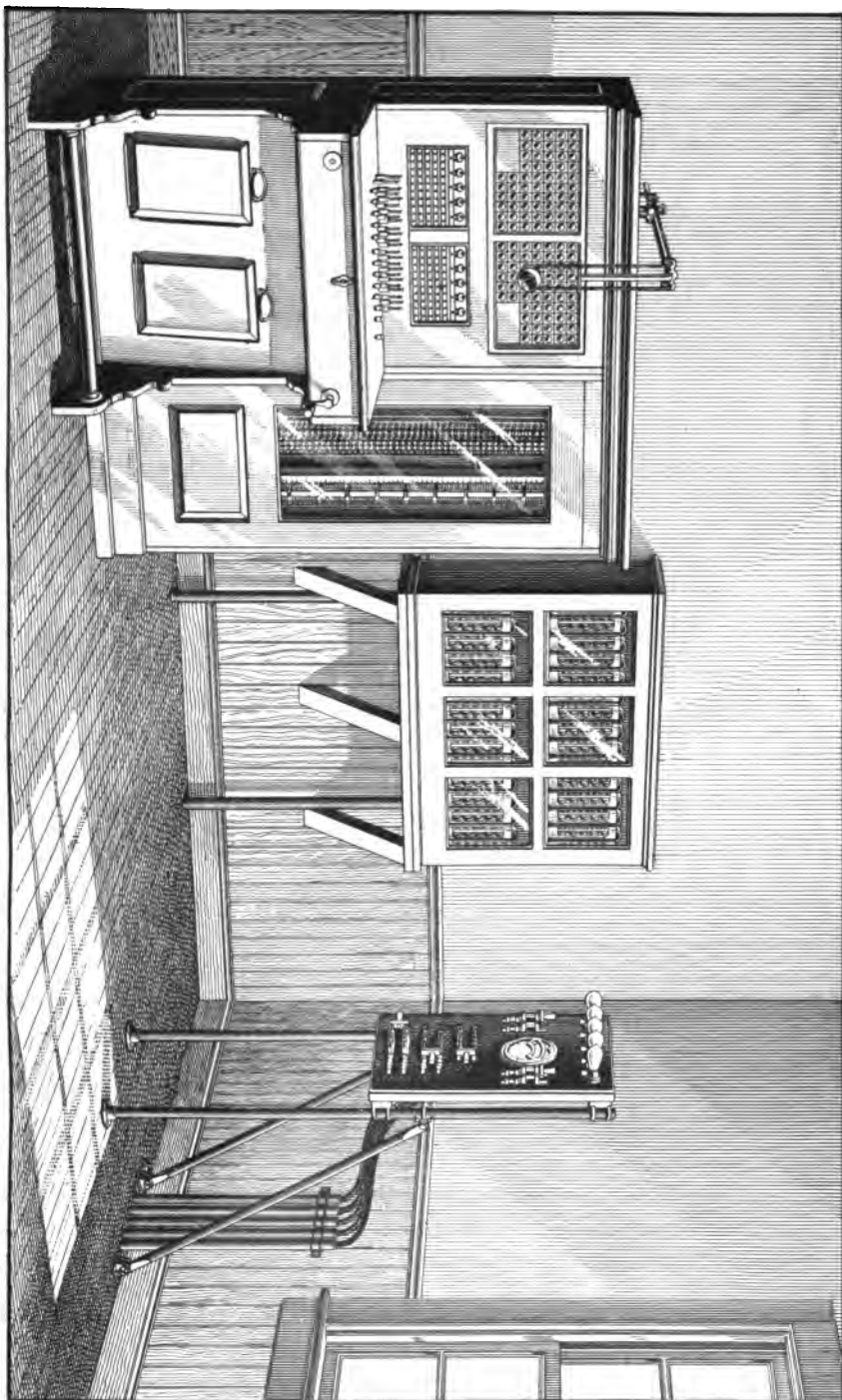

Fig. 108.—Ideal central office installation.

Figure 108 illustrates an ideal installation of the central office apparatus where direct current is available. A detail drawing of the charging panel shown is given in figure 18, chapter II.

These panels are intended for installation at about 18 inches from the wall, as indicated on the figures. The leads from the switchboards and the post power should be brought up from the floor in loricated conduit fastened to the wall, even with the bottom of the panel; from this point the lead sheath is removed and the wires are carried over to the connecting lugs on the rear of panel. The exposed parts of the leads should be painted thoroughly with preservative paint. If the storage battery cabinet is near by the leads, it can be carried directly to it; but if any considerable distance separates these apparatus their battery leads should be lead down to the floor and then to the battery cabinet in the same manner as to the panel.



FIG. 109.—Switchboard protective apparatus, heat coils and lightning arresters.

As stated previously, lead covered cable should be used for the leads, the lead sheath being cut back at the end for connections. Where alternating-current power circuits are installed care must be taken to install both wires of the incoming power circuit in the same loricated iron conduit.

Instructions for installing the storage battery are given in Chapter II. Where the cells are installed in a cabinet, care should be taken to erect the cabinet in a permanent manner, keeping in rear the weight to erect the cabinet in a permanent manner.

Where alternating current only is available, necessitating the installation of a motor generator, this machine should if possible be installed in a closet nearby or in some place easily accessible from the switchboard room. However, in case of necessity it can be installed in the switchboard room, as the noise when in operation is so little that it will not interfere with the operator.

MAINTENANCE OF TELEPHONE SWITCHBOARDS.

The first essential for maintaining a telephone switchboard is a familiarity with the circuits and the functions of the apparatus comprised in them. The unlimited variety of defects and faults that can develop make it impossible to take up in detail all the conditions that will have to be met, so that only a general discussion of them will be attempted. These defects may be divided into two classes: Those where the apparatus fails to operate or perform the mechanical functions they are designed for and intended to meet, aside from the transmission of speech; and, second, the failure to transmit speech at all, or only in an inefficient manner. However, the possible causes for either condition are so related that it is difficult to outline specific methods of removing any case of trouble.

The first principle in correcting trouble in any electric circuit is to localize it. In a telephone switchboard, trouble in any circuit should be located by disconnecting component parts of the circuit after tests have been made at each step. A vacant line jack from which the line signal has been disconnected should be connected to one or two dry cells for the tests of cord circuits of magneto switchboard. For a central energy board, the jack can be connected to a low resistance. By inserting the plug, test of the condition of a cord circuit can be made. To ascertain if the cord itself is in trouble, the plug should be inserted and the cord moved violently, and if a partial short circuit or open in the conductors is present it will be indicated by the grating noise in the operator's receiver. An open cord is indicated by the "deadness" or lack of resonance in the operator's receiver. A test of the generator or ringing circuit can be made by ringer on this line, and the buzzer provided will indicate the condition, as stated in another paragraph. The supervisory signals can also be tested in this manner. The greatest amount of trouble in telephone switchboards of the types furnished by the Signal Corps will develop in the connecting cords, as these are subjected to the greatest usage, and most liable to injury. Next to the cords, the ringing and listening keys and the line jacks will require the most attention. A failure of any piece of apparatus to operate mechanically will naturally require an examination of that instrument to ascertain its mechanical condition first. However, if the fault lies outside the apparatus, an unusual condition of the circuit is causing the trouble, and to locate it will require a detailed test, using the localizing methods recommended. Figures 93 and 95 show the cord circuit of a common battery telephone switchboard and indicate the color of the insulation on each conductor of each circuit, which will aid in the work of testing the circuits.

Another source of trouble in telephone systems is what is known as "cross talk." As its name indicates, it is a condition where the conversation over one cord circuit is heard on others which normally should have no connection with it. This fault, however, should always be removed when the switchboard is installed, and the development of cross talk in a system during operation is always due to alterations in the mechanical and electrical conditions of the apparatus. "Cross talk" is due to either a common resistance, which can be caused by the contact of parts of circuits which should not be in contact, or as a result of electrostatic or electromagnetic induction. Owing to the nature of the circuits in the telephone switchboard, the electrostatic effects may be ignored in the consideration as to the probable cause of a trouble which it is desired to remove.

The first step is to localize it into the switchboard by disconnecting the outside lines. If it is still in evidence, the switchboard is at fault. A common way to test for "cross talk" in the central equipment is for the operator to try to hear the conversation on a cord circuit by listening on cords not in use.

"Cross talk" may be caused by the inductive effect of parallel wires or adjacent parts of the switchboard equipment, such as supervisory signals, relays, etc., which are not provided with metal cases. This can be localized more easily than any other trouble, and should be the method pursued. As stated previously, the battery leads to the central energy switchboard should be sufficiently large to reduce the common resistance to the circuit to an amount where it would be a very small factor in the resistance of the telephone circuit after established. In addition to this the condenser bridged across the bus bars in the switchboard reduces the amount of cross talk from the battery leads. It has been found that reversing the relative position of the unsheathed windings on the answering and calling supervisory signals removes "cross talk" which is probably caused by the inductive effect of these coils on the adjacent signals. Relays are usually provided with metal covers to overcome this fault. The lacing on the forms of the telephone switchboard should never be cut except as a last resort, and no disconnections of permanent wiring made until recourse to every other method has been tried.

Circuits can be segregated by inserting paper between connecting contacts of keys and testing each section of the circuit with a dry battery and buzzer or telephone receiver. In this way an entire circuit can be inspected and tested section by section without injury to the switchboard, and this should be done.

CHAPTER VII.

LINE CONSTRUCTION.

Lines constructed by the Signal Corps are of three general classes, namely, open wire, aerial cable, and subterranean. The construction of these classes of lines will be treated under separate headings.

OPEN-WIRE LINES.

POLES.

Poles should be preferably of red cedar, black locust, or heart of yellow (pitch) pine. Should these not be procurable, or only at too great cost, recourse may be had to other kinds of timber, such as chestnut, redwood, white cedar, red cypress, yellow cypress, tamarack, fir, larch, spruce, white or post oak, sassafras, and others, from which good service may be expected.

All poles shall be of the first quality of live green timber, free from rot, and sound and substantial in every respect. Each pole should contain the natural butt of the tree and have an approximately uniformly decreasing cross section from butt to top.

All poles shall be cut between November 1 and March 1, and shall be free from all bark and soft wood. All knots shall be trimmed closely and smoothly. The sizes and dimensions of poles shall conform to the table below.

When octagonal poles are ordered they shall be of the same material as specified for standard poles, and shall conform in general to the dimensions of the table.

Dimensions of poles.

Length of poles.	Circumference.	
	At top.	At 6 feet from bottom.
<i>Feet.</i>	<i>Inches.</i>	<i>Inches.</i>
20	14	24
20	16	25
25	16	25
25	19	27
25	22	30
30	19	30
30	22	34
30	24	36
35	22	37
35	25	40
40	22	40
40	25	43
45	22	45
45	25	46
50	22	46
50	25	48

Guy stubs and anchor logs.—The timber used for guy stubs and anchor logs shall conform in all respects with that specified for poles. Anchor logs shall not be less than 24 inches in circumference nor less than 4 feet in length.

Guy stubs shall not be less than 22 inches in circumference.

The timber to be used for pole braces shall be of the same quality as that specified for poles. Braces should not be less than 18 inches in circumference at smaller end.

NUMBER OF POLES.

The number of poles to be provided depends upon the character of the country, whether open, timbered, prairie, hilly, mountainous, etc.; upon the roads, whether crooked or straight; and upon the number of wires or cables to be carried. No less than 25 poles per mile must be used; but in timbered country, with crooked roads and heavy leads, it may be necessary to increase the number to 40, or even more in special cases.

PREPARATION OF POLES.

When practicable, the poles must be cut while the sap is down, and the bark removed, and allowed to season before they are placed in the line. This increases the durability of most kinds of poles and facilitates their transportation and erection. The tops of the poles should be roofed so that they will completely shed rain and snow, as shown in figure 110.

LIGHTNING RODS.

A lightning rod should be provided for every fifth to tenth pole of all aerial lines. This rod may consist of a piece of No. 6 galvanized iron wire extending not less than 12 inches above the roof of the pole and attached to the sides thereof by means of staples about 1 foot apart. The lightning rod should extend continuously down the entire length of the pole and may be soldered to a ground rod driven into the earth near the base of the pole or may be continued to the base of the pole and there end in a small coil of wire, to give good surface contact with the earth. This rod should be kept as straight as possible without turns or coils in its length and should be installed before the pole is erected.

CROSS ARMS.

The standard cross arms supplied by the Signal Corps are indicated in the following table:

Dimensions of standard cross arms.

Length in feet.	Number of pins.	Pin spacing.		
		Ends.	Sides.	Centers.
3	2	4	28
4	4	4	12	16
6	6	4	12	16
8	8	4	12	16
10	10	4	12	16

INSULATORS.

The standard insulator is the pony-glass insulator, either single or double groove. Special cases may require the use of a heavier insulator, but, in general, the above type will be found suitable.

WIRE.

Wire for short lines and lines not subject to deterioration from rust is of galvanized iron of the grade known as "Extra Best No. 14, B. W. G." For long lines through rugged country or for telegraph purposes or where extra strength is required, No. 9 galvanized iron wire is suitable. Where lines are exposed to the action of salt air or for common battery telephone work, especially on comparatively long lines, No. 14 or No. 12, B. & S. gauge, hard-drawn bare copper wire is furnished. This wire is supplied in coils of 1 mile and should be handled with extreme care to avoid bruising or scratching its surface. Any scratch or bruise made should be cut from the wire before it is installed. Splices should invariably be made with copper splicing sleeves furnished especially for this purpose. Joints should not be soldered. Tie-wires for fastening the wire to the insulator should be of the same gauge as the line wire and annealed before using.

All line wire shall be strung from pay-out reels in such manner that it shall be free from kinks or twists. For copper wire, Buffalo grips should be used so that it will not be injured. For galvanized iron wire, either a Buffalo grip or other form of clamp may be used. Wires are to be strung with a uniform sag, so that all the wires on a cross arm shall be even and level except where sizes vary.

ERECTION OF LINE.

The route of the line having been decided upon and the materials prepared or procured, a competent person must proceed to measure the distance and indicate, by stakes, the places at which poles are to be erected. When the line follows highways or other defined routes, he will necessarily be governed by the bounds of such route, and must place his stakes within those bounds and in such a manner as to avoid, as far as possible, danger to the line from passing vehicles.

As a general rule in open (unfenced) country, where the ground is practicable for wagons, the stakes may be run in straight lines, but where there is a well-defined and traveled road the line of stakes must follow the general direction of such road and be set at such distance from it that the line when completed shall not be exposed to injury from passing vehicles, or, in case a wire should become detached from the insulators, it can not by any chance hang in the road and interfere with or endanger traffic. With this in view, the line must be so placed as to be readily inspected and examined by repair men from the road. Whenever practicable, the line should be removed from the road a distance of about 30 feet. Roads should never be crossed unless necessary to avoid bad ground or trees which

are too numerous to cut away, or to make material saving by shortening the line. Such crossings should be made at half a right angle. In rolling country poles should be planted near the crests of hills and not on each side, as in the latter case the wire will not be raised sufficiently high above the ground to be free from danger of being broken by passing herds or vehicles. As far as practicable grade the line by using the longer poles in hollows and the shorter ones on high ground.

In level country poles may be set at the rate of 30 to the mile for light leads. This distance may be increased when the configuration of the ground renders it necessary, as in crossing streams, ravines, etc. In hilly, rolling, and timbered country, especially with crooked roads, it will be necessary to increase this to 35 poles to the mile, or in special cases to 40 or more.

At all crossings the distance between poles should be shortened and the height of wire above crown of road be not less than 18 feet.

DIGGING HOLES.

The depth to which poles should be set depends upon the character of the soil in which they are placed, the height of the pole, and the load it is to carry. In rock, gravel, or stiff clays a less depth is sufficient than in light loam or sand. The following table gives the depths for average conditions:

Length of pole.	Depth in ground.	Depth in solid rock.
<i>Feet.</i> 18	<i>Feet.</i> 3 ^a	<i>Feet.</i> 3
20	3½ ^b	3
22	4	3
25	4	3
30	5½	3½
35	6	4
40	6	4
45	6½	4½
50	7	4½

^a On straight lines.

^b On corners.

A foreman follows the surveyor with a sufficient number of men equipped with digging bars and spoon shovels (particularly well adapted to digging in light soils), the ordinary long-handled shovel, which is more easily procured, or post-hole diggers, where the soil will admit of their use. This party digs the holes for the poles as marked out by the stakes. If there is a sod, one of the men, equipped with an ordinary spade, may be sent ahead to remove it, indicating the size of the hole to be dug, and facilitating the work by performing a part thereof for which the bars and spoons are not well adapted. The foreman must see personally that the holes are put down to the proper depth and are of the same size at the bottom and top. He will have direction of the force and be held responsible for good

service. For poles at crossings, curves, and long spans the holes must be dug to a depth corresponding to the strain to be brought upon them.

DELIVERY OF POLES.

The poles should be delivered as soon as practicable after the holes have been dug, with the butt of the pole by the hole and the top in the direction from which the raising party will come. No equipment is necessary for this labor, except the means used for the transportation of the poles and carrying hooks with which to move them as required after unloading. For crossings and long spans the heaviest and longest poles should be selected; for angles and sharp curves, select the stoutest.

FRAMING POLES.

All poles carrying cross arms should be framed in the following manner: Raise the pole at the top and place it in a framing buck or horse so that the heaviest sag or curve will be nearest the ground. If the pole be crooked or badly shaped, it should be turned with a cant hook until the best side for framing is uppermost and the pole held rigidly in place. In this position the pole should be roofed. After the roofing has been done, the gains should be cut. These may be leveled with a straightedge or sighting stick. To bore holes for cross-arm bolts, a line should be set off from the center of the top of the pole to the center of the butt and the bolt-hole center laid off along this line. A half-inch hole for steps may be bored at right angles to the line or in line with the cross arms, beginning 18 inches from the lowest cross arm and continuing on opposite sides of the pole until a point 8 feet from the ground is reached.

All cross arms for carrying four wires and upward must be braced. (Fig. 110.) Gains on cross arms will not exceed in any case $1\frac{1}{4}$ inches in depth.

The distance from the upper side of the top gain to the extreme top of the pole will be 8 inches, and the distance between gains from center to center 2 feet. Cross-arm braces should be attached to the face of the pole and to the face of the arm. Two lag bolts will be used in all cross arms which are not braced. Cross arms must be placed on opposite sides of alternate poles, except where special conditions of line wires may require otherwise.

Cross arms should be set at a level at right angles to the pole length and not parallel to the ground. This applies as well to corner poles, no matter what the degree of rake. The spirit level should never be used for leveling cross arms.

The use of buck arms is not allowed under any circumstances.

Cross-arm fixtures should, if practicable, be attached to buildings, with bolts passing through the wall. If this is not practicable, large expansion bolts should be used. Window casements or woodwork of buildings should never be used for resisting the strain of the line.

Poles shall, wherever possible, be armed before they are erected.

In figure 110 are shown the methods of attaching cross arms for leads not exceeding four wires; (a) shows the four-pin cross arm, with braces; (b) the two-pin cross arm attached with lag bolts; while (c) and (d) show the methods pursued in the case of iron poles.

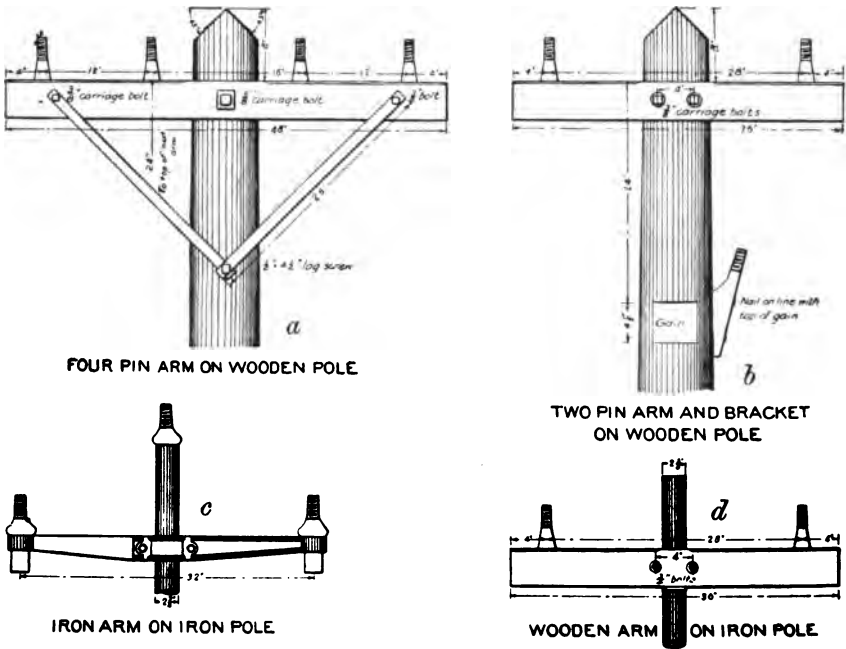

FIG. 110.

These iron poles are only used occasionally to meet special conditions, and are not suitable for carrying more than four wires and should only be installed in hard earth or concrete.

For straight lines, the wires should be placed on the insulators as shown in figure 111a. It will be noted that all wires are on the pole

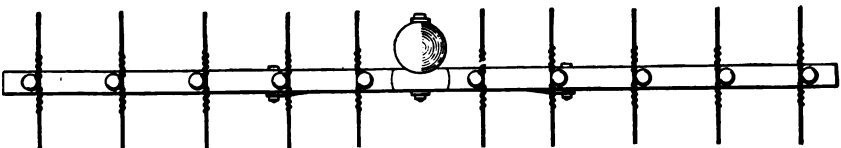

FIG. 111a.—Method of placing wires on insulators.

side of the insulators, except the middle pair, which is placed on the outer side to provide a greater separation. On corner poles all wires should be placed as shown in figure 111b.

The approved methods of tying the line wires to the insulators are shown in figures 112 and 113. It will be noted that the methods for

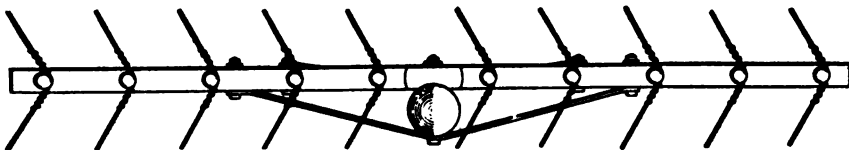
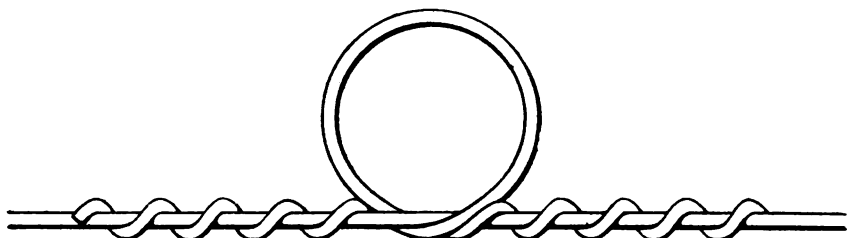
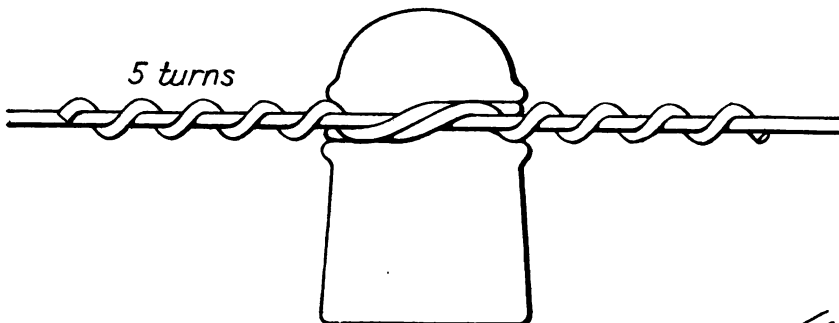

FIG. 111b.—Method of placing wires on insulators.



Top view of tie without insulator



Complete tie

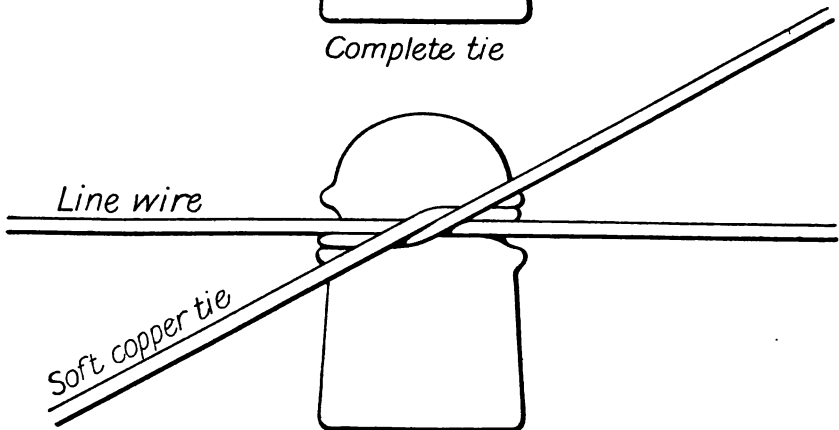

Commencing tie - Ready for wrapping

FIG. 112.—Method of tying copper wire to insulator.

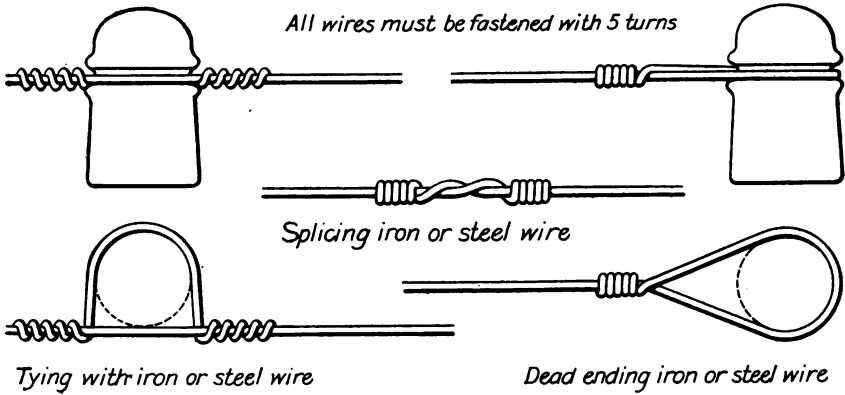

FIG. 113.—Method of tying, splicing, and dead ending iron and steel wire.

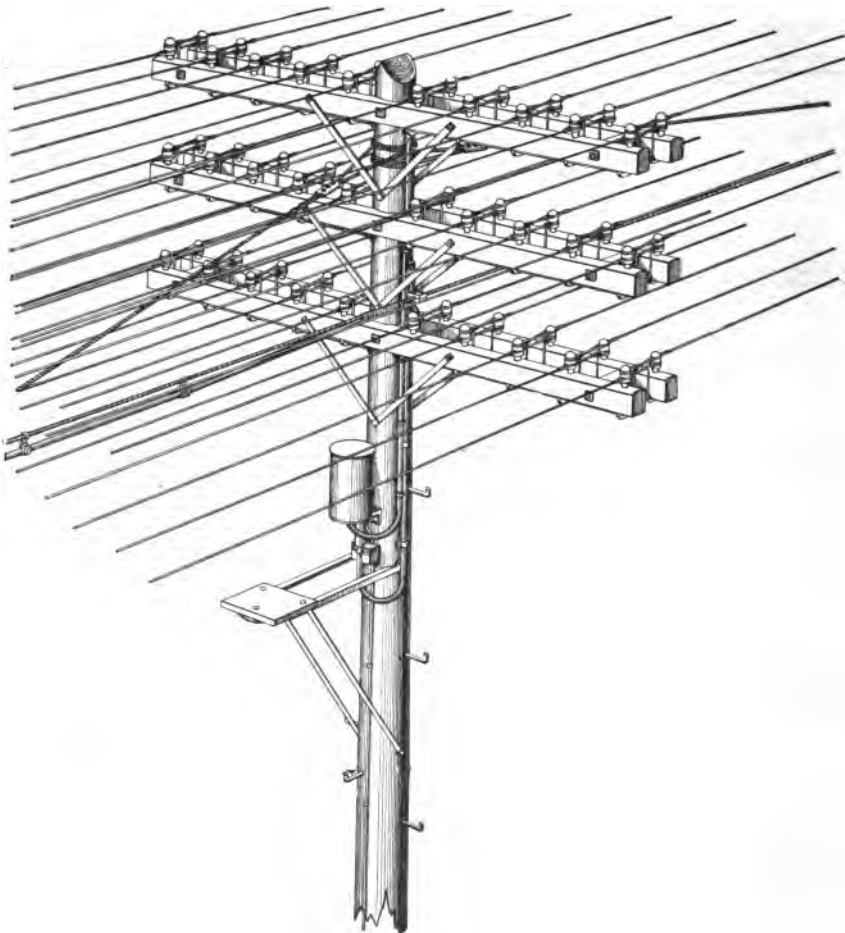

FIG. 114.—Office pole.

iron and copper wires are different. Soft copper ties should be used for copper and soft iron for iron or steel line. Care should be taken not to injure the wire in tying to insulator and at the same time a secure fastening should be made.

Double arms.—The approved method of installing double cross arms is shown in figure 114. The poles upon which the double arms are to be placed should be selected from the heaviest of those available, as these must bear an additional load, and extra strength should be provided. In figures 115*b* and 115*c* is shown the method of dead

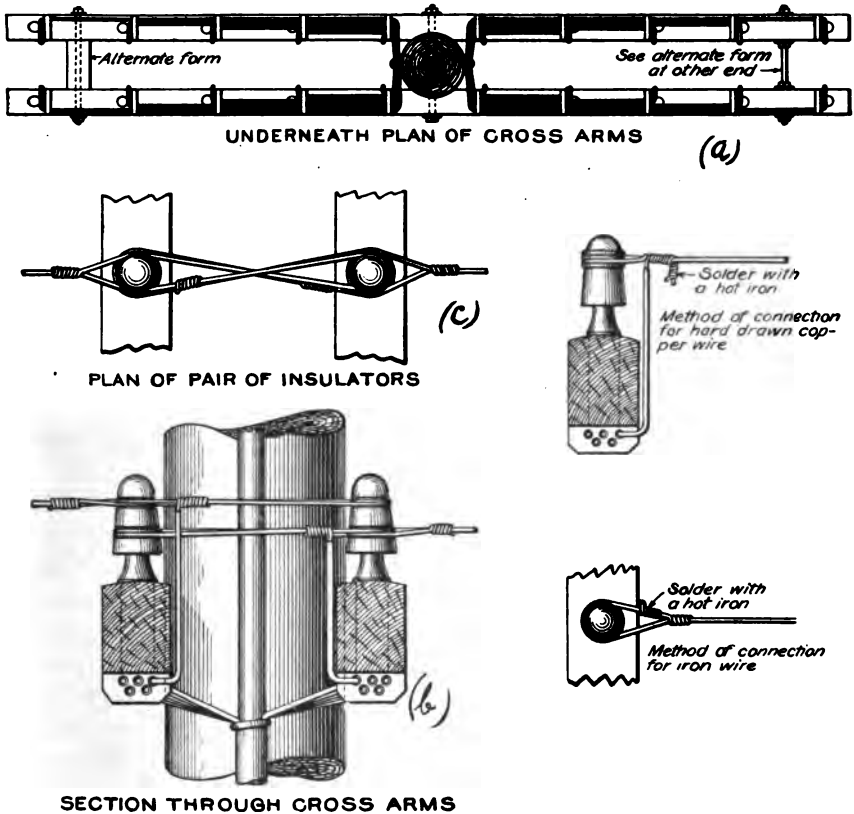

FIG. 115.

ending wires on double cross arms. Where the wires are not dead ended, but pass through, they will be tied to both insulators in the lower groove of the glass, if double groove glasses are in place.

BRACKET LINES.

Where not more than two wires are required on a pole line, oak brackets may be used in place of cross arms. The brackets should be attached to the pole with one 20d. and one 40d. nail and, in general, should be placed as shown in figures 116*a* and 116*b*. Where brackets

are placed on poles which may be, at some later time, used to carry cross arms, the top end of the bracket should be about level with the top of the gain, so that the bracket and its wire will not interfere with the subsequent use of the cross arm.

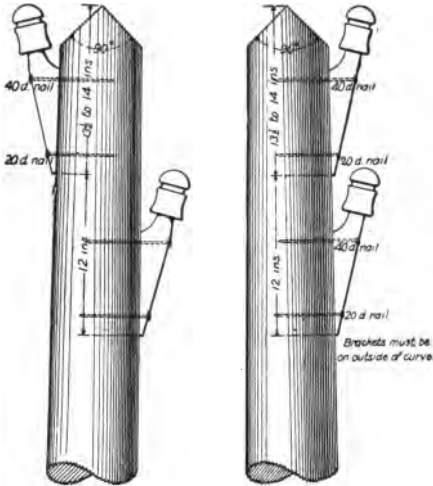

FIG. 116a.—Method of attaching brackets. FIG. 116b.—Location of brackets on curves and at corners.

OFFICE POLE.

The terminal or office pole of a line carrying a number of wires is the most important part of the line and demands careful attention to secure construction that will be serviceable and easy to maintain. There will be necessity for frequent access to this pole, so that all wiring should be substantial in character and arranged to facilitate repairs

and extensions. The office or terminal pole shown in figure 114 indicates the construction to be followed in the typical case.

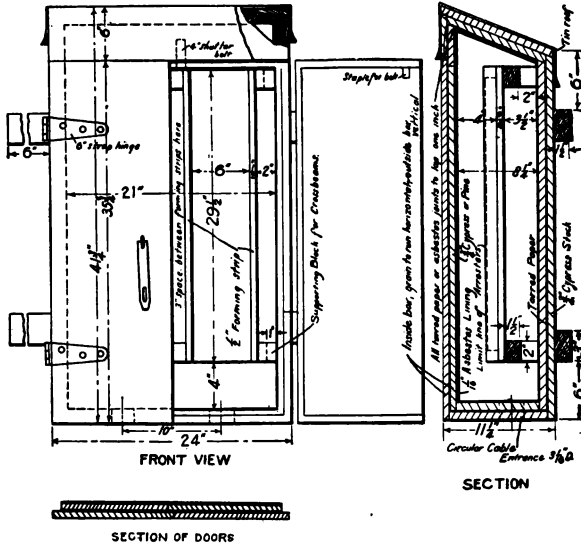

FIG. 117.—Cable box.

It is probable that the conditions shown in figure 114 will not be exactly duplicated in any construction work which may be taken up, but the methods shown should be followed as far as practicable.

The pothead terminal shown may be installed or use may be made of a cable box shown in figure 117. The latter is, in the general case,

considered preferable. It should be carefully attached to the pole as shown in this figure. In ordering these boxes the number of pairs to be accommodated should be stated as well as the number of pairs of lightning arresters or fuses. No aerial line should be connected to a cable pole or to a central exchange except through fuses and lightning arresters. The terminal or cable box poles should be stepped, using for this purpose galvanized iron pole steps, as shown on drawing. These iron pole steps should not come down to less than 6 or 8 feet from the ground. To reach these steps use may be made of a ladder, or brackets with the tops cut off may be fastened to the pole for footholds, as shown in figure 118. Bridle wires, which are used to connect the line wires with cable or exchanges, are shown in figures 115*a* and 115*b*, run in hard-wood cleats. Where these cleats are not available, a suitable size of enameled bridle ring may be used. Particular attention should be given to all wiring about the pole to see that it fits neatly and is so placed that it will not be injured by the workman in the performance of his necessary duties.

Where the wires which dead end on a double arm come from one direction only, it will be necessary to counter-balance the strain by running a small guy from this cross arm to the next pole.

Linemen should not use climbers on poles provided with steps unless such use is clearly unavoidable.

POLE SETTING.

All pole holes should be dug large enough to admit the pole without the necessity of cutting away the butt, and should allow space to move the pole about for bringing it into line. The size of the

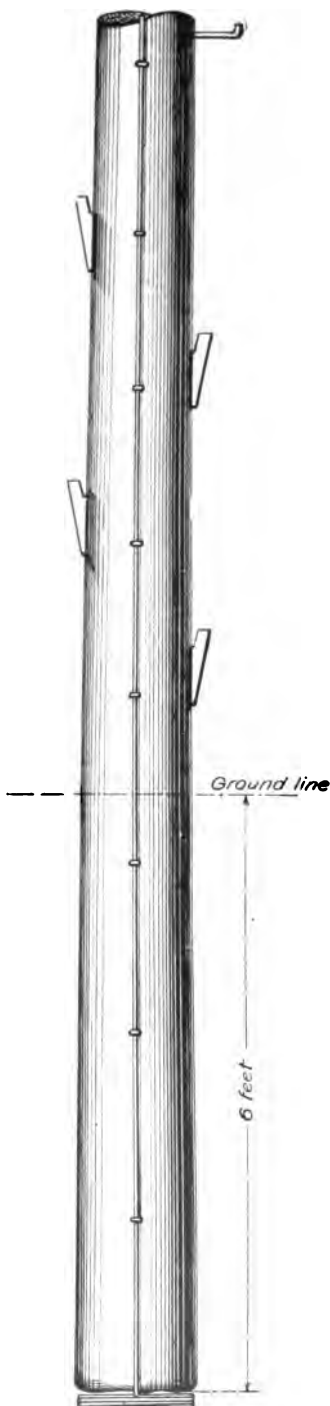

FIG. 118.

hole should be such that the tamping bar may be used full depth. This matter of thorough tamping as the hole is filled is important to the proper setting of the pole. On straight lines the cross arm should be placed at right angles to the direction of the pole line, the arms on adjacent poles facing in opposite directions. At line terminals the cross arms on the last two or three poles should be placed on the sides of the poles which face the terminal. On curves the cross arms should be placed on the sides of the poles which face the middle of the curve. On straight lines the poles shall be set vertically. It is advisable that the corner poles should be given a slight rake when set, varying with conditions, from 10 to 20 inches. After the pole has been placed in position, the hole filled, and the earth well tamped, the soil should be well banked up about the pole and firmly packed in place. This is to prevent a depression forming about the base of the pole, due to subsequent settling of the earth. In filling holes the coarse material, soil or gravel, should be used at the top of the hole. Where poles are set in rock the pieces should be wedged in firmly about the pole. It will usually be found that there are more or less pronounced curves in all poles. When setting the poles these curves should be so placed as to be least apparent when viewed from the direction of the line.

In grading poles to obtain uniform height of lead it is proper to cut the pole as a last resort only when shorter poles are not at hand. If the difference in height is only 1 or 2 feet, it may be taken care of by digging the hole deeper. When necessary to cut a pole, the butt and not the top should be cut.

GUYS AND ANCHORS.

Wherever a pole line makes a curve, turns a corner, or ends in an office or other terminal pole, particular attention must be given to the matter of proper guys and anchors. The following instructions cover the cases usually met with under ordinary conditions. The various methods of strengthening the line shown should be adapted as the occasion requires to meet special or unusual cases.

A bracket or other line carrying one or two wires will not require guys or braces except on corner poles where the angle with the straight line is more than 45 degrees, and at road crossings or terminal poles. Where guys are required it will usually be found that No. 9 iron or steel wire, galvanized, will be sufficiently heavy, used with a small deadman or 6-inch guy anchor. Curves of less than 45 degrees should be provided for by giving the poles the proper rake as specified above. For lines carrying not more than six wires, all poles which are more than 15 feet from a straight line connecting ad-

jacent poles on each side should be guyed. For a lead of this size, standard guy wire, one-fourth or five-sixteenths inch diameter, will usually be found sufficient, used with a 6 or 8 inch guy anchor or ordinary deadman. On lines carrying ten or twelve wires, all poles which are more than 10 feet out from a straight line connecting adjacent poles on each side should be guyed. For a lead of this size, guy wire should not be less than three-eighths inch, with not less than one 8-inch guy anchor or usual deadman.

Wherever a line makes a right-angle corner with two poles, the poles should be guyed as shown in (A) of figure 119.

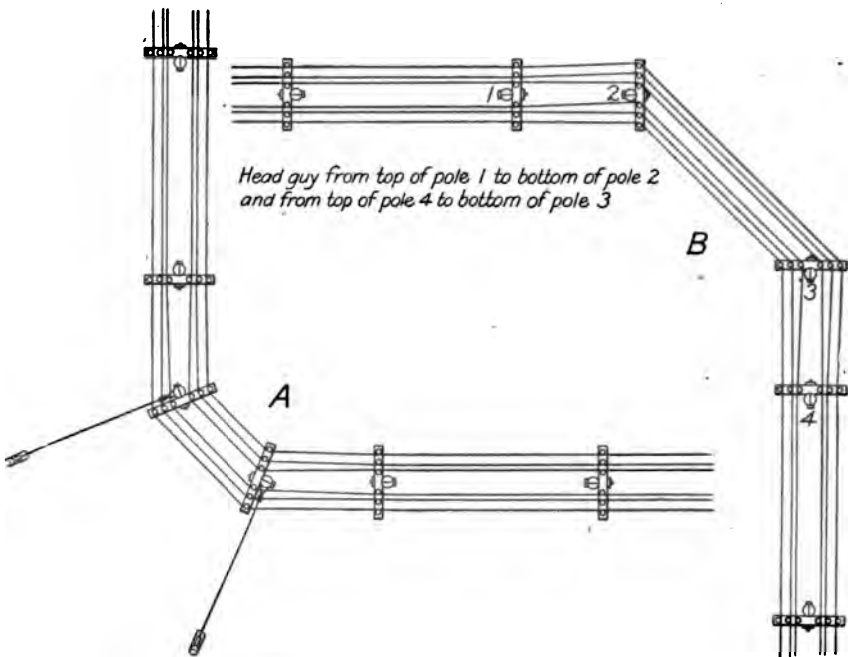

FIG. 119.—Method of guying at corners.

On straight roads where the line crosses from one side of the road to the other, corner poles should be guyed as shown in figure 120. Terminal poles on 20-wire lines having a span of 200 feet or more should be head guyed and, if possible, side guyed in both directions. When open-wire lines of 20 wires or more are dead ended in one direction only, the pole adjacent to the terminal pole should be head guyed.

The methods of guying on curves are shown in figure 121.

The above figures showing the methods of guying also indicate the sides of the poles on which the cross arms should be placed under varying conditions. In locating anchor guys the distance from the

butt of the pole to the eye of the anchor should not be less than one-fifth the length of the pole and, preferably, should be about the length of the pole. A typical "dead man" with anchor is shown in figure 122.

The anchor rod shown is of $\frac{5}{8}$ -inch galvanized steel. The rod passes through the anchor log and is held in place by a nut and square washer, as shown. The size of the anchor log will vary with the depth of the excavation. For an excavation of 5 feet in depth, the anchor log will be 5 feet long and 8 inches in diameter. For a shallow excavation a larger and longer anchor log should be used. The anchor log, after being placed in the excavation, should be cov-

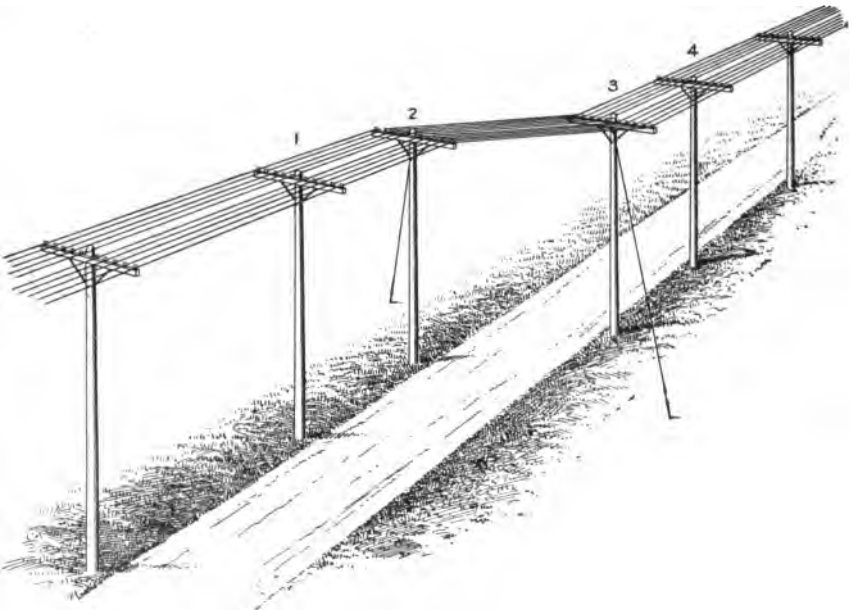

FIG. 120.—Line crossing road.

ered with planking, as shown. If this is not available logs or rock may be used for the same purpose. Guys should be attached to the pole immediately below the upper cross arm or the lower bracket, as shown in figure 123. Where No. 9 or other solid wire is used for guys, the wire should be fastened at either end by wrapping the end about the main wire. Where stranded wire is used, the guys should be fastened at each end by means of an approved form of guy clamp, either one, two, or three bolt. A thimble should be used for attaching the guy to the guy bolt or guy rod. The end of the wire should be attached to the stub or pole and wrapped twice about this, the wrapping being held in place on the pole or stub by a staple, lag screw, or heavy nail.

The attachment of guys to tree trunks should be avoided, if possible. Where this is necessary, the guys should be fastened to the tree trunk as near the ground as conditions will permit, in order that the swaying of the tree under weather conditions will not affect the line. When it is necessary to attach a guy to solid rock, the method shown in figure 123 should be followed.

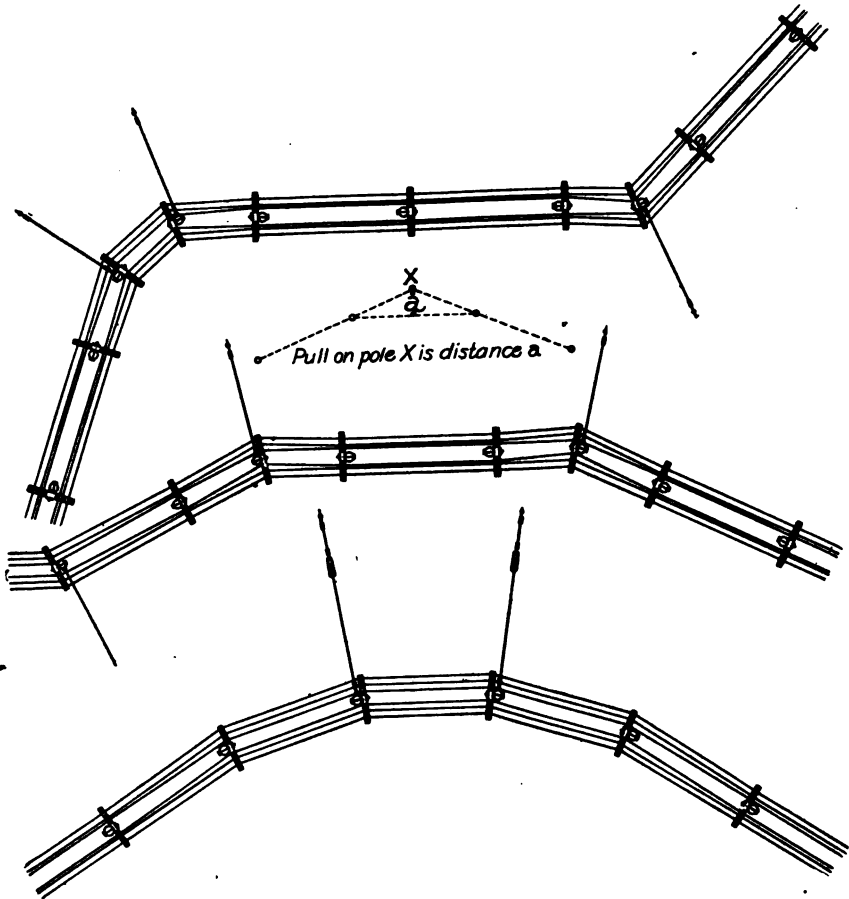

FIG. 121.—Method of guying on curves.

It may be found necessary in some cases to replace the guys shown by pole braces, although the latter are not considered as desirable a reinforcement as guys. Where pole braces are used, the butt of the brace shall be set at least $3\frac{1}{2}$ feet in the ground, on a firm support of planking, stone, or similar material. An approved method of installing pole braces is shown in figure 124.

Where it is necessary to raise guys over roadways or to clear obstacles, guy stubs should be employed, as shown in figure 125. The stubs

should have a top circumference of not less than 18 inches and should be set in the ground to a depth of at least 5 feet, and should lean away from the pole to which the guy is attached.

In general practice two turns of the guy should be made around each pole, one end of the block attached to the body of the messenger or guy and the other attached to the free end, the fall of the blocks passing back and down to the ground over a convenient stub or snatch block. All anchor guys, head guys, and corners should be pulled with two sets of guying blocks, one being used as a luff for the other set.

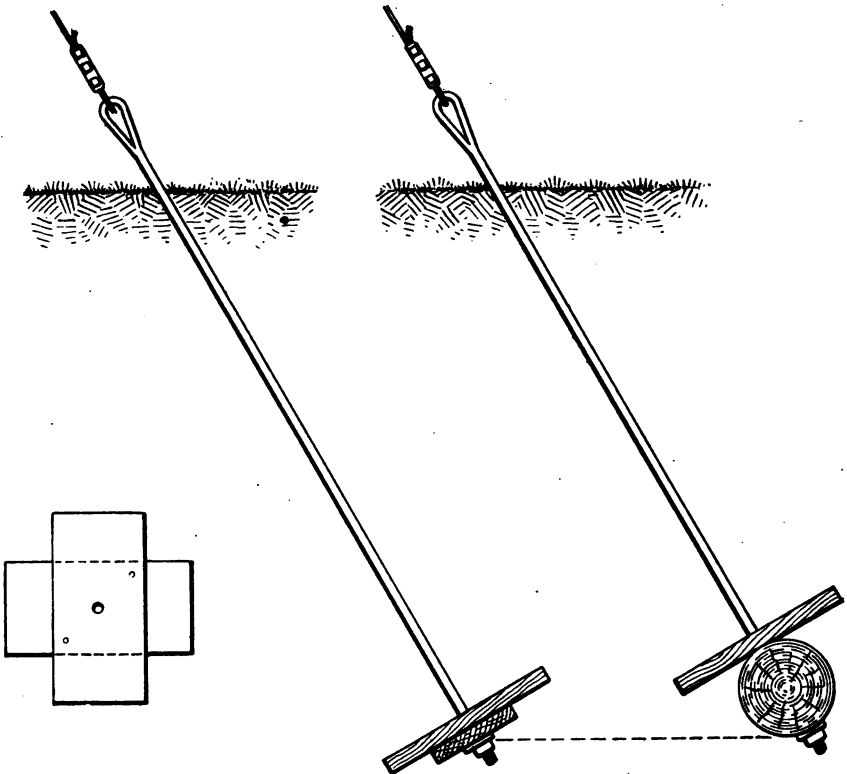

FIG. 122.—Deadman and anchor rod.

TRANSPPOSITION.

It may be found necessary in some cases to transpose a metallic circuit to prevent cross talk between telephone lines or interference from foreign circuits. In general, however, it will be found that the aerial lines installed by the Signal Corps are not of sufficient length to require transposition. Where it is necessary to transpose, the method shown in figure 126 should be followed.

In making a transposition the use of corner poles or curves should be avoided as far as practicable.

On long lines it will be found convenient to have a test station where the line may be opened and tested both ways for the location of trouble. A form of test station made on a two-piece transposition insulator is shown in figure 127.

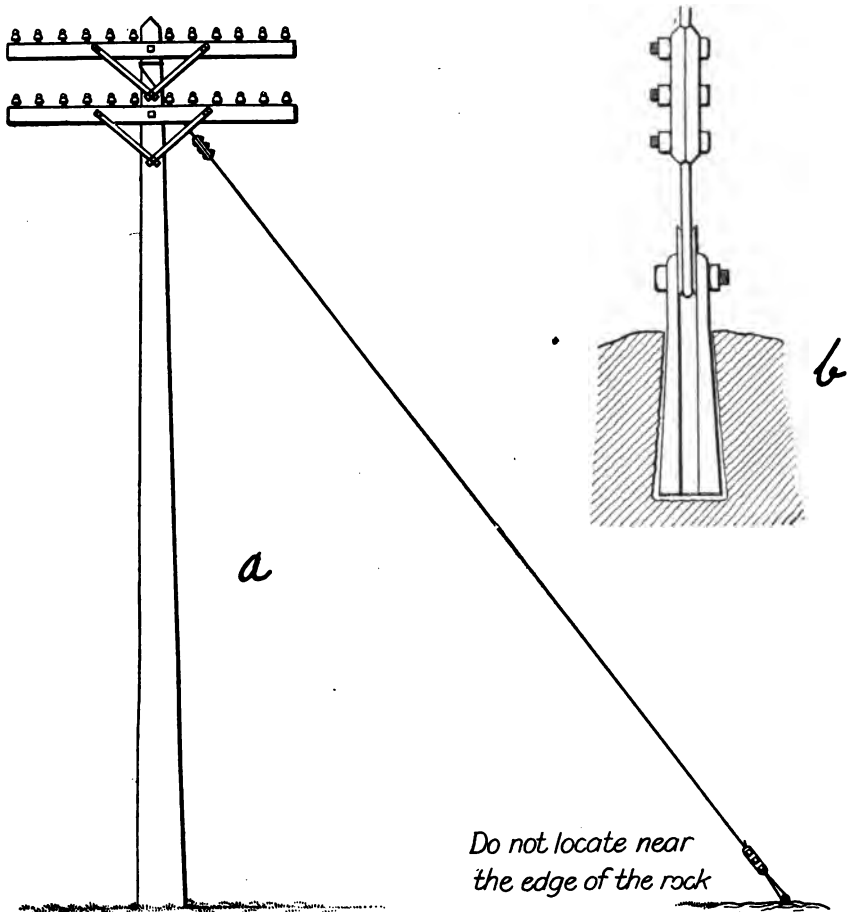

FIG. 123.—(a) Methods of guying.

(b) Anchor for solid rock.

GUARD WIRES.

Where guard wires are necessary to protect wires from other wires crossing above, they will be put up as described and illustrated below. Referring to figure 128, poles 1 and 4 should be framed so as to leave 1 foot of the pole above the top arm. Poles 2 and 3 should be framed in the regular way, with pin in ends of arms, as shown in sketch. The upper wires represent guard wires, which should be of No. 8 gauge

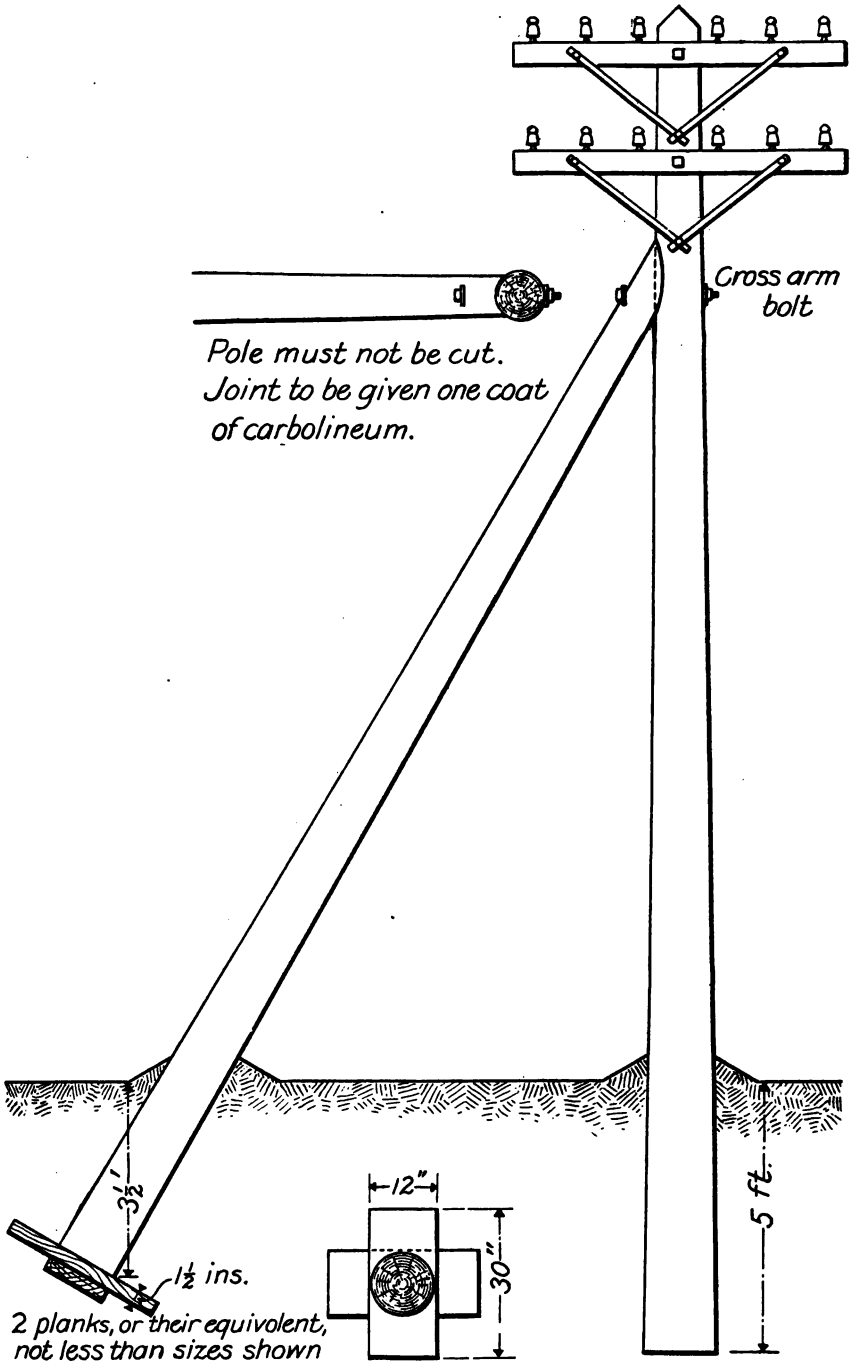

FIG. 124.—Pole brace.

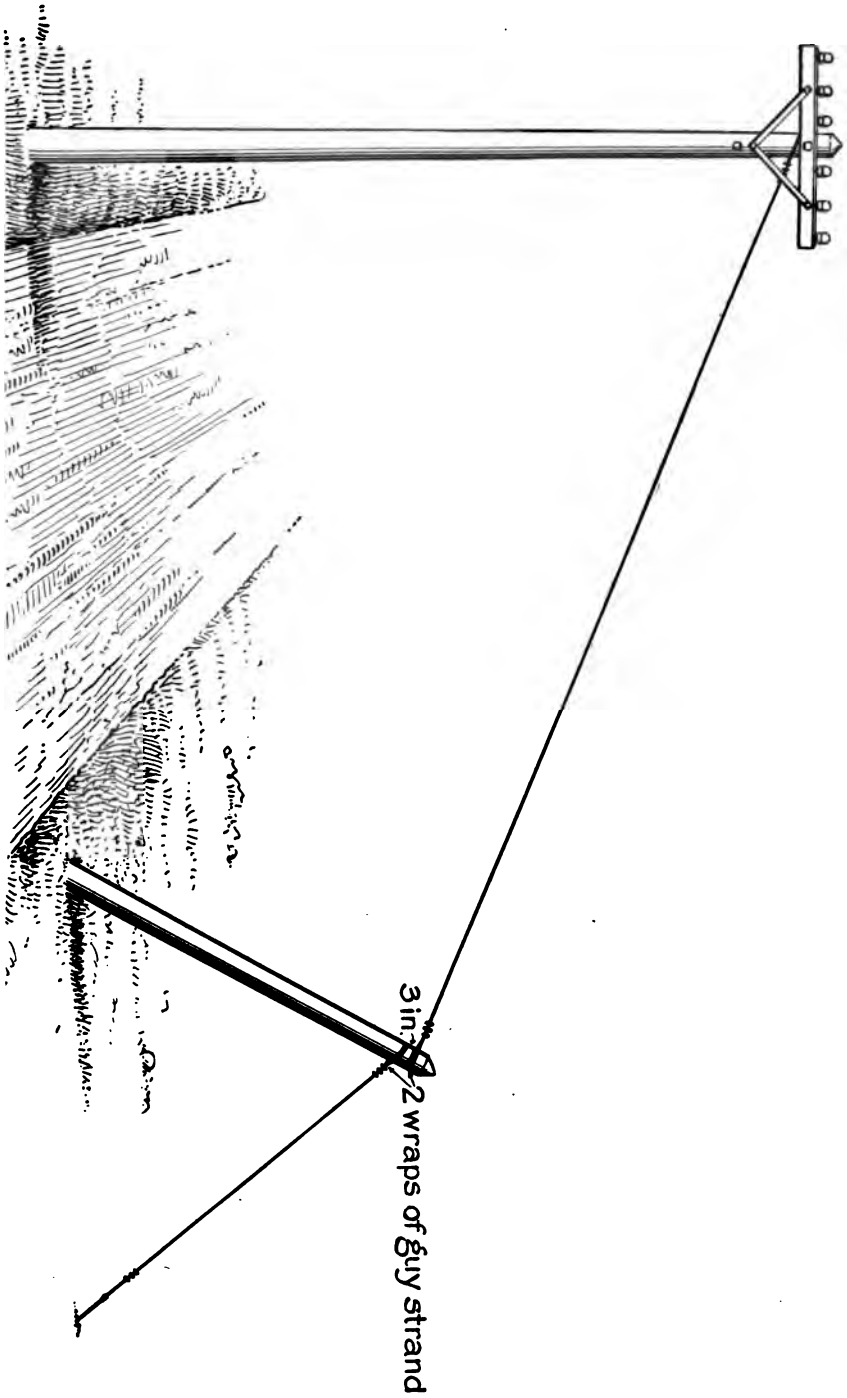

FIG. 125.—Method of rying across road.

where the crossing is under low-tension wires. Where the crossing is under electric-light, power, or other high-tension wires, standard guy wire or No. 4 wire should be used as guards.

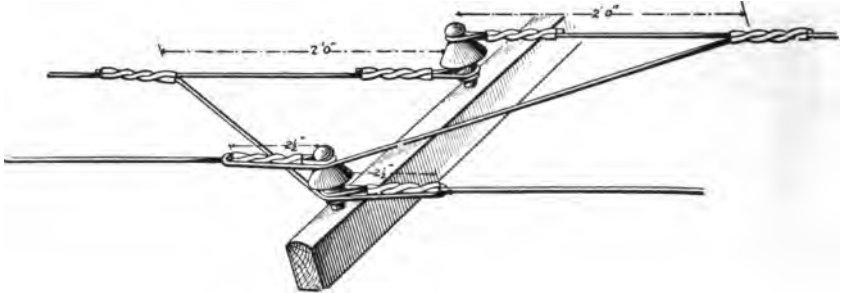

FIG. 126.—Line transposition.

The guard wires terminate on the top of poles 1 and 4, where heavy porcelain knobs or other circuit breaks should be used when the crossing is under high-tension wires. The straight lines show the working wires as they will appear after guard arms and wires are up.

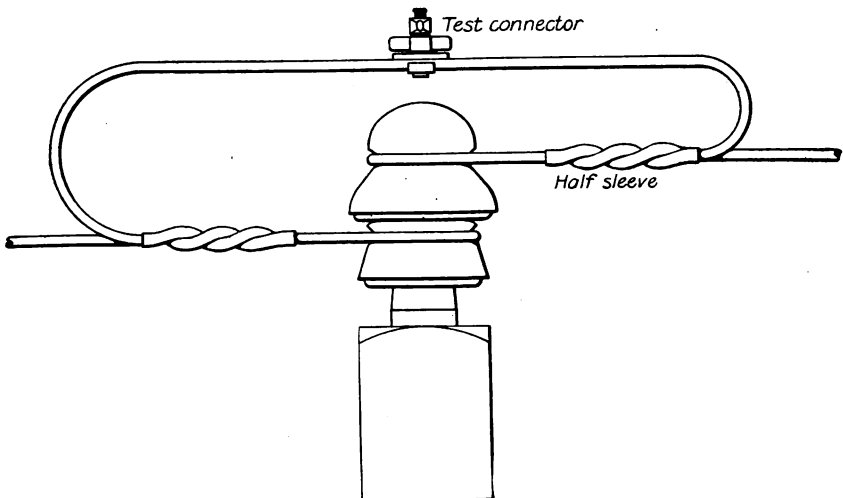

FIG. 127.—Test connector.

Where crossing under a heavy lead, and heavy guard wires are used, guy wires should be run from the top of poles 1 and 4 to a point 8 or more feet from the butt of the next pole to hold the strain of the guard wires.

NUMBERING POLES.

Distinctly mark with paint each twenty-fifth (or mile) pole with its proper number, from the initial to the terminal point of the section, to facilitate rendering reports and to enable repair men to report locations of repairs made and needed.

CLEARING AND TRIMMING.

Over right of way covered with trees or undergrowth, axmen must precede all others, except the surveyor, and clear the way for the work. When the line has been erected, they must follow and remove all branches or twigs which are liable to be thrown into contact with the wire, clearing back for a space of 4 or 6 feet, and removing all

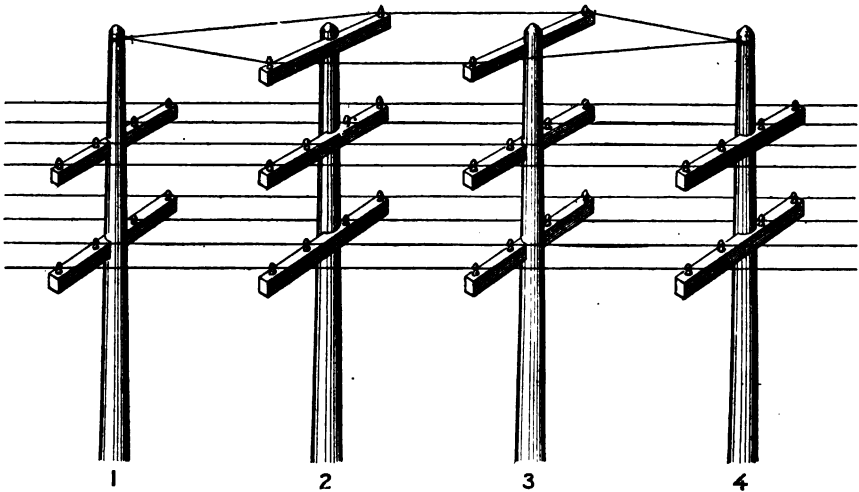

FIG. 128.—Guard wire.

dead branches, no matter what their distance, that might be thrown down by high winds and strike the line.

When the line passes through regions where it is liable to be injured by prairie fires, the sod should be broken and grass turned under to a distance of 10 feet from each pole. Officers in charge of telegraph lines running through such sections should send a party along the line each year to break the sod around the poles.

RIVER CROSSINGS.

When navigable streams cross the route of the line, it is usually the better plan to use cables, except where they are liable to be washed out by freshets; but if this method be for any reason impracticable, elevated supports must be used and the wire suspended above danger

from passing vessels. Natural supports, such as trees well rooted in safe positions, if such can be found of sufficient height, may be used, or masts erected and securely stayed with wire or wire-rope guys. If the span between supports be not more than 1,500 feet, the line wire can be used, care being taken to select the best, and a length without joints or with joints very carefully made. For greater spans a steel wire (or compound wire having a steel core) is necessary, with which spans upward of 2,000 feet can be made, provided the points of support are high enough to allow of a proportionately deep sag to the wire. Extreme care must be given to such crossings, and too great strain avoided.

CABLES.

In placing a cable across an inlet, stream, or other body of water it should be laid, whenever practicable, directly from the reel on which it has been received from the manufacturer. The reel will be rigged on a horizontal axle in the stern of a suitable vessel and paid out as steadily and regularly as possible. Especial care is necessary to prevent kinks, and to cause the cable to lie smoothly on the bottom. The shore ends of the cable should be buried sufficiently deep in trenches to protect them thoroughly from exposure to the air and injury from vessels, wheels, etc., and must be covered with stones or rocks of sufficient weight to keep them down, and prevent the earth from being washed away. The ends should be carefully secured to the cable pole in such manner that the pole will serve as a buoy in case of the washing away of the pole. Lightning arresters must be used at both extremities of a cable, placed in the cable boxes. These boxes should be made of well-seasoned pine thoroughly painted. The door to be hung with strong hinges, and the whole box waterproof when closed. The cable end is brought up into the bottom of the box as shown in figure 129. This opening should fit as closely as possible to prevent access of moisture, insects, etc.

The line wire must then be connected by a piece of bridle wire to the binding post at the fuse end of the lightning arrester. The cable should be connected to the binding post at the other end of the arrester. The ground terminal of the lightning arrester must then be tested to make sure that no ground exists between the coils and the ground plate. The door should be provided with a type of rust proof Yale or Corbin lock. The cable from the ground to the box should preferably be inclosed in an iron pipe, but where an iron pipe is not available a wooden box may be substituted. All cables should be anchored, using a log buried in the ground below the permanent moisture line. Enough slack cable should be provided beyond the point of attachment to the log to permit paying out in case the cable

has been caught by anchors and drawn taut. Anchoring should never be omitted unless the body of water crossed is not liable to floods or is not navigated by boats carrying anchors. (See fig. 129.)

HANDLING HARD-DRAWN COPPER WIRE.

While hard-drawn copper wire possesses hardness and strength for all practicable purposes, it will not stand without injury the rough handling to which iron wire is ordinarily subjected.

Every coil should be examined before the outside cover is removed. In case the covering is torn, the wire itself should be carefully in-

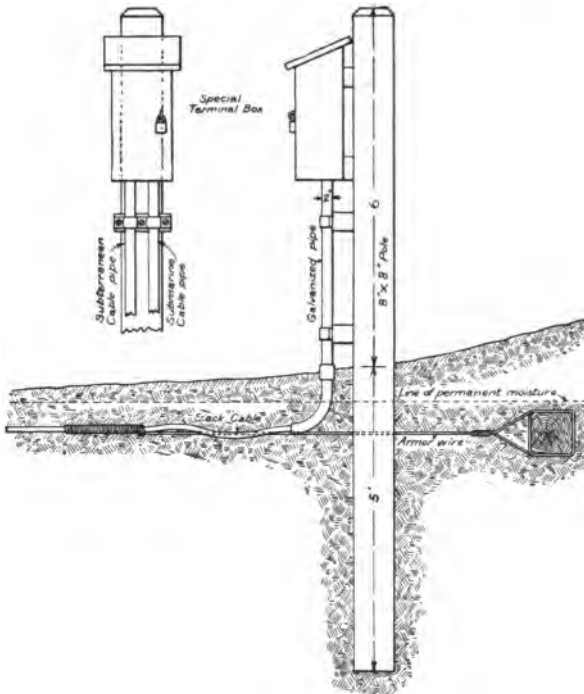

FIG. 129.—Cable box.

spected to see that it has not been cut or bruised. In case the wire is found to have sustained injury, the injured portion should be cut out before using.

Copper wire should never be thrown from a wagon or train.

While unreeling, great care must be taken to avoid twists and kinks. Wherever either is found, it must be cut out and a good splice made. This applies also to splits, bruises, or indentations of any kind.

In tying the wire, care must be used not to tie it so tight as to cramp or kink it between the tie wire and the glass. Hard-drawn copper wire must not be tied with any wire other than soft copper.

When once hard-drawn copper wire is carefully put in place without kinks, indentations, or bruises, it will stand changes of temperature, sleet storms, etc.; practically as well as iron or steel wire of much lower conductivity.

Combination splicing clamps and Buffalo grips are used for handling this wire.

STRINGING WIRE.

After the pole line has been completed, with all guys, anchors, etc., in place, the stringing of the wire should next be taken up. The working party for this purpose will comprise a foreman; a sufficient number of linemen, varying from 2 to 6; one or two ground men; and such means of transportation as may be necessary. The linemen are equipped with tools for splicing wire and for attaching it to the insulators and must be men who are able to climb poles and work to advantage thereon. Where iron wire is being strung for long distances for telegraph work, it is desirable to solder all joints. This can best be done by dipping the joint when completed in a pot of melted solder. For short iron wire lines, and for copper wire, joints need not be soldered. Iron wire should be tied in with soft iron wire of the same size as the line wire. Copper wire should be tied in with pieces of soft copper wire of the same size as the line wire.

Having provided the working force with the necessary tools, a coil of wire is placed on a payout reel, the binding wires removed, and the outer end of the wire attached to the starting point. The wire on the reel is then carried along as near the line of poles as possible so that the wire will run out straight and in a convenient position for carrying up. When a sufficient amount of wire has been run out, it is carried up by the linemen and placed in a loose tie on the insulator. The ground men then pull the wire up to the proper tension, after which the tying in is completed, and the linemen descend. In other cases it may be found advisable to keep the payout reel stationary. In such cases the wire or wires are attached to a long lead rope, which is carried up and passed over the cross arm. Where this method is pursued, it is desirable to place the full length of the coil on the poles before proceeding to tie in.

TOOLS.

The following list includes tools which have been found necessary in the construction of telephone and telegraph pole lines. In making requisitions for tools for any piece of work this list should be followed as closely as possible, as the items listed therein will usually be found in stock at supply depots or may be purchased in open market without great delay:

BUILDING TOOLS.

- Adz, house carpenter's, full-head, 4-inch blade.
Ax, hand (specified as broad hatchet), 5-inch blade.
Axes, handles for, to be hickory, clear, straight-grained.
Ax, lineman's, 5-pound, long-handle, all-steel.
Bags, linemen's, best canvas, with leather bottom, 20-inch.
Bars, crow, wedge-point, 17-pound, best tool steel.
Bars, digging, 1-inch round, 8 feet long, weight 17 pounds, and $1\frac{1}{2}$ inch round, 8 feet long, weight 28 pounds; both to be of solid steel.
Bars, digging and tamping, 1-inch round, tool-steel, 7 feet long, weight 19 pounds; 1-inch octagonal, tool-steel, 8 feet long, weight 25 pounds.
Bars, digging (electric spud), steel tubing with cast blade and tamper.
Belts, lineman's, for tools, 38, 40, and 44 inch, with loops, rings, and safety strap.
Bits, auger, sizes $\frac{1}{8}$, $\frac{1}{4}$, $\frac{3}{8}$, $\frac{1}{2}$, $\frac{5}{8}$, and $\frac{3}{4}$ inch, all 8 inches long.
Bits, expansion, $\frac{1}{2}$ to $1\frac{1}{2}$ inch.
Bits, pole, 12 by $\frac{3}{8}$ inch and 16 by $\frac{3}{8}$ inch.
Braces, ratchet, 8-inch sweep.
Buffalo grip, with pulleys, No. 1 size, for wires up to No. 6; No. 2 for wires up to No. 0.
Chain, steel measuring, 100-foot.
Chisels, cold, $\frac{3}{4}$ to 1 inch, tool steel.
Chisels, socket framing, handles for, ring topped, best quality hickory.
Chisels, socket framing, $1\frac{1}{2}$ to 2 inch.
Climbers, 16 and 18 inch, with straps.
Climbers, straps for.
Connectors (splicing clamps), for wires Nos. 9 to 16, iron; for Nos. 8 to 12, copper (for McIntire connections).
Coppers, soldering, with handles, 1, 2, and 4 pound.
Coppers, soldering, handles for, with ring ferrule.
Drill, rock, made of best tool steel, per pound, large and small sizes.
Files, dentist, 5-inch, triangular; 8-inch, round; flat; bastard; half round, 8-inch.
Files, handles for, wood.
Furnace, gasoline, with 5-inch pot and ladle.
Hatchet; 4-inch blade.
Hammers, claw, 18-ounce.
Hammers, machinist, 2-pound.
Handles for hammers and hatchets, best-grade hickory.
Handles with tools.
Hooks, cant, 4-foot, with handle.
Hooks, carrying, 4-foot handle.
Kit, inspector's pocket tool.
Knives, draw, telegraph pattern, 12 and 14 inch blade.
Knives, electrician's.
Lanterns, excavation, ruby globe.
Pick handles, straight-grain hickory.
Pike poles, 12, 16, and 18 foot, 2 inches in diameter, straight live ash or white or yellow pine, to suit locality.
Picks, 7 to 8 pound.
Post-hole augers, 12-inch, 5 feet long.
Post-hole diggers, 7-foot handle.
Pike, guarded or raising, 14-foot.

Pliers, lineman's, 6-inch side cutting, 8-inch side cutting, and 6-inch diagonal.

Pole support, jenny.

Pole support, mule.

Reels, pay-out, with handles and shoulder straps.

Reels, take-up.

Reel jacks, H. I. W. make.

Reel jacks, axles for, steel, 1, 1½, 2, and 2½ inch, per foot.

Rope, pure manila hemp, ¾-inch, in coils of 1,000 feet; ½-inch, in coils of 1,000 feet; ¾-inch, in coils of 500 feet; ¾-inch in coils of 500 feet; 1-inch, in coils of 500 feet.

Rules, carpenter's, 2-foot, brass-tipped, and brass-hinged.

Rules, zig-zag, 4-foot.

Saws, crosscut.

Saws, hack, blades, 12-inch.

Saws, hack, frame 9 to 12 inch, adjustable.

Saws, hand, 26-inch, No. 7, 8-point.

Saws, rip, 26-inch, 5½-point.

Screw-drivers, perfect, 3, 4, 6, and 12 inch.

Shovels, 6 and 8 foot handles, with 18-inch straps.

Shovels, handles for.

Spades, grading, round and square pointed, D handles.

Spades, handles for.

Spoons, 6 and 8 foot handles, 18-inch straps.

Sheaves, double and single, wood or iron, with one or two becketts; or with becket and hook, Ford's patent bushings, sizes 3, 4, 5, and 6.

Tapeline, high-grade cloth, 100-foot and 50-foot, in feet and inches, leather case.

Torches, blow, hot-blast.

Tree trimmers, large size, without saws.

Tree trimmers, large size, with saws.

Tree trimmers, handles for, 18-foot, with ferrule joint.

Vise, jackstrap and, 5½-inch vise, black leather strap.

Wrench, combination lag and nut screw.

Wrench, steel tie, for Nos. 8, 10, and 12 wire.

Wrenches, monkey, 10 and 12 inch.

AERIAL CABLE CONSTRUCTION.

The first step in laying out a telephone system for a post is to procure a large accurately scaled map showing all buildings, present and projective, walks, roadway, contours, and all other objects affecting the location of telephone lines. On this indicate the location of the switchboard and all the instruments to be connected to it. The routes of the various leads of poles and course should now be indicated. These should be determined only after personal inspection of the ground and conference with the post authorities. It is important that the routes as laid down in the first instance should not be changed later as by so doing the material ordered may be rendered unsuitable with resulting expense and delay in procuring new supplies. Avoid changing pole line from one side of the street to the other, trees, or other obstacles that would interfere with the line, sharp curves, and electric-power wires. The aerial construction should be as incon-

spicuous as possible—other things being equal, run in rear of buildings in preference to front. It may be stated in general that cable should be used where five or more pairs are to be carried in one lead. In laying out cable distribution, the future needs of the service should be provided for as far as possible and spare pairs made available.

A typical cable distribution suitable for systems of 50 lines is shown in figure 130. It is of advantage to reduce the number of types of cable used as far as possible. Figure 130 shows a complete system with no open wire lines. When it is necessary to connect aerial wires to cable this should be done through fuses and arresters installed in a can top or cable pole box. A typical method of installing a can top is shown in figure 131, where drop wires are connected to the cable; the tap taken out of the main cable will never be less than ten pair. Thus, from headquarters to point A three terminals are shown, in each of which pairs 1 to 10 are taken out. From A to end of lead two terminals are installed in each of which pairs 11 to 20 are taken out. This provides a multiple distribution by means of which the same pair may be connected to at different points as conditions may require. Pairs should never be dead ended inside the cable. All paper core cables should be connected to a pothead before connecting to cable boxes. Can-top terminals may be furnished with a piece of cable attached in which case all that is necessary is to make the splice to main cable. A typical can-top terminal with cover partly removed and cable attached is shown in figure 132.

Pole lines for aerial cable should be built as specified for open wire lines in the preceding part of this chapter. The setting and guying of poles should be given special attention, and on corners and terminal poles it is of first importance that the poles hold their original positions rigidly if the cable is to remain in a neat and workmanlike manner after erection. After the erection of the pole line has been completed, with all guys, anchors, etc., installed, the messenger wire should be erected. For No. 22 gauge cable, up to and including 50 pairs, five-sixteenths inch diameter of strand is used. For other sizes three-eighths inch strand will be required. The same size of strand that is used for carrying the cable should also be used for guys. The properties of the various sizes of strand commonly used are given in the following table:

Strand of 7 wires, B. W. G., No.—	Breaking strain.	Diameter of strand.	Lay.	Elongation of each wire in 10 inches.		Weight per 100 feet.
				Maximum.	Average.	
8	<i>Pounds.</i> 11,000	<i>Inches.</i> $\frac{1}{8}$	<i>Inches.</i> 4 $\frac{1}{2}$	<i>Per cent.</i> 13	<i>Per cent.</i> 11	<i>Pounds.</i> 52
9	9,000	$\frac{7}{16}$	4 $\frac{1}{4}$	13	11	42
11	6,800	$\frac{1}{2}$	4	13	11	30
12	4,860	$\frac{5}{8}$	3 $\frac{1}{2}$	12	9	22
14	3,050	$\frac{3}{4}$	3	12	9	13
16	2,000	$\frac{7}{8}$	3	10	9	8

AERIAL CABLE DISTRIBUTION

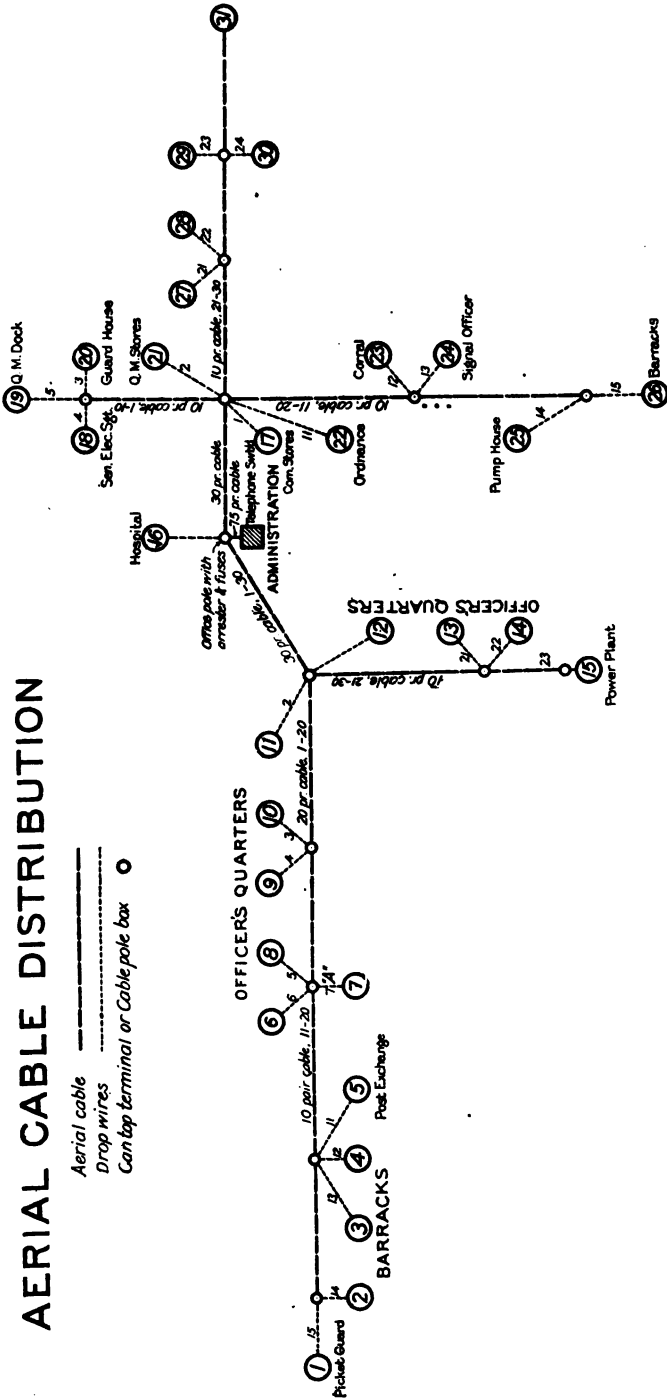

FIG. 130.

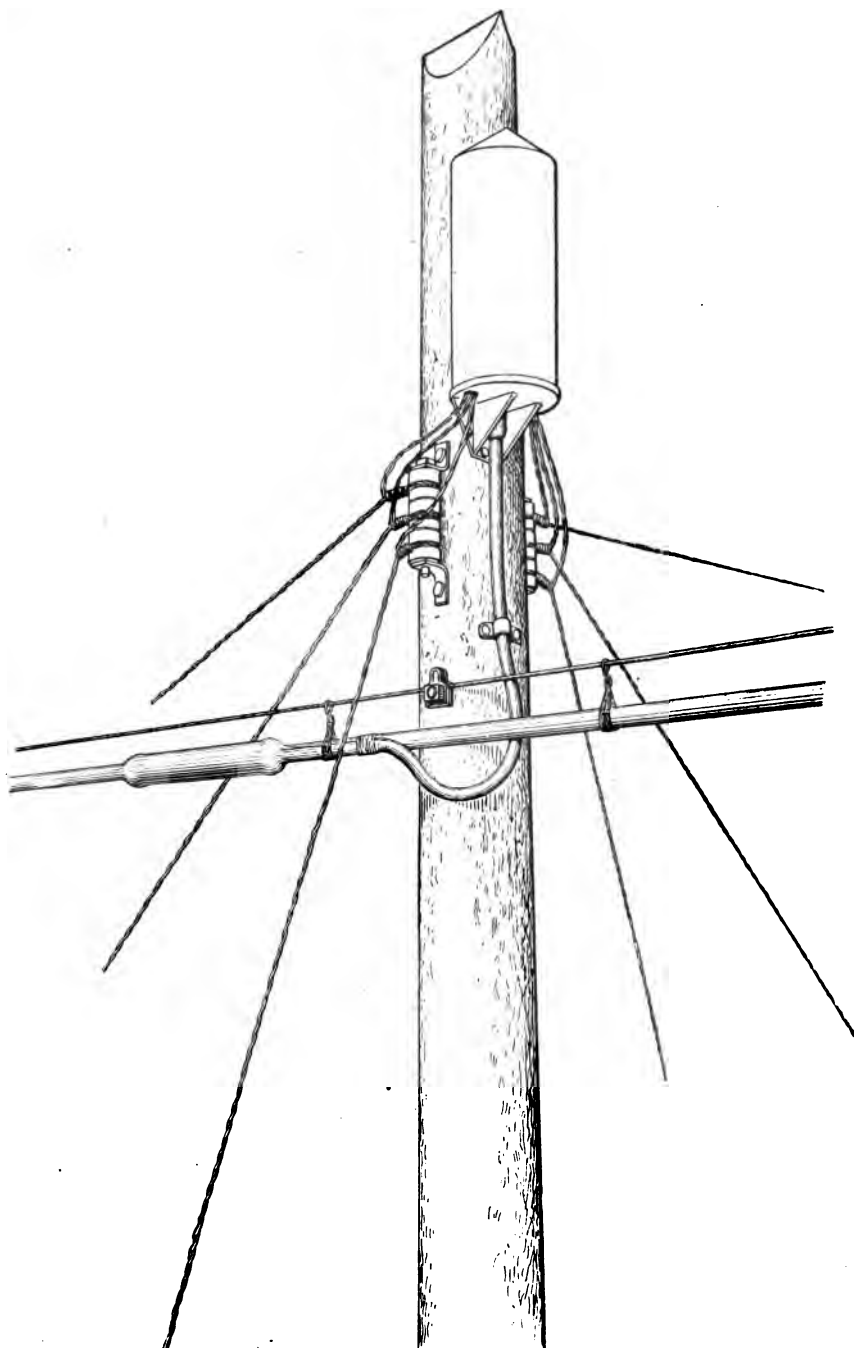

FIG. 131.—Method of installing can top terminal.

An approved method of dead ending messenger wire is shown in figure 133.

It is desirable that the messenger run from anchor stub to anchor stub without splice, running past last pole without change of level

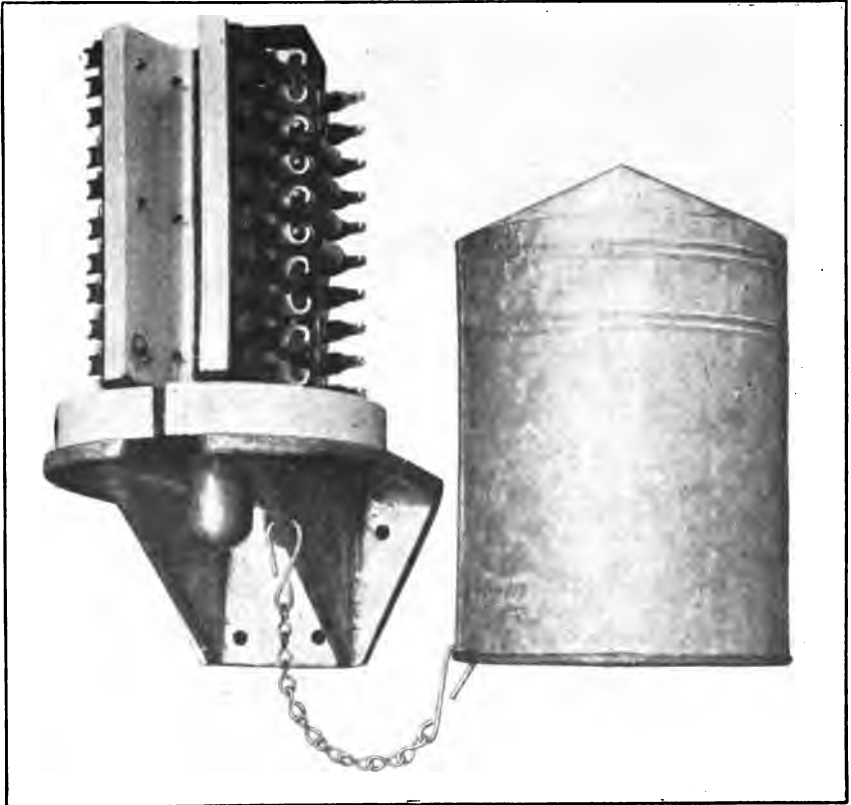

FIG. 132.—Can top terminal.

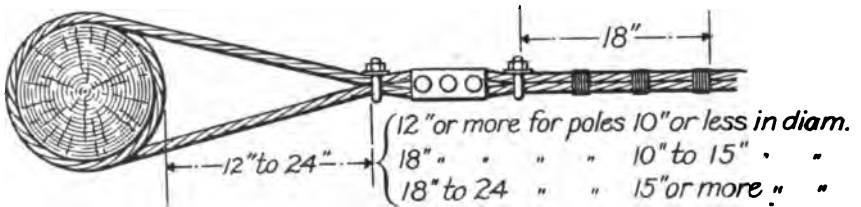

FIG. 133.—Method of dead ending strand.

to a guy stub. The terminal pole and stub are then guyed, as shown in figure 134.

Whenever possible the anchor for the stub should be placed at a distance from the stub equal to the distance from the guy to the ground level. This will give the anchor guys an angle of about 45

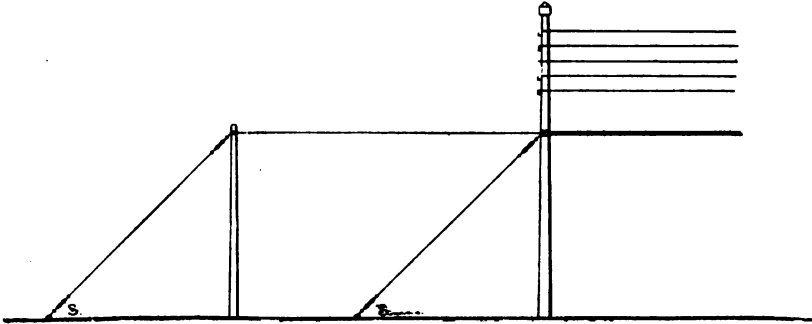

FIG. 134.—Method terminating messenger strand.

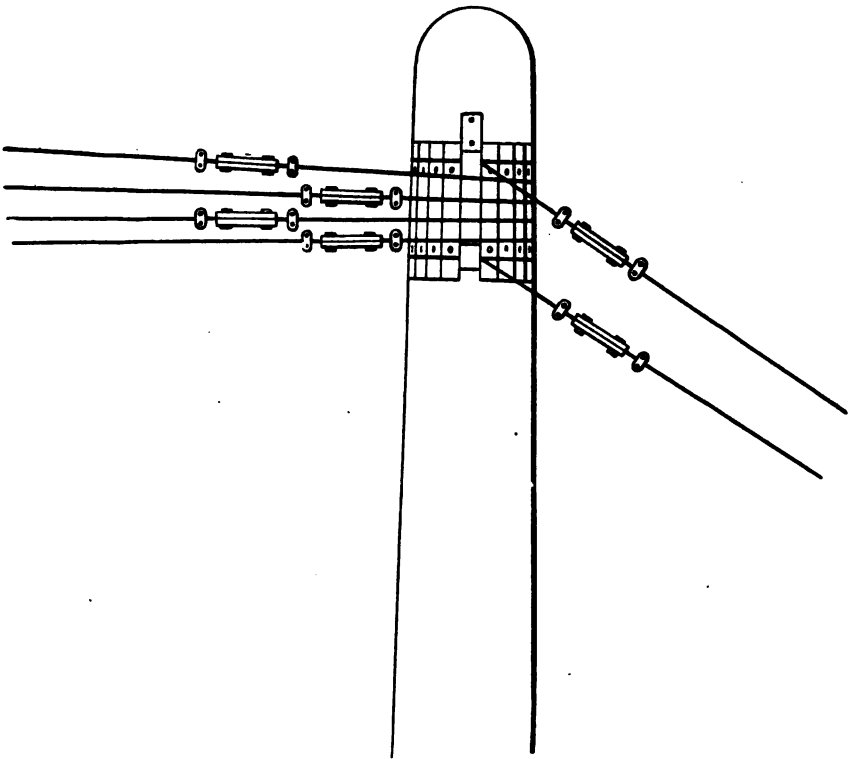

FIG. 135.—Guy shims and hooks.

degrees. On all poles or stubs where steel strand or messenger dead ends or extra heavy guys are installed, guy shims and hooks should be used as shown in figure 135. These shims are to form a continua-

tion around the pole from edge to edge. Thimbles should be used in the eyes of all anchors.

Messenger should be pulled from anchor stub to anchor stub without break if possible. Splicing of messenger should be avoided, but if necessary may be done as follows: Two ends of the messenger should

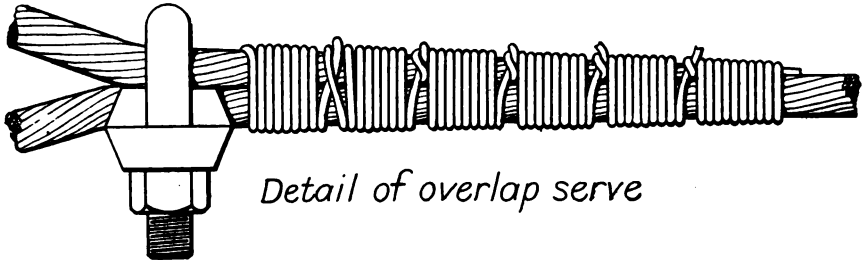

FIG. 136a.—Splicing messenger wire.

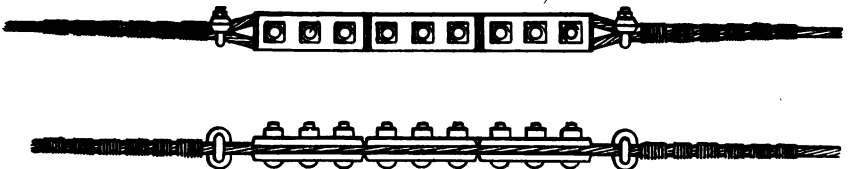

FIG. 136b.—Splicing messenger wire.

be lapped about 6 feet. Three 3-bolt clamps should be put on in the center lapping sections, spacing them so that they touch end to end. At each end of the outside of the three bolts one Crosby clip should be placed $1\frac{1}{2}$ inches from the three bolts with the yoke over the short end

of the messenger and the bearing plate on the main messenger. The end should be served up with overlapping sections of serving as shown. The completed splice is shown in figure 136b.

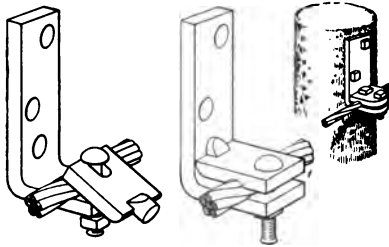

FIG. 137.—Method of attaching messenger supports.

Various methods of attaching the messenger to poles are used. Messenger supports attached with two lag bolts placed as shown in

figure 137 are most commonly used.

A messenger support attached by a through bolt may also be used as shown in figure 138. In ordering supports of either pattern, the size of the strand with which they are to be used should be given. Bolts for attaching are not furnished as a part of the support and should be ordered separately. The messenger supports should be

installed before the strand is run out. To erect strand, place the reel on an axle supported by two jacks, if available, and run off the required length along the line as near the poles as possible. This is then carried up the pole by the linemen, the hangers being already in place. One end is then dead ended, as shown in figure 133. At the other end a pair of 6-inch triple blocks should be hung on the guy stub terminating the pole line and slack taken out of the messenger and carried around the pole loosely and fastened with a clamp for safety. Next, a 10-inch snatch block is hung just below the guy shims on the side of the pole parallel with the street. It should be secured to the pole with the equivalent of four turns of inch rope. A piece of three-eighth inch strand measuring 100 feet or more should be attached to the messenger by means of Crosby clips or three-bolt guy clamps in a permanent manner, approximately 15 feet from the stub. The piece of strand attached to the messenger should now be carried through the snatch block to the butt of the next pole, a tree or other sufficiently firm object. A pair of 10-inch triple-pole hoisting blocks should be made fast to this pole or other object and lashed with two turns of inch rope or its equivalent. These blocks should be attached to the strand leading over the snatch block with the blocks spread at least 30 feet. A pair of luff blocks should be attached to the fall of the main blocks by a stopper hitch, allowing the main fall to be snubbed around the nearest solid support. The slack should now be pulled up by the fall of the luff blocks, using for this purpose a horse or force of ground men. The arrangement of block and tackle described is shown in figure 139.

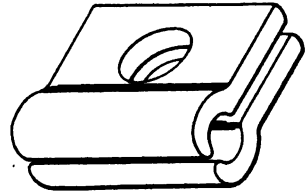

FIG. 133.—Messenger support.

When the desired tension has been secured, the main fall should be permanently snubbed and the messenger made fast. This is done by passing the end twice around the pole, the free end hooked to one end of a pair of 6-inch triple blocks. The other end of these blocks should be secured to the main messenger. The fall of these blocks should be carried through a second and smaller snatch block to the ground, where it may be handled with other luffs to take out the slack in the messenger.

When this is done, the messenger is secured by Crosby clip and 3-bolt guy clamp, as shown in figure 133. The tension of the main blocks should be eased off gradually and with caution until the dead end of the messenger has taken up the full strain. This having been completed, the messenger supports should be tightened up on each pole.

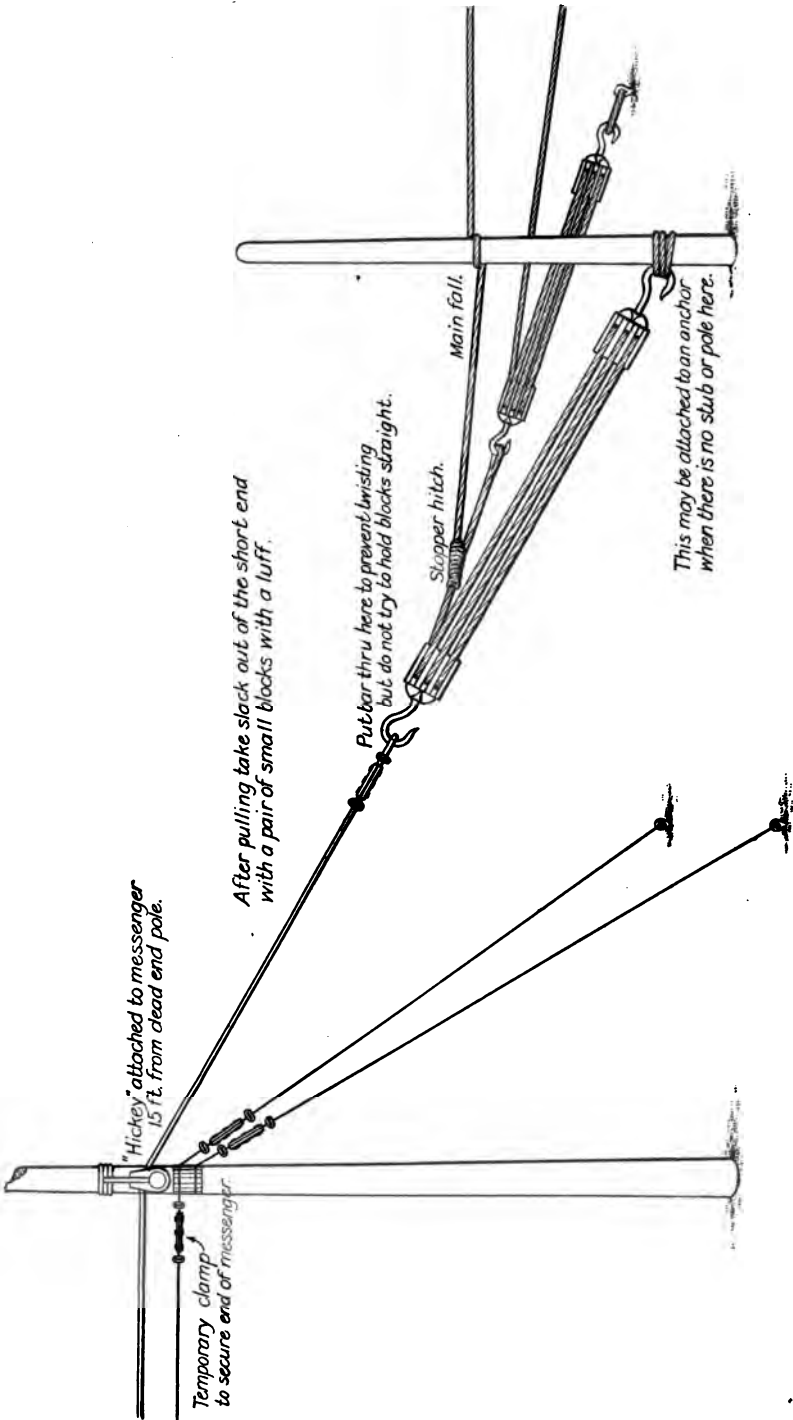

FIG. 139.—Method of arranging blocks.

The method of putting up messenger just described is of general application and will be found suitable for the heaviest strand installed. In most cases for small systems the method may be somewhat simplified and the details described should be modified accordingly.

The messenger should never turn double corners or change from one side of the street to the other by being pulled around the corner. On double corners messenger and cable should make the square turn, as shown in figure 140. On changing sides of the street the messenger should go straight past the last pole to a stub or anchor, beginning again on the opposite side of the street in the same manner, both corner poles being side guyed. This is shown in figure 140.

When the cable is in place on the messenger the sag in inches should not exceed the limits of the following table:

Temperature.	100-foot span.	120-foot span.	140-foot span.	160-foot span.	180-foot span.	200-foot span.
°F.						
-30	12	17½	23½	30½	39	48
0	12½	17½	24	31½	40	49½
+30	12½	18½	25½	33½	42½	52½
60	13½	20	27½	36	45½	56½
90	15½	22	30	39½	50½	63½
120	18	25½	34½	42½	55	67½

When pulling the strand taut allowance should be made for the weight of the cable, which will increase the sag, and the strand should be made correspondingly taut. It will hardly be possible to place the strand under too great a tension. As the strain is applied careful watch should be kept for loosening guys or anchors, buckling of poles, etc. The blocks should be attached to the messenger wire by means of steel comealongs rather than Buffalo grips. They may be attached to the pole or anchorage by the use of a sling of messenger strand or manila rope.

GUYS.

If a single messenger wire is used on a universal hanger the pole guys should be placed above and as close to the messenger as possible. The guys should be wrapped twice about the pole or guy stub, and should be held with guy clamps. With five-sixteenths-inch or three-eighths-inch strand one three-bolt clamp only will be needed.

Where several guys are placed on one pole they should be assembled as closely as possible, but should not overlap or bind each other. When head guys, storm guys, strand or other guys are fastened to the butt of the pole they should be as close to the ground as possible, but usually not nearer than 8 feet. Guy stubs should not be left with any side strain whatever. This can be prevented in two ways, by side-guying the stub itself or by bringing the anchor rods, stub, and point of strain in line.

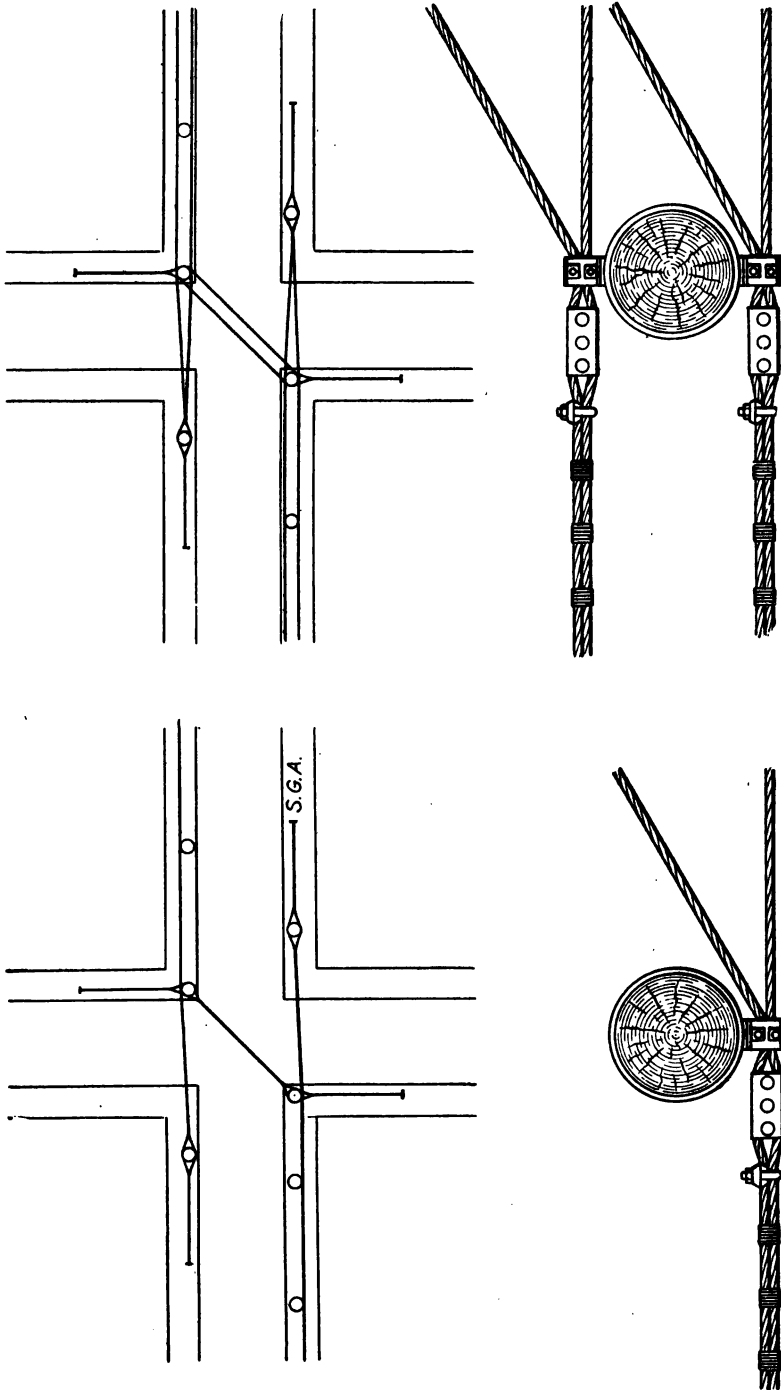

FIG. 140.—Method of changing direction of messenger strand.

Cable messengers should be carried at the lowest level permitted by existing conditions, such as other wires, cables, roadways, etc. The height of the main-cable lead should be adjusted, if possible, to meet the requirements of the branch or cross lead. If the level of the cable messenger is to be changed, it should not be dropped abruptly, but should be graded carefully to meet the requirements.

In serving dead ends of messenger sufficient length should be left in the messenger or guy to pass twice around the pole, to permit of the proper distance between the end of the clamp and pole, and to allow a standard length of 18 inches from the clamp to the free end of the strand. This free end should be carefully tightened and served to main messenger with wrapping of No. 14 iron wire. Where several messengers, or guys dead end on the same pole the ends and serving should be lined up.

If after the slack has been pulled out of a messenger it appears that the grade might have been better, it should be considered of sufficient importance to raise or lower the support or supports necessary to bring this about. If the conditions are favorable, cable supports may be placed on the poles by tape-line measure from the ground to determine the height. If, however, the ground is uneven or the conditions are otherwise unfavorable small pieces of lath or equivalent may be tacked on the pole and raised and lowered until a satisfactory grade is secured, the messenger supports then being placed at these points. The preliminary pull on the messenger will determine the correctness of the spacing of the supports.

For post telephone systems, paper-insulated, lead-covered cable will largely be used. For interior posts the conductor will be No. 22 B. & S. gauge copper. For coast artillery posts No. 19 gauge is standard. The properties of the usual sizes of both gauges of cable are given in the following table for types 401 to 419, inclusive:

Type No.	Designation.	Conductor, B. & S. gauge.	Thickness of lead sheath.	Approximate outside diameter.	Weight per statute mile.	Weight, 1,000 feet of cable and reel.
			Inches.	Inches.	Pounds.	Pounds.
401...	10-pair aerial.....	19	☆	0.722	5,370	1,186
402...	15-pair aerial.....	19	☆	.797	6,193	1,368
403...	20-pair aerial.....	19	☆	.872	7,054	1,558
404...	25-pair aerial.....	19	☆	.922	7,693	1,700
405...	30-pair aerial.....	19	☆	.982	8,416	1,860
406...	40-pair aerial.....	19	☆	1.113	11,083	2,448
407...	50-pair aerial.....	19	☆	1.208	12,445	2,750
408...	75-pair aerial.....	19	☆	1.443	15,829	3,497
409...	100-pair aerial.....	19	☆	1.638	18,860	3,967
411...	10-pair aerial.....	22	☆	.607	4,229	935
412...	15-pair aerial.....	22	☆	.682	4,937	1,093
413...	20-pair aerial.....	22	☆	.737	5,549	1,228
414...	25-pair aerial.....	22	☆	.787	6,088	1,345
415...	30-pair aerial.....	22	☆	.827	6,520	1,441
416...	40-pair aerial.....	22	☆	.943	8,664	1,914
417...	50-pair aerial.....	22	☆	1.023	9,646	2,131
418...	75-pair aerial.....	22	☆	1.193	11,890	2,627
419...	100-pair aerial.....	22	☆	1.353	14,050	3,106

In using the data given above, it should be borne in mind that the values will vary slightly with the different manufacturers and orders. This cable is usually furnished on reels in lengths of 1,000 feet, but other lengths are furnished when called for on order. The standard reels are 33 inches in length and have a diameter of from 56 to 72 inches.

In addition to the paper-insulated cables noted above, single-pair rubber-insulated cable, type 213, is also employed. This has the following properties: Conductor, 7 strands, No. 21 B. & S. gauge; thickness of lead sheath, one-eighth inch; outside diameter over lead sheath, about five-eighths inch. Furnished on reels in one-half mile length, weighing approximately 3,000 pounds.

CABLE HANDLING.

Great care should be taken in handling cable in carrying it to the work and in delivery from railroad yards to storehouses. Cable should never be dropped from a platform or wagon, and the reel should never be laid on the side. Reels will usually be marked on the end with a heavy arrow showing the direction in which they should be rolled in transportation. The loading or unloading of reels should only be done under the supervision of a responsible party who understands the handling of cable.

HANGING CABLE.

The messenger having been prepared for the cable, the cable rollers should be placed in position on the messenger and spaced from 15 to 20 feet apart. The cable should be placed approximately one span from the beginning of the run and suspended on cable-reel jacks. A temporary leading-up guy should be placed in position equipped with rollers. A drag line for pulling the cable should be brought through the rollers from the distant end of the run and attached to the cable by suitable means, such as a cable grip. The cable may then be pulled through the rollers by means of a team of horses, winch, or a force of ground men. After the cable has been run out the proper length one end should be made fast, a pair of heavy blocks with luff attached to the other end, and the slack pulled out before snubbing. In drawing cable, great care should be taken to avoid crimping the sheath or choking the cable. Snubbing with pieces of rope put on with a half hitch is positively forbidden. The cable should not be pulled around corners unless the cable terminates within one span of the corner. If the run is greater than one span, the cable should be cut and spliced.

LAPPING FOR SPLICING.

Three feet of lapping section is all that is necessary. This does not mean that 5 or 8 feet should be allowed. Whenever necessary to cut a cable, as at the end of a run or otherwise, exposed wires should be driven within the sheath by a pin or bolt and the sheath closed over same and sealed with solder. This is to be considered an absolute rule—to seal all cable ends in this manner immediately after cutting.

ATTACHING CABLE TO MESSENGER.

The cable hangers should be spaced 15 to 18 inches apart, using spacing stick for this purpose. When the cable hangers are attached care should be taken to dress the cable properly, carefully removing all kinks, curves, etc., as the cable is placed in position.

PROTECTION OF CABLE.

Where cable is liable to come into contact with wires, tree limbs, guys, or other objects which will injure the lead sheath, a guard of wooden strips should be put on and lashed with marlin. Pump log split lengthwise is sometimes used for this purpose.

CABLE-BOX GROUND.

Arrester ground for cable terminal poles should be carried straight down the pole without any curves, sharp turns, or coils, and as far as possible, without splicing. This ground should consist of a copper wire of suitable size attached to a ground plate or ground rod buried permanently in moist earth.

SPLICING LEAD-COVERED, PAPER-INSULATED CABLES.

These instructions cover improved methods, with the materials required, for splicing lead-covered, paper-insulated cables. They apply equally to aerial or underground work.

MATERIAL REQUIRED.

The following material will be required:

Paper or cotton sleeves, paraffin, strips of muslin, or equivalent, lead sleeving, wiping solder, stearin, gummed paper.

Before being used paper sleeves should be boiled out in paraffin.

For wrapping the core after splicing and for binding the ends of a splice strips of muslin, or soft twine, should be used.

The dimensions and weight of sleeves used in splicing cables of various sizes, and amount of solder per joint, are given in the following table. Where the cables to be spliced together are not of the same size the proper size for the larger of the cables shall be used.

Lead sleeves for straight splices.

Inside Diameter.	Size of sleeve.		Size of cable used with—		Pounds of solder per joint.
	Thickness of lead.	Weight per foot.	19 gauge.	22 gauge.	
<i>Inches.</i>	<i>Inch.</i>	<i>Pounds.</i>	<i>Pairs.</i>	<i>Pairs.</i>	
$\frac{1}{2}$	0.11	1			
$\frac{3}{4}$.10	1 $\frac{1}{2}$			
1	.11	2	10	10 and 20	0.9
1 $\frac{1}{2}$.12	2 $\frac{1}{2}$	20	25	1.2
1 $\frac{3}{4}$.14	3 $\frac{1}{2}$	25	30	1.5
1 $\frac{1}{2}$.13	4			2.0
2	.15	4 $\frac{1}{2}$	50	50	2.5
2 $\frac{1}{2}$.125	4 $\frac{3}{4}$	100	100	3.7

Sleeving is of pure lead and is purchased in 10-foot lengths. In ordering state number of feet required and inside diameter—the sleeves to be cut on the work as needed. The length of sleeves varies from 16 to 24 inches—usually is 18 inches.

Splices should in every case be finished and wiped the day they are begun. In wet surroundings or very damp weather work should be continuous until finished. In such cases the splice should be “boiled out” with paraffin at intervals—say, after each 50 pairs have been connected.

Whenever it is necessary to leave a cable end, it should be thoroughly dried and sealed with solder, as much care being taken as if the seal were to be permanent.

A record should be kept of all splices, with the name of the splicer and any item of interest. Each splicer should be held personally responsible for any faults which may develop in his work due to defective workmanship.



FIG. 141.

The operations in making a straight splice are as follows:

Remove the sheath from the ends of the cables to be spliced for a distance equal to the length of the sleeve to be used. Now wind the core tightly with strips of muslin or soft twine at the end and close to the sheath. This is done to prevent the wires from being cut on the edge of the sheath. To remove, cut the sheath lengthwise from the end back to the desired point, cutting through the sheath, but being very careful not to injure the insulation. This is shown in figure 141.

Next, make a score entirely around the cable at the end of the lengthwise cut, as in figure 142. Do not cut quite through the sheath.

The lead may now be removed with a pair of pliers. The exposed conductors shall now be thoroughly "boiled out" by pouring hot paraffin over them until all traces of moisture are removed. The binding must be saturated with paraffin as well as the core. Enough paraffin remains in the core to form a seal, which protects the cable against moisture while the splice is being made. The temperature of the paraffin shall be above that of boiling water, but must not be high enough to char paper insulation.

In drying or "boiling out" a splice with paraffin, always work away from the cable sheath toward the end of the conductors or middle of the splice, in order to prevent any moisture being driven under the sheath.

The ends of the cable sheaths and of the lead sleeve shall be scraped bright for 3 or 4 inches and rubbed with tallow, or stearin to keep



FIG. 142.

them clean during the subsequent work on the splice. The tallow also acts as a flux in making the wiped joints.

The lead sleeve shall next be slipped over the most convenient end of the cable.

The two cable ends shall be placed and firmly secured in the same straight line, with the distance between the ends of the sheaths about 3 inches less than the length of the lead sleeve.

After the cables are in position the conductors shall be bent at the sheath out of the way and shall then be spliced in the following manner:

Starting at the center or the lower back side of the cables, a pair of wires from each cable is loosely brought together with a partial twist (*a*, fig. 143), thus marking by the bend in the pairs the point at which the joint is to be made. Slip on a paper sleeve over each wire of one pair and push the sleeves back far enough to allow room for making the joint.

The wires are now to be connected by a splicer's ordinary twist joint (*b*, fig. 143). The like wires from the two pairs to be spliced shall be brought together at the point marked by the bend and given two or three twists (*c*, fig. 143). Remove the insulation of both wires beyond the twist, being careful not to nick or scrape the conductors. The wires are now to be bent as shown and twisted together as if turning a crank. The ends shall be cut off so as to leave the twist of bare wire not less than 1 inch in length. The twist shall be bent down along the insulated wire and the paper sleeve slipped over the joint (*d*, fig. 143). The

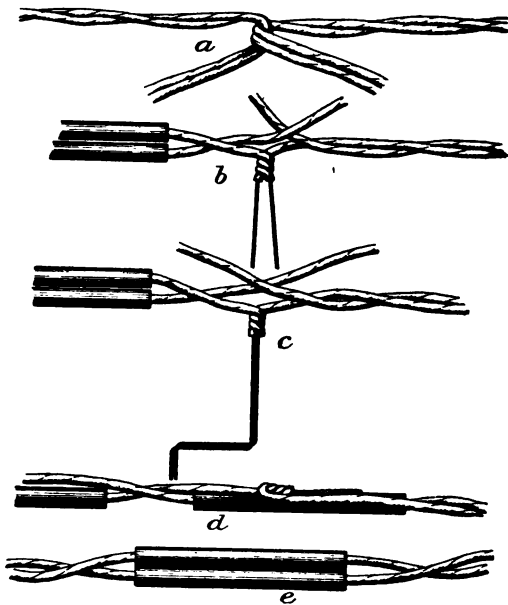

FIG. 143.

completed joint, with the sleeves in place, is shown in *e*, figure 143.

In splicing, care shall be taken to splice the center and lower pairs first, forming the outer pairs about the center pairs so that the finished splice may have a uniform shape.

The joints shall be distributed along the whole length of the splice in order to keep the splice uniform in size and shape.

The connected splice shall be again "boiled out" with hot paraffin

until all traces of moisture have been removed. (See fig. 144.) In applying this paraffin, work from the ends of the splice toward the middle.

The splice shall then be wrapped with strips of muslin, or equivalent, and compressed until the lead sleeve will slip over the splice. (Fig. 145.) Care must be taken not to compress the splice too tightly or the wires may be forced through the insulation and crosses result.

The splice shall be dried out with hot paraffin after the wrapping of the splice is complete. The drying out shall be continued until bubbles cease to appear.

The lead sleeve shall be slipped into place before the splice has had time to cool, taking care, however, to see that the sleeve is perfectly dry.

The ends of the sleeve, which should overlap the cable sheath at each end by about $1\frac{1}{2}$ inches, shall be beaten down to conform to the cable sheath and a wiped joint carefully made at each end. In making the wiped joints strips of gummed paper may be used to limit the



FIG. 144.



FIG. 145.



FIG. 146.

joints. A joint in process of being wiped and one completed are shown in figures 146 and 147.

Wiped joints should be carefully inspected, using a mirror when necessary to detect any imperfections in the seal.

3-WAY OR "Y" SPLICES.

The method of making a 3-way or Y splice is the same as for a straight splice, except in the following particulars:

There are two general classes of Y splices—

1. Where the cables all end at the splice.
2. Where a branch cable is to be spliced into a continuous cable.

In the first case the method is generally similar to a straight splice. The sheaths of all three cables are removed for a length equal to the length of the lead sleeve. The two cables forming the main cable are secured in a straight line, with the distance between the ends of the sheaths about 3 inches less than the length of the sleeve. The branch cable shall be lashed beside one of the main cables, with the end of its sheath opposite the end of the sheath of the main cable.

The joint shall be made by twisting together like wires of pairs



FIG. 147.

from each of the three cables, taking care to include two or three twists of the insulation in the joint in the manner described for straight splices.

The lead sleeve in this case may be a whole sleeve.

It should be slipped on and pushed back on that portion of the main cable away from the branch.

In the second case a split lead sleeve must be used.

The sheath of the main cable shall be removed for a length of about 3 inches less than the length of the sleeve. The sheath shall be removed from the end of the branch cable for an equal distance.

The branch cable shall be lashed to the main cable with the end of the sheath opposite the end of the sheath of the cable.

A pair of conductors in the main cable is cut. To one end of each conductor shall be spliced a short piece of bare wire of the same size as the cable conductors. This wire should be twisted into the insulation two or three times in order to prevent its pulling back on the conductors. The second end of the main conductor, the free end of the bare wire, and a like conductor of a pair in the branch cable shall be twisted together, in the manner already described, and covered with a paper sleeve which shall be long enough to cover both ends of the bare wire.

If there is slack enough in the main cable, the joint may be made without splicing in the bare wires.

In putting on a split lead sleeve the seam must be carefully soldered, then the ends beaten down to conform to the sheaths of the cables and soldered with wiped joints in each end. Care should be taken to retouch the ends of the seam after the wiping is complete, in order to make sure that the seam has not been opened while the wiping was in progress.

A grooved wooden block should be placed in the fork of each Y splice in order to keep the cables apart. This block is kept in place, and the cables at the same time protected from the possibility of too great a separation by means of a wrapping of wire soldered to the cable sheaths.

METHOD OF MAKING A POT HEAD.

This description covers the method of making a pot head or flexible cable terminal for terminating the conductors of a lead-incased, dry-core cable in rubber-covered conductors, and at the same time effectually sealing the lead-incased cable against air and moisture.

The wires which are to be spliced to the lead cable should be insulated with rubber or equivalent. The rubber-covered wires may be loose or in the form of a taped cable.

DIRECTIONS FOR SETTING UP THE POT HEAD.

No paraffin shall be used in "boiling out" cable ends and sleeves for pot heads. Make the splice between rubber and paper insulated wires as described for splicing.

Close to the end of the lead cable sheath the wires should be tightly wound with a number of layers of twine or wicking in such a manner as to prevent the compound from entering the cable.

The entire splice should be opened up as much as possible in order that the sealing compound may flow readily about every wire.

The lead sleeve should be drawn over the splice, allowing it to project over the lead cable sheath $1\frac{1}{2}$ inches, and then connected to the lead cable sheath by means of a "wiped" joint.

The lead cable sheath with sleeve attached should now be fastened in an upright position, the sleeve warmed until it becomes barely possible to touch it with the hand, and the sealing compound, heated to as high a temperature as is possible without burning the insulation from the wires, slowly and cautiously poured in through the tube, using a funnel to assist in the operation. The compound should fill the sleeve to within one-half inch of the top. If the compound on cooling should settle, more compound should be poured in at the top of the sleeve.

After the splice has become thoroughly cold the open end of the lead sleeve should be carefully dressed into contact with the taped leather which surrounds the rubber-covered wires or cable.

No pot head should be mounted in other than an upright position, if exposed to the weather. When it is necessary in inside construc-

tion to place the pot head in a horizontal position the open end of the lead sheath should be wrapped with tape to prevent the com-

compound from running out, and care should be taken to locate the terminal where it will not be exposed to excessive heat.

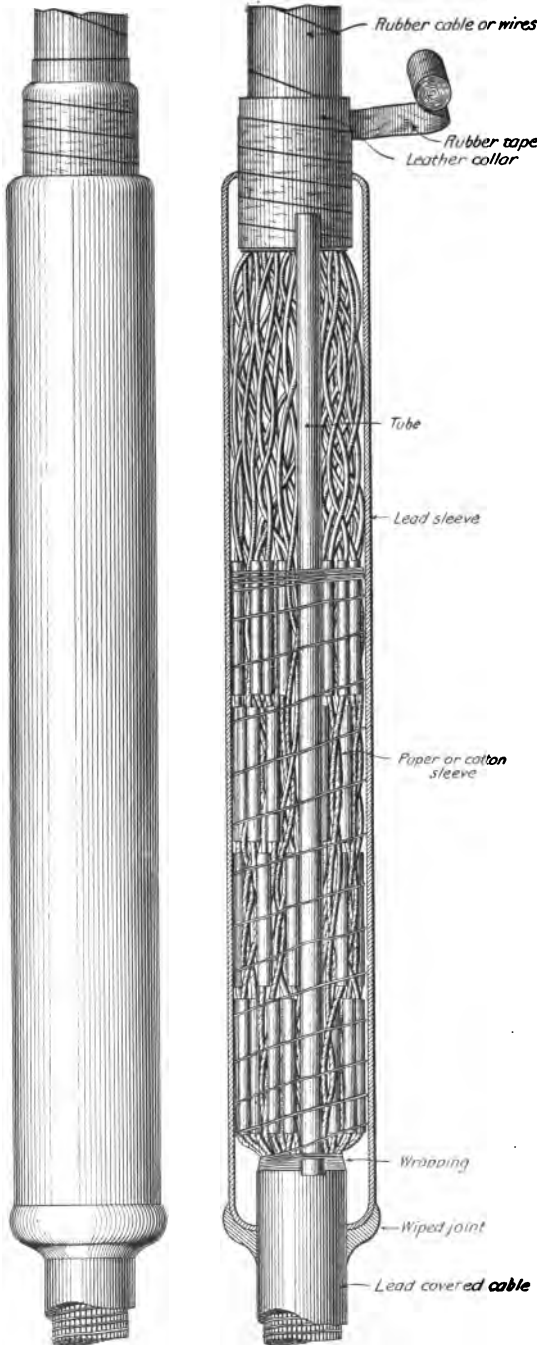

SUGGESTIONS IN REGARD TO SPLICES.

In branching a small lead-covered cable from a flexible splice it is considered advantageous to run it out at the base of the lead sleeve, making a double-wiped joint, rather than to run it out parallel with the rubber-covered wires or cable.

Should occasion arise when it becomes imperative to shorten the length of the lead sleeve, a sleeve of a greater diameter than is ordinarily recommended should be selected and the space occupied by the joints in the wires contracted, keeping the space between the last wire joint on the rubber-covered wire end and the leather wrapping the same as it would be in a regular splice, this being the space where the efficiency of the seal is maintained.

FIG. 148.

A completed splice is shown in cross section in figure 148.

UNDERGROUND CABLE.

It is desirable to place cables underground wherever possible. This avoids the pole lines and the necessity for running pole lines about the post in conspicuous locations, secures the cable from many sources of injury common to aerial lines, and makes the system reliable in operation and easy to maintain. Underground construction will, in general, be more expensive than aerial, and this consideration will usually determine the form of construction to be followed. The first step is to decide on the general layout of the system. The procedure should, in general, be the same as outlined for the aerial plant. In selecting the routes, attention should be given to the contour of the post; location of material obstacles to cable runs; buildings, existing and projected, and probable extensions of the system in the future. The runs between manholes should be without curves or bends. A diagram of pair distribution similar to figure 149 should be made, after which the lengths of the various sizes of cable can be determined.

Two general methods of placing cable underground may be followed—trenching and conduit. The first costs less to install and does not require skilled labor, but has the disadvantage that the cable is not accessible for repair and once installed can not easily be removed. Trenched cable is also more liable to mechanical injury after laying. It may be stated as general that trenching will be confined to lateral runs of type 213 cable. All paper-insulated cable, as far as practicable, will be placed in conduit.

TRENCHING CABLE.

The route being staked out, the trench should be excavated of sufficient width and not less than 18 inches in depth if practicable. Care should be taken that the bottom of the trench and the first earth used for filling in are entirely free from stones, sticks, or other material which will injure the cable sheath under pressure. The cable may be pulled into the completed trench from the reel, held on cable jacks. In pulling into trench, avoid drawing cable over sharp projections which would score the sheath. The same precautions should be employed in sealing ends, splicing, and potheading as for aerial cable. After the cable is laid and spliced it should be covered with rough boards about 1 by 6 inches of such timber as can be easily obtained locally. The trench may now be filled. The route of trench with splices located should be recorded on scale map.

CONDUIT.

In laying out a conduit system, provision should be made for placing all paper-insulated cable in conduit if practicable. In all conduit construction, the following general construction will apply.

DIAGRAM OF UNDERGROUND CABLE DISTRIBUTION

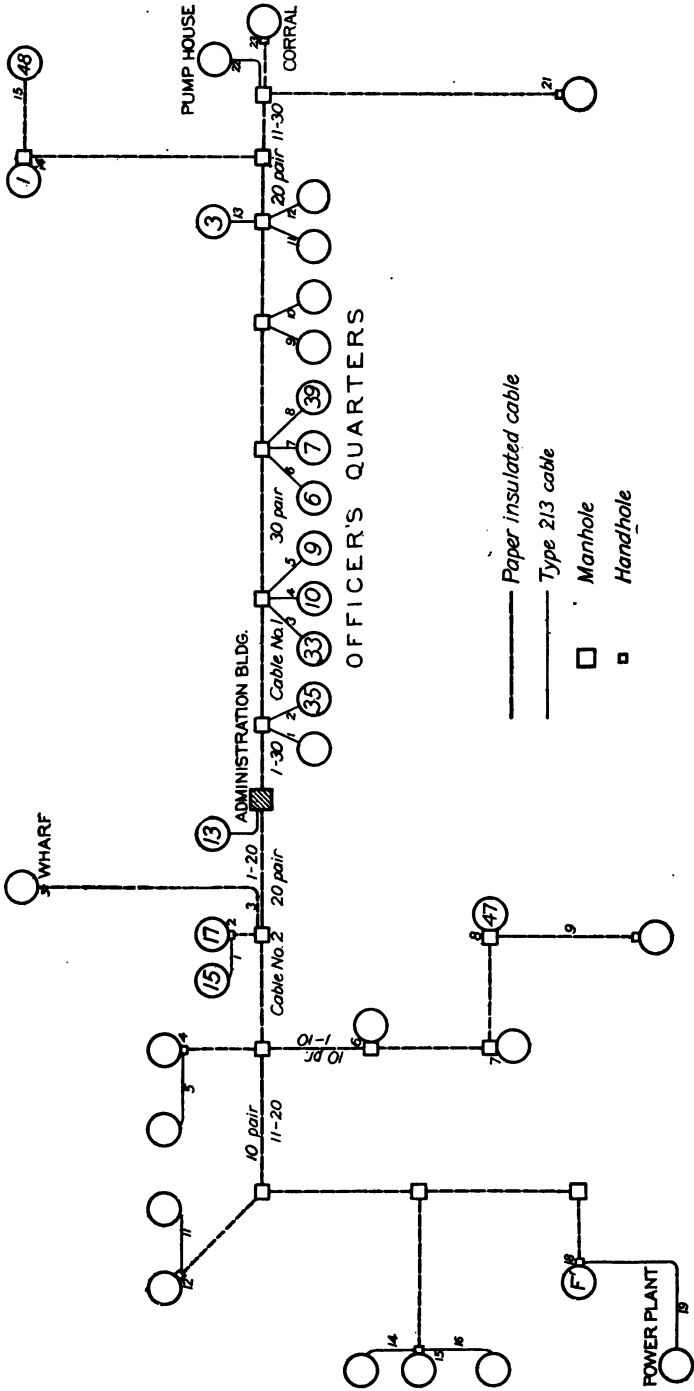

FIG. 149.

The top of the conduit line should never be less than 18 inches below the surface. In many places this depth will be exceeded in order to maintain the grade of the duct line. The distance between manholes should be as great as local conditions and the length of the cable that can be pulled into a duct will permit. Where fiber or pump log conduit are used this distance should not exceed 400 feet; for clay conduit 350 is considered the maximum. As cable is usually furnished in lengths of 1,000 feet, the spacing should be such as to cut this length without waste or accumulation of short pieces.

In general, it is desirable to run conduit or trench in rear of buildings and quarters to avoid cutting up turf or lawns unnecessarily. The location of the main line should be such as to afford the most economical and convenient distribution to stations. All excavations, especially on roadways, should be guarded outside of working hours by suitable barricade and lanterns to prevent injury to traffic. Avoid opening long stretches of trench in which the cable or conduit can not be laid without delay. In many cases a plow may be used to good advantage to remove the top layer of earth. Conduit will not be laid in concrete unless four or more ducts are used. Conduit should be laid in straight line and at same grade between manholes. All curves should be made at a manhole or hand-hole. The bottom of the trench should be smooth and firmly tamped before laying conduit. All work in connection with conduit construction should be done under the supervision of a thoroughly competent foreman.

The types of conduit used are bituminized fiber, pump log, and vitrified clay. For most of the Signal Corps work, the fiber conduit will be used on account of ease of installation and less first cost of material.

The vitrified clay conduit is more permanent in character and is suitable for conditions requiring unusual strength and rigidity. The plans shown herein are for fiber conduit in all cases. Where this type is not available use may be made of either of the other types.

The standard fiber conduit is made in 7-foot lengths, 3-inch inside diameter and three-eighths inch wall, weighing 2 pounds per foot. The lengths of conduit are made with male and female slip joints as shown in figure 150. When laying the conduit, the end of each section should be dipped into a waterproofing liquid before jointing. Care should be taken to close the joint completely and to avoid placing stones or other material next the conduit in filling. The work of laying may be begun at a manhole or at any part of the trench. Where the conduit work is discontinued temporarily for any cause, the exposed duct ends should be plugged and covered with a tarpaulin until work is resumed. Where short lengths are required the standard pieces may be cut with a handsaw, using water to prevent sticking of the saw. Care should be used in handling the con-

duit to avoid breaking the ends. The fiber conduit is made up in the usual elbows, tees, and bends.

MANHOLES.

To provide for access to conduit for pulling, splicing, inspection, and repair of cables, manholes are placed as needed. The usual form is shown in figure 151. The dimensions of this figure may be varied to suit special conditions. A large number of formulas are in use for mixing concrete. The proportions for stone, sand, and cement vary with the size and character of the stone, the quality of the cement, and the purpose for which the concrete is to be used. A good general formula is 1 part cement, 3 parts sand, and 6 parts stone. For gravel, 1-2½-5 will be better. In making estimates it should be borne in mind that the volumes of cement, gravel, sand, and stone taken separately will be greater than the volume of the

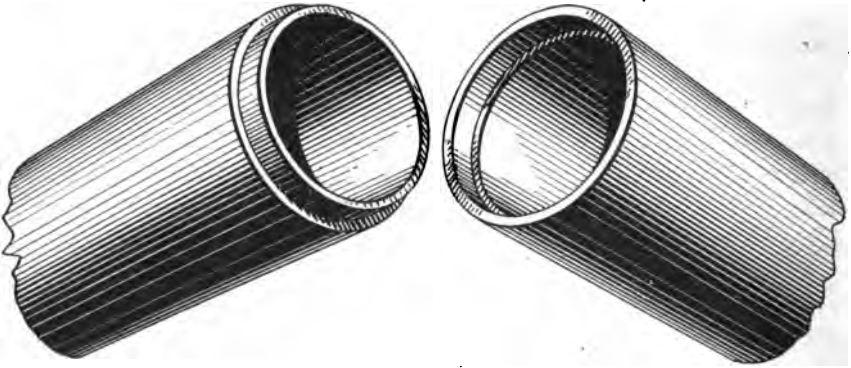
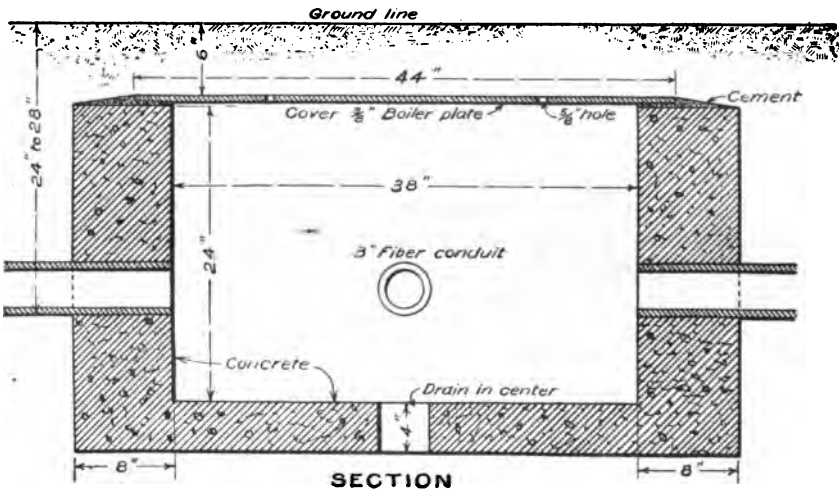
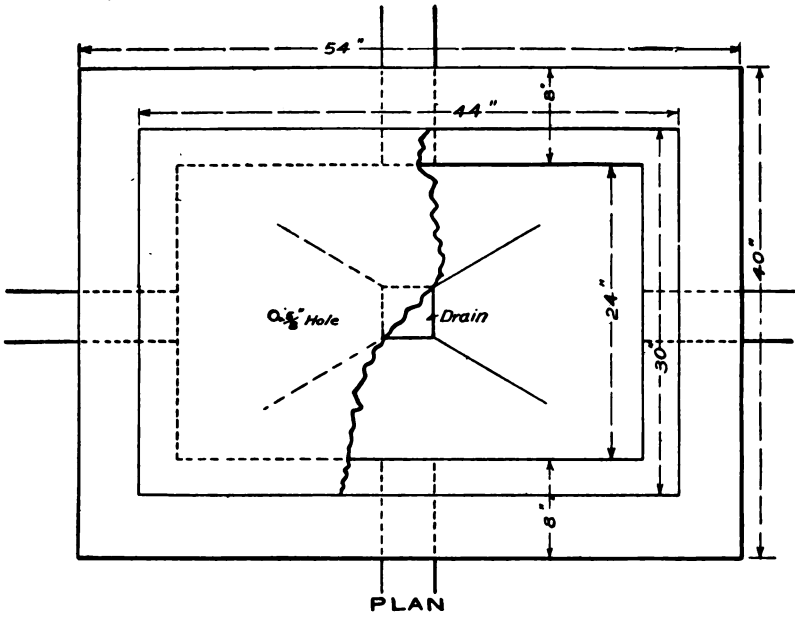

FIG. 150.—Conduit ends.

finished concrete, and allowance must be made accordingly. Thus, for 1 cubic yard of concrete by the formula 1-3-6, there will be necessary 1.1 barrels of cement, 0.46 cubic yard sand, and 0.93 cubic yard stone. One barrel of cement contains four bags. The formula is for parts by volume. The cement should be only the best grade Portland, the sand free from loam or similar foreign matter, the stone hard and sharp, screened, and not larger than will pass through a 1½-inch ring. The cement should be stored only in a perfectly dry place. The materials should be thoroughly mixed before adding water. Only such quantities should be mixed as can be placed without a delay of more than forty-five minutes. Water should be added very gradually and thoroughly mixed with the materials as applied. The materials should be accurately measured and not estimated. Mixing should be done on a board, never on the ground. The excavation for the manhole being completed, the bottom shall first be laid, extending under the manhole walls. The concrete shall be tamped in place, the surface smoothed off, and the whole allowed to set for



CONCRETE MANHOLE

FIG. 151.

six hours before proceeding with the walls. The form for the walls should now be made of good dressed lumber, substantially put together to withstand the pressure of the concrete. The forms should be so built as to be easily removed for use elsewhere. After forms are set and properly braced the concrete should be placed to form a wall of the required thickness. In some locations no outside form will be required, the earth wall serving this end. The concrete should be deposited in layers not more than 6 inches thick and rammed in place until the surface becomes slightly fluid. The manhole should be completed at one operation. A surface for the cover is made of cement and the cover placed before the cement has set. In figure 151 the cover is shown 6 inches below the surface to allow for resodding. Where this is not required the depth of the duct line below the surface may be reduced to place cover flush with ground line. In many cases where it is necessary to provide access to duct for distribution, inspection, etc., a much smaller manhole, usually termed "hand-hole," will be sufficient. This should follow the general outline of figure 151, with an inside diameter of 12 by 15 and 12 inches deep, walls not over 6 inches thick. In many cases where the hand-hole is used to end a lateral to a building, the foundation may form one side of the hand-hole. The method of construction is the same as for manholes. It is desirable to have only one size for each manhole and hand-hole, so that one set of forms will do for each type. Where concrete can not be used, recourse may be had to brick, or in emergency creosoted plank not less than 2 inches thick. Where manholes are placed in street or other traveled thoroughfare a more expensive construction is advisable, shown in figures 152 and 153. This uses a cast-iron cover of somewhat different design adapted to withstand heavy traffic. The dimensions of manhole given in this figure are not to be taken as standard. The type to be adopted depends on the number of ducts, local contours, location, etc. In this figure is shown a set of removable forms for constructing concrete manholes of this character. Where a number are to be constructed of one size it will be found desirable to use this or a similar set of forms. These should be made by local labor of rough, serviceable lumber.

The method to be used in branching from a main-line conduit to a building or group of buildings requires careful thought. Where the lateral is of sufficient length and the number of pairs requires a paper cable, a branch line of duct with a hand-hole, as shown in figure 154, should be used. The lateral cable in this case carries pairs for 3 telephones. The hand-hole is located at the wall of the central one of the group and the cable ends in a cable head, as shown. From the cable head single-pair cables are brought down to the hand-holes and are then run to each of the buildings, being trenched only after leaving the hand-hole. The height of the cable

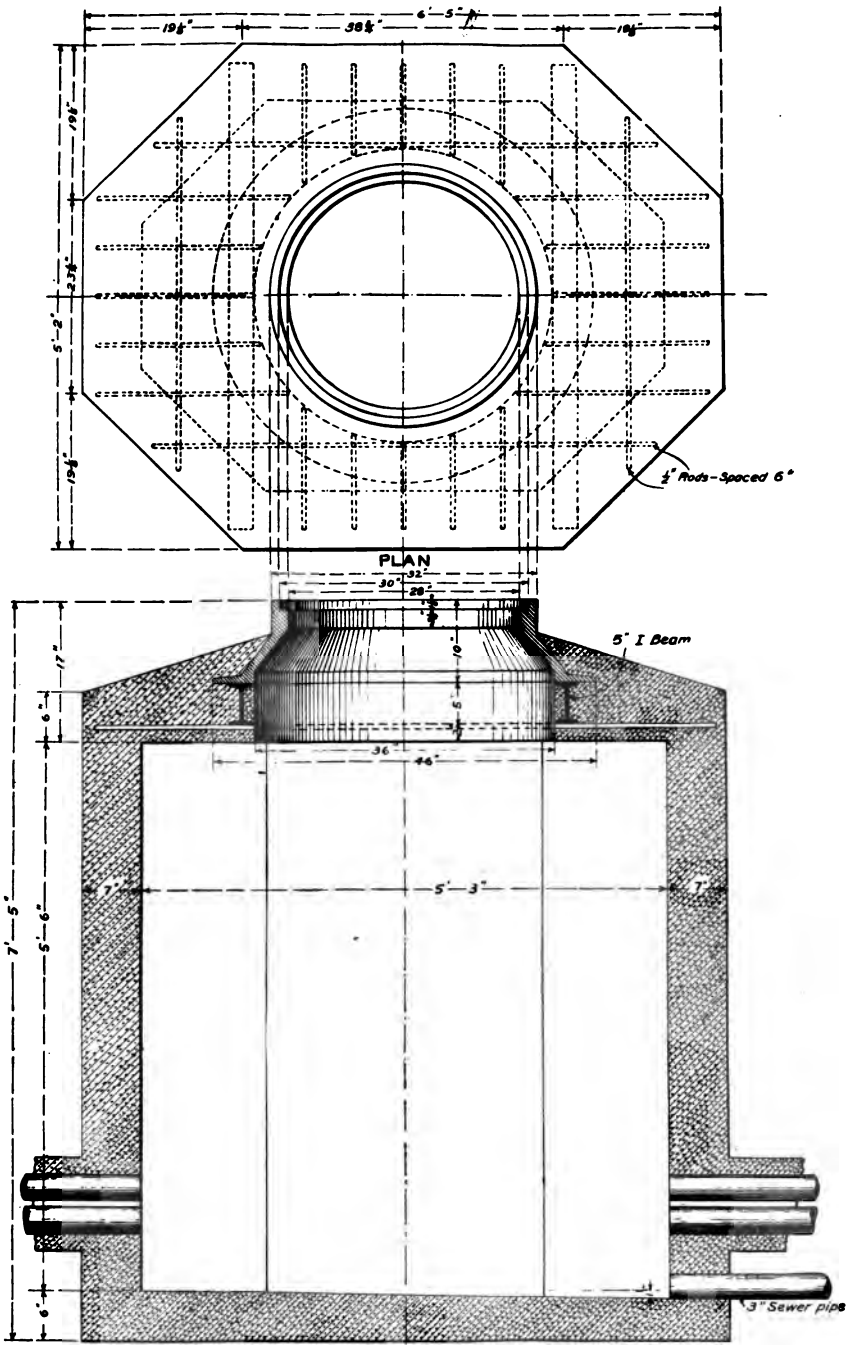

SECTION OF MANHOLE

FIG. 152.

CONCRETE MANHOLE FORM

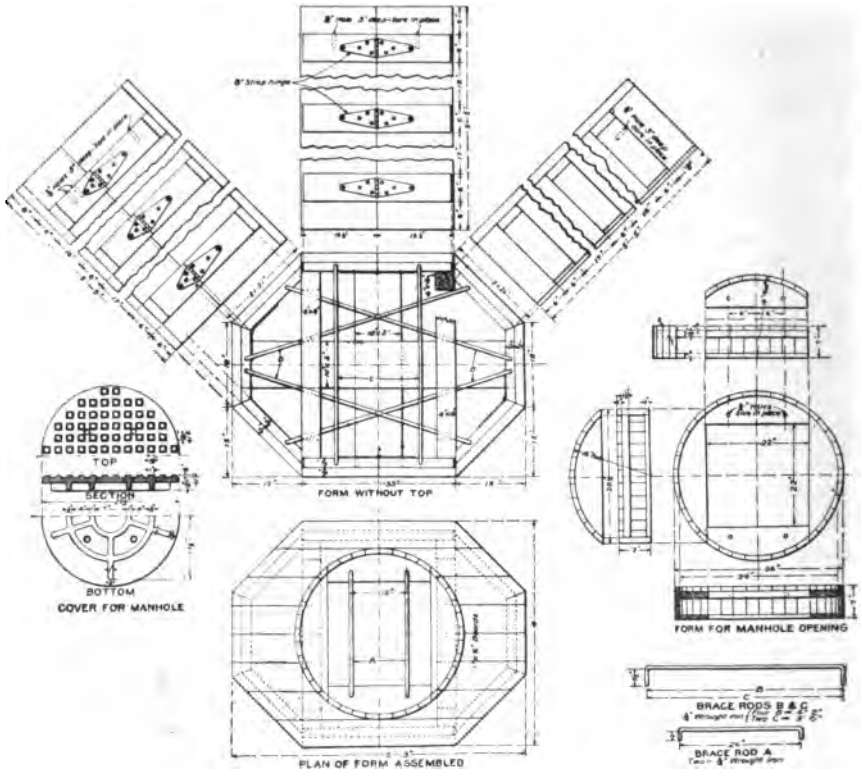

FIG. 153.

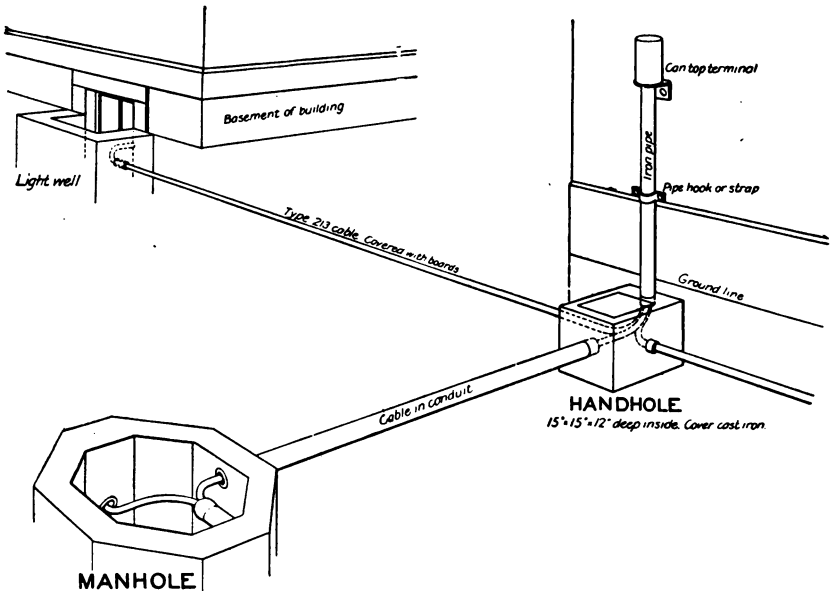
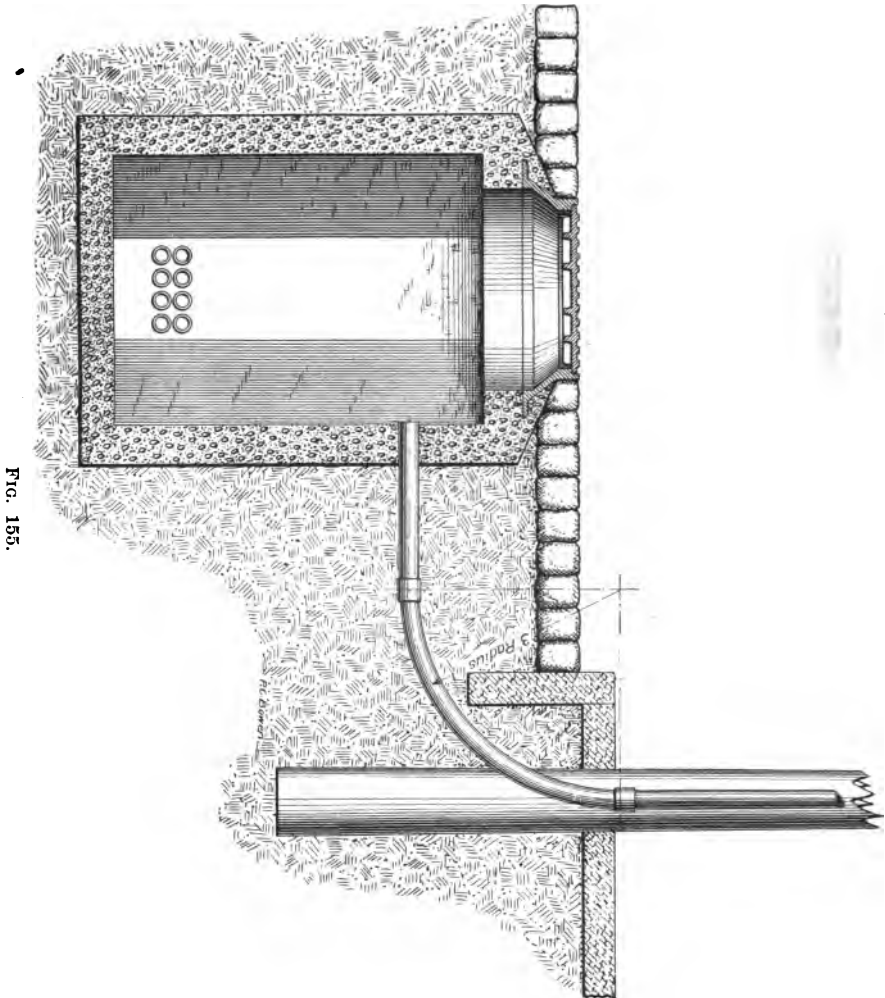

FIG. 154.

head above the ground is not fixed, but usually should not be less than 12 inches. In some cases the cable head may be placed in basements, under porches, inside storehouses, etc., where the installation can be simplified. The method of figure 154 should be followed when the lateral is 300 feet or more in length and more than one pair is required. Where the distance is less and not more than one



pair is needed, type 213 cable should be used. Connection from underground to aerial cable may be made as shown in figure 155.

PULLING IN CABLE.

The conduit system being completed, prepare for pulling in cable by threading a rope through the ducts. This may be done by means of steel wire drawn in as the ducts are laid. Where fiber conduit is

used it is possible in many cases to push this wire through after the laying is completed. Duct rods of sections 3 or 4 feet in length with coupling devices on each end may also be used. In emergency use may be made of hard-wood strips one-eighth by 1 inch cross section, notched at the ends and spliced together with iron wire. The pulling-in rope is now attached to one end of the length of wire or rods in the duct and pulled in. Now place the cable reel near manhole on jacks, as shown in figure 156.

One man tends the reel and sees that the cable feeds off freely. The man in the manhole directs the cable into the duct and prevents injury to sheath from pulling across sharp corners. The pulling-in rope may be attached to cable by the device shown in figure 157, made as follows:

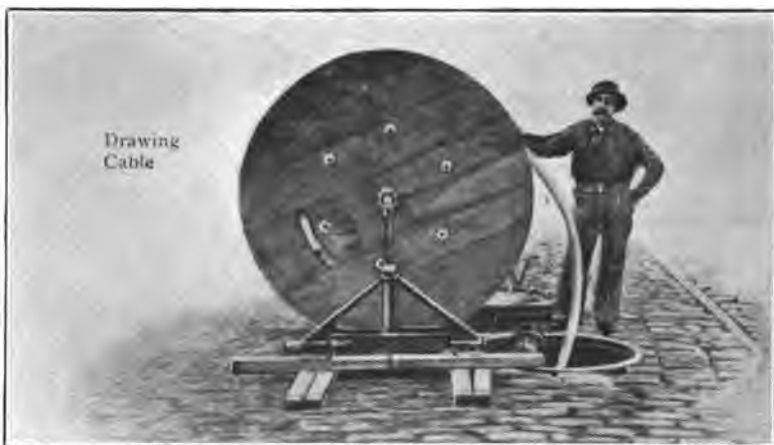

FIG. 156.

Place a block of wood about 3 inches wide against the end of the cable; cut 6-foot lengths of number 10 or 12 B. W. G. steel wire, using the rodding wire if it is in suitable condition; take two, three, or four of these wires, depending on the severity of the pull, and bunch them together, bend them in the middle on the block of wood, and then wrap the two halves spirally around the cable sheath in opposite directions, twisting the ends securely together. When the pull of the rope comes on these wires, they bind harder on each other, on the lead, the insulation, and the conductors, as the pull grows harder, and the strain is equally distributed. The seal on the lead of the cable is not broken, and no water can get to the insulation.

Manila rope is used for drawing cable, though steel rope may be used. The ends of the rope should be fitted with an eye around a steel thimble fastened to a short length of chain with a swivel. The swivel may have a pair of sister hooks, all as shown in figure 157.

If the cable is small and run short, it may be pulled in by hand. For heavy cables, winches, windlass, or horse power may be used. The rope should be led from the duct to surface over pulleys when the depth of the manhole makes a direct pull inadvisable. Two pulleys on shafts which can be inserted in any of a number of holes in two channels are used for this purpose, the lower pulley being placed opposite the duct and the upper at a height sufficient to carry the rope out of the manhole. Enough slack cable should be left in each manhole for splicing and placing the cables along the sides, leaving the center clear. After drawing in, examine all ends carefully to see that the seal is intact. Two or even three cables of the sizes commonly used in Signal Corps work may be pulled into one duct if drawn together. Pulling in a second cable with one already installed should be avoided if practicable.

The arrangement of cables in manholes

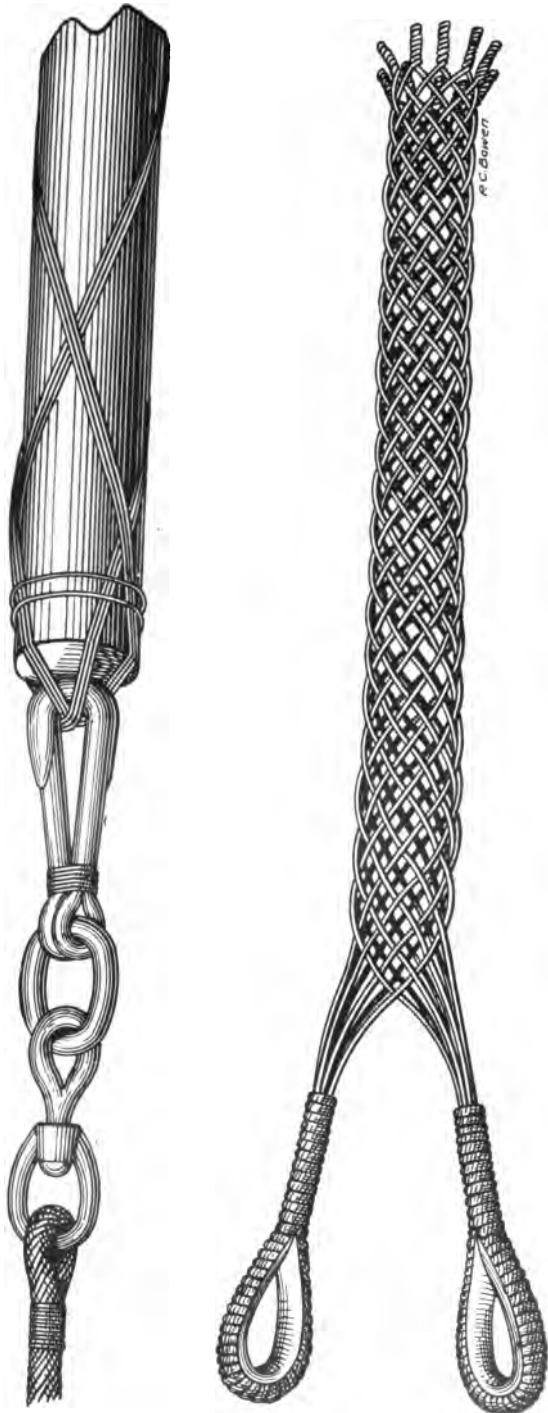

FIG. 157.

should be carefully planned to avoid sharp bends, have all cables accessible for inspection and repair and keep the center free for future operations. The cables should be supported on the side walls

CABLE RACKING IN MANHOLES

Approximate Scale: $\frac{1}{4}$ in. = 1 ft

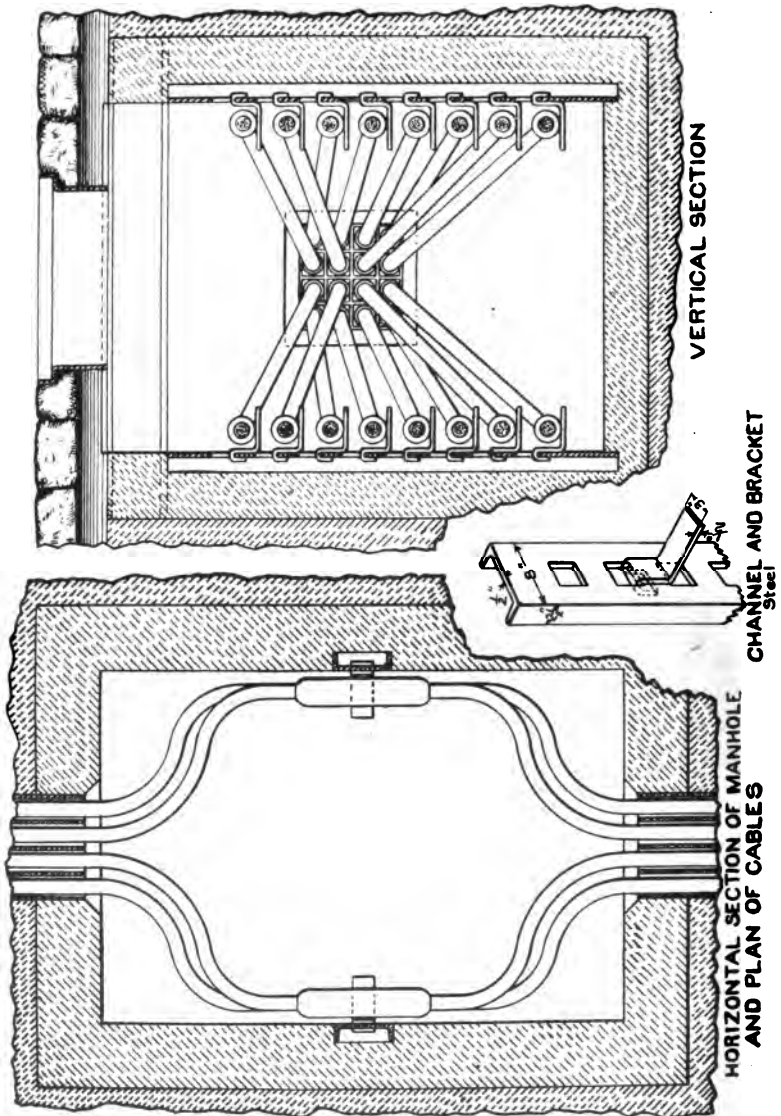

FIG. 158.

by hangers or supports of the type shown in figure 158. This figure shows the ideal arrangement for a large number of cables. Where only one or two cables are in place they may be supported by means of pipe straps attached to wall with screws and expansion anchors.

The method of splicing underground is the same as for aerial cable. The utmost precautions should be taken to prevent access of moisture to the paper core.

Type 213 cable may be run into the bulding through basement window casing or other opening in the foundation wall as may be most convenient. It will in all cases be ended on a 2-foot connecting block to which the inside wiring is also run.

Accurate record of conduit routes with manholes and hand-holes located, types and lengths of cables used indicated should be made as the work progresses.

CHAPTER VIII.

METHODS OF TESTING.

MISCELLANEOUS TESTS.

The importance of testing both for regularly ascertaining the condition of the lines with a view to anticipating breakdowns and as a means of locating faults when they occur, is something that should be recognized by all officers and enlisted men on duty at signal corps installations.

The following notes on cable testing and the location of faults where accurate instruments are not available will be found of great value where apparatus must be improvised.

The extensive use of short subterranean and submarine cables for fire-control, post-telephone, and submarine-mine systems generally makes some method of easy testing desirable. Very frequently testing sets are not on hand. If so, they are out of order or no one sufficiently skilled in their use for location of faults is available. By far the commonest class of faults is that due to defects in insulation. It is desirable to locate these in submarine cables, and very necessary in case of multiple-core cables buried in trenches or drawn into conduits, which, of course, prevents their being taken up for examination.

In the absence of better instruments, a fairly good idea of the insulation resistance of a cable may be arrived at by means of a battery and telephone receiver, as follows:

A telephone receiver (T) is connected with the battery (B) of a few cells, the latter being connected with the cable armor at C . A well-insulated wire (I) is connected with the other terminal of the telephone (fig. 159). The ends of the conductor are prepared and insulated as above described. When the end of I is touched on the cable conductor a click is heard in the receiver. If after about one second it is touched again and no click is heard in the receiver, the insulation resistance, if one cell of battery is used, is about 50 megohms; if two cells of battery, 100 megohms, and so on for about the proportion of cells.

The click produced on first contact is due to the current rushing in to charge the cable; and if the insulation is good, in one second so small an amount of this charge will be lost by leakage that little or no sound will be produced by subsequent contacts, as cable will still be

charged. Care should be taken that wire *I* and telephone terminal attached to it are well insulated, otherwise leakage from them may give false indications.

Having found the faulty conductors, the location of these faults may then be proceeded with by the methods suggested below (figs. 160 and 161). It is applicable to cables having two or more similar conductors, or to a single conductor cable when both ends are available, as when it is coiled in a tank or on a reel. It is the Murray loop test with a "slide wire," in which simple relations of resistance to lengths exist, owing to the uniformity of resistance along the wires in the cable conductors and slide wires, respectively. It is, in fact, a combination of several well-known instrument methods.

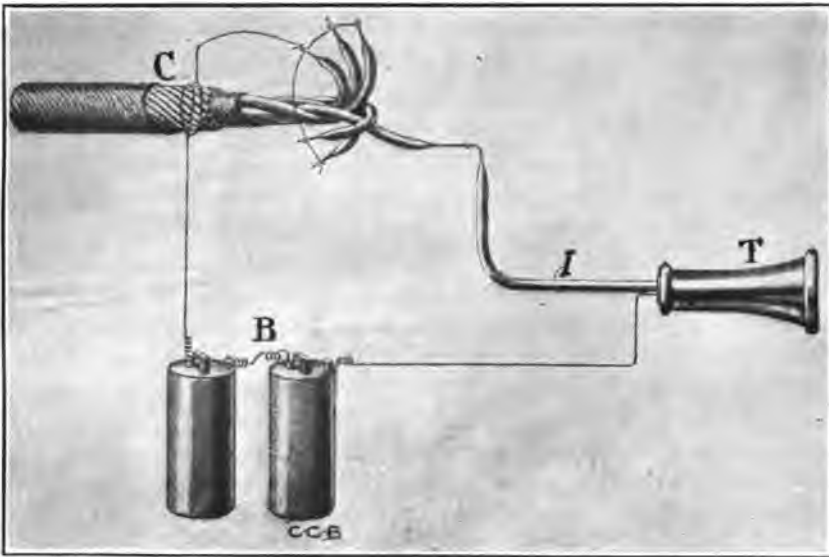

FIG. 159.

To prevent serious errors care must be taken that one of the conductors in this test has sound insulation.

No resistance measurements are involved, and the only apparatus required are a few cells of battery, a telephone receiver, and from 10 to 50 feet of bare resistance wire. Of this latter about No. 28 "Climax" or "S. B." wire is suitable. However, if resistance wire is not to be had, fair results may be obtained by using No. 36 bare copper wire.

First taking the case of a multiple-conductor cable, say 3,000 yards long, in which there is one or more conductors with defective insulation and at least one good one, join the defective one to be tested with the good one at the distant end. Drive two small bright nails (*A* and *C* in fig. 160) and convenient to the terminals of the conductors at

the testing end and stretch from these a piece of the resistance wire around another nail (D) and back, making each equal branch of the wire $A D$ and $C D$ of such a length as to be some exact submultiple of the length of the cable being tested. For example, have each branch of the wire in this case three thousand thirty-seconds of an inch long, or $1\frac{1}{3}\frac{1}{32}$ (93.75) inches. Join one of the two nails at the end of the cable terminals to the defective cable conductor, the other nail to the good conductor. Join one terminal of the telephone receiver R to the ground and the other terminal to a short wire, which will be used as a "searcher." Connect a few cells of battery B across the nails to which the cable terminals are attached. Now, putting the telephone receiver to the ear, feel along the resistance wire, which is attached to the defective conductor, with the searcher wire attached to the telephone. A point G will be found where the frying sound produced in the telephone will cease, and if the searcher

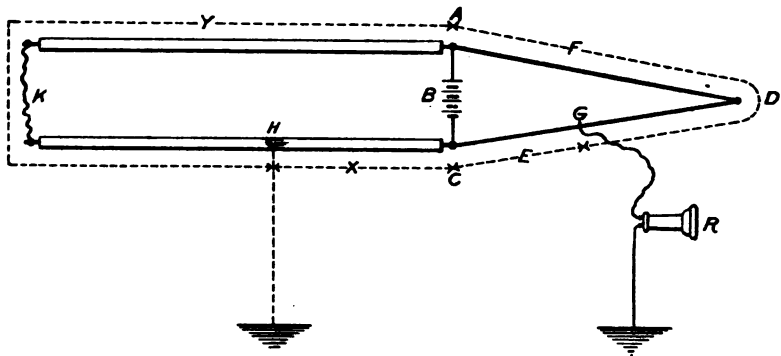

FIG. 160.

wire be moved either way from this it will again become audible. Mark this point on the resistance wire, reverse the connections of the battery, and again find the point of silence. If it is not coincident with the first, take the mean position between them.

The distance of this point G , in *thirty-seconds of an inch*, from the nail C , to which the defective cable terminal is attached, is the distance in *yards* from the cable terminal to the fault.

It is evident that for short cables greater accuracy is secured by taking larger representative units in proportion for the resistance wires. For example, if the cable were 1,250 yards long, the units on the resistance wires could be sixteenths, and the wires be convenient in length: $1\frac{2}{3}\frac{1}{16} = 78\frac{1}{2}$ inches.

Care should be taken to stretch the resistance wires evenly and not wrap the loose ends back on the stretched portion, as that would destroy the uniformity of resistances throughout the length on which the assumed proportion depends.

In testing a defective single-conductor cable the two ends are joined to the resistance wire, as just stated, the *whole length* of the resistance wire being in some simple proportion to the length of the cable.

For example, if the cable is 1,980 yards long, the whole length of the resistance wire would be $1\frac{1}{4}$ or $1\frac{1}{2}$ inches, as desired—the greater length giving the result with greater accuracy. It will be readily seen that this and the former case are identical, as the “loop” formed by joining the distant ends of two multiple conductors is in this case replaced by the “loop” of the single conductor.

The method of securing ends of wires by nails is given to show with what ease and simplicity the necessary parts for the test may be set up. But, even roughly and hastily set up, the test will locate faults with surprising accuracy if a sufficient length of resistance wire be used to eliminate small accidental irregularities in attachments of wires.

The test is a simple application of the Wheatstone bridge principle. It may be of interest to trace this out (fig. 161).

$A K$ and $C K$ are the two cable conductors joined at the distant end K . The lower one is defective at some unknown point H . The resistance wire $A D C$ is joined up as shown with the cable conductors and battery B . The point of silence in the telephone is found at G . The Wheatstone bridge relation of resistances then exists in the lengths of the wire, $X:Y::E:F$. And since these resistances are along uniform wires the same relations exist between *lengths* as between *resistances*. Consequently E can be read off directly in the terms of X if the lengths $A D$ and $C D$ are laid off numerically equal to $A K$ and $C K$.

The foregoing method involves no computation. It is evident from the above proportion that if the entire length of resistance wire were made some even number of any convenient unit (say sixteenths of an inch) that a substitution of values in the proportion would give the distances. For example, if the resistance wire had a length of 1,000 and balance were found at 432 from the end to which the faulty conductor was attached, the distance to the fault would be $432/1,000$ of the *entire* length of the conductors, or $432/1,000 \times 2$ of the length of the *cable* from the testing point.

By this method, involving simple computations, the same wire stretched on a convenient board may be used for all measurements. It becomes in effect an ohmmeter.

If more than one faulty place exists in the conductor, the test will give approximately the mean position. So, having made the test and cut the cable at the indicated place, test both ways to ascertain if both parts are not defective. If sound toward either station, the fault should be relocated in the defective part.

It will probably be found near the position of the first cut and, having allowed a reasonable percentage error, on the second cut it is highly probable the faulty section will be cut off. It has been found that generally the error of determination will fall within 1 per cent.

A word may be said regarding the telephone receiver as a detector of feeble currents. It is much more sensitive than the average pivoted galvanometer and will stand infinitely more abuse. However, in noisy places the galvanometer may be substituted for the telephone in this test to advantage.

If the fault has a high resistance, so that the four or five cells of battery permissible in the manner of connecting shown in diagram can not send sufficient current through, then some form of rather sensitive galvanometer becomes necessary with the increased battery and change of connections required. In place of the battery in figure 160, connect the galvanometer. In place of the telephone receiver, connect a battery of from 20 to 100 cells in series. Then proceed as

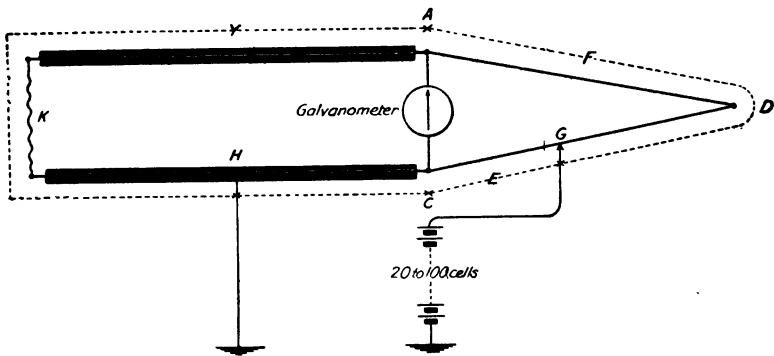

FIG. 161.

with the telephone receiver, noting that for each break or irregularity of contact of the searcher wire there may be a kick of the galvanometer, due to capacity or inductance of the current, and that balance is obtained only when the galvanometer shows no deflection when the searcher wire is at rest. (Fig. 161.)

A fault in a single conductor cable, or one involving *all* the conductors of a multiple cable, may be located if two additional wires of sound insulation between the points connected by the faulty cable are available.

As the lengths and resistances of these wires are immaterial, temporary or roundabout wires may be utilized.

The method of procedure is as follows: Stretch a single piece of resistance wire *AB* (figures 162 and 163) whose length is some even number of parts, say 1,000 sixteenths of an inch. The two sound outside wires *I* and *K* and the defective one *L* are connected at the distant end. The galvanometer, battery, and searcher are connected, as

shown in figure 162, and the point of balance obtained. Call the reading A from the point C .

Then connect up as in figure 163, joining the battery to earth or to the cable sheath. If the fault appears as a leak between two adja-

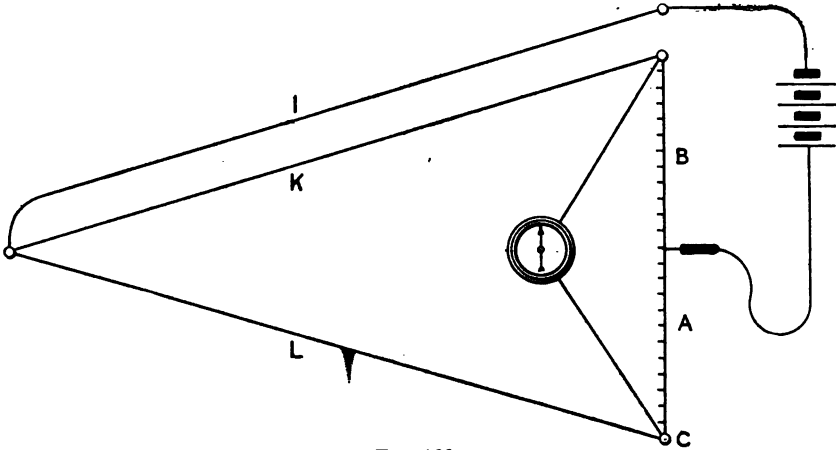

FIG. 162.

cent wires of the multiple cable, the lower end of the battery should be joined to the other faulty wire instead of the cable sheath or ground.

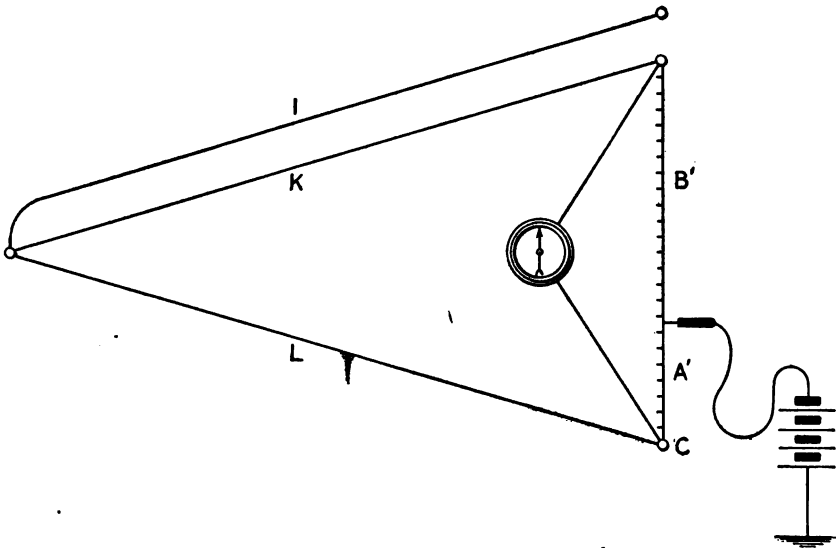

FIG. 163.

When balance is obtained, note the reading on the resistance wire from point C . Call it A' . Then if length of faulty conductor is L feet, the distance of the fault from C is $\frac{A' L}{A}$ feet.

This method is particularly applicable to paper cables where a leak has made the insulation of all the conductors faulty.

Location of break in conductor.—The method applicable when the wire is broken inside the insulation, leaving the latter intact, is given below. This is the character of the fault generally produced when a conductor parts in a paper cable. Owing to the small capacity of this kind of cable the method is useful because of the practical difficulty in getting correct capacity values by galvanometer methods in small lengths of this cable.

The connections for the test are the same as that described in figure 161, except the telephone receiver is used in place of the galvanometer. The point *H*, instead of representing a fault in insulation, in this case represents the location of a break in the wire. It is best to use quite a number of cells, say 20 or 30, if available. The battery circuit is reversed and interrupted rapidly while a point is sought with the

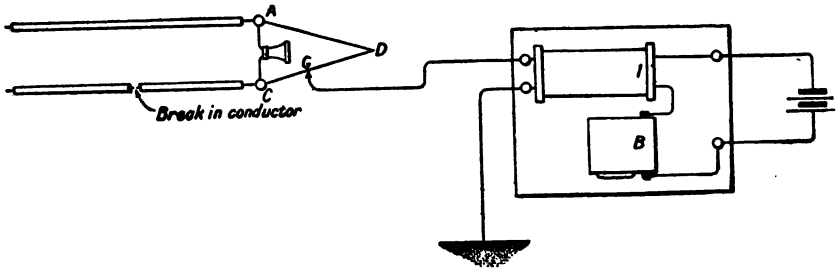

FIG. 164.

searcher along the resistance wire where the clicks are no longer heard in the receiver. When this point of balance is reached the distance to the break is then read off on the scale along the resistance wire from *C* to the point *G*, as explained in locating insulation faults. In this case the point *G* is in the corresponding position on the upper wire.

In the last-named test an interrupted current of rather high voltage is required. A method of getting this with only two dry cells is to take a local battery telephone induction coil (*I* in the figure) and attach it to a wooden base, together with an ordinary small metal buzzer "*B*."

The connections are as shown in figure 164. When the battery is connected the buzzer sends a vibratory current through the primary coil. A vibratory current of much higher voltage is induced in the secondary, and this is utilized in place of the battery currents, as shown in the foregoing tests.

THE VOLTMETER AND AMMETER.

On land telegraph lines and the apparatus connected therewith the electrical units with which we are usually concerned in measurements and tests are those given in Ohm's law—the current in amperes equals the electromotive force in volts divided by the resistance of the circuit in ohms; expressed algebraically $C = \frac{E}{R}$. The galvanometer, in one or the other of its forms, measures current. When of low resistance and graduated properly, it is called an amperemeter or ammeter. When of high resistance, since the current flowing through it is practically independent of the relatively small variations of outside resistance, the galvanometer readings are directly proportional to the electromotive force E . And when properly graduated it becomes a voltmeter. The ammeter and voltmeter, on account of portability and quickness and accuracy with which readings are taken, are very sat-

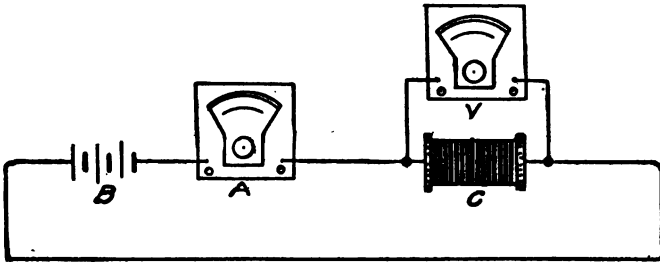

FIG. 165.

isfactory instruments for telegraph testing. It is evident if C and E are measured by an ammeter and voltmeter, respectively, that R becomes known—for Ohm's law may be written $R = \frac{E}{C}$. For example,

if we connect the ammeter A , battery B , and a resistance coil C together, as in figure 165, we may read the current flowing. The small current commonly used in telegraphy is conveniently expressed in milliamperes, and the ammeter graduated for these is called the milli- or mil-ammeter. If we attach a voltmeter V to the terminals of the resistance coil C , it will give the difference of potential (E M F) produced at these two points by the current flowing between them.

Suppose the milliammeter reads 28 milliamperes (0.028 ampere)

and the voltmeter 4.23 volts. Substituting in $R = \frac{E}{C}$, $R = \frac{4.23}{.028} = 151$

ohms. The general rule in connecting up the ammeter and voltmeter for such measurements is to put the ammeter in the circuit, and the voltmeter shunting the part of the circuit whose resistance is desired. The practical use of the instruments in testing telegraph lines is given below.

The theoretical connections are shown in figure 166, the voltmeter being connected in shunt to line and ground, and the milliammeter in series in the circuit. The correspondence of this with figure 165 will be noted. The practical connections are shown in figure 167.

A portable voltmeter reading to 200 volts (V), and milliammeter reading to 150 milliamperes (A), are mounted on a board and con-

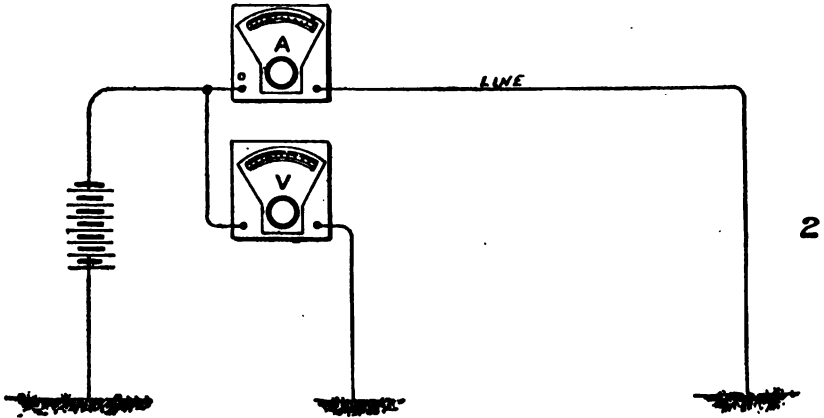

FIG. 166.

nected with the regular switchboard cord and wedge, as shown, the other terminal of the voltmeter being connected with the ground.

When the wedge is inserted in any line spring jack, the ammeter is connected in the circuit and the voltmeter shunted to the ground, as shown in figure 167. The deflections of the ammeter and the voltmeter thus give C and E in the formula $C = \frac{E}{R}$ and the third, (R), becomes known.

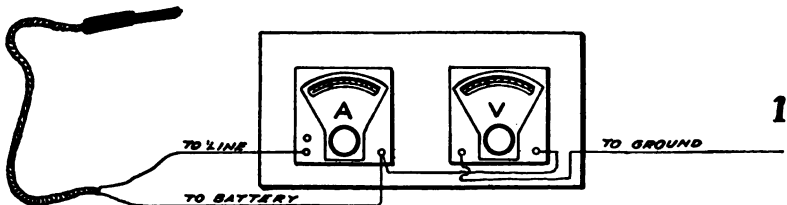

FIG. 167.

To test, cut off battery at most distant station, ground line, and take readings. Now open the key for a few seconds and take a second set of readings. Repeat this process with all stations up to the nearest one. The readings with stations grounded give resistance of line (including relay) to each, while readings with the keys opened would give the insulation resistance to each.

The following instructions show some methods of using the voltmeter alone for various measurements when the ammeter is not available:

THE VOLTMETER (0-5, 0-150 VOLTS PATTERN).

This instrument is a galvanometer of the D'Arsonval class, in which a pivoted coil, controlled by a spiral spring turning in jeweled bearings, carries a light aluminum pointer moving over an equally divided scale.

This coil turns, when a current passes through it, in the strong field between the poles of a powerful permanent magnet. In the base are two resistance coils, one or the other of which is always in series with the movable coil, depending upon which scale is used—the 150 or 5 volt scale.

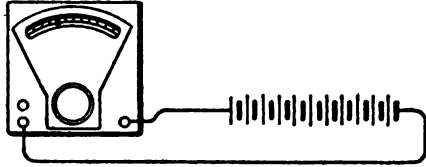

FIG. 168.

Caution.—To prevent bending the pointer by violent action, always test first with the 150-volt scale. If the pointer indicates less than 5 volts, use the other binding post and take advantage of the greater accuracy of the 5-volt scale.

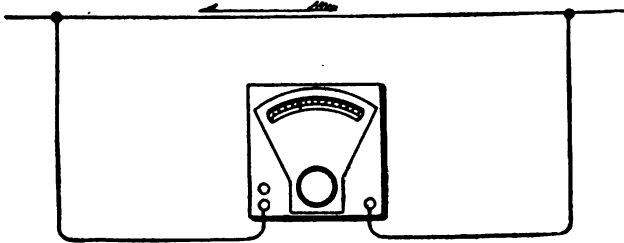

FIG. 169.

TO TEST THE VOLTAGE OF A BATTERY OF A NUMBER OF CELLS.

Use the 150-volt scale and connect up as shown (fig. 168).

For not more than 3 sal ammoniac, 4 bluestone, or 2 storage cells in series use the 5-volt scale.

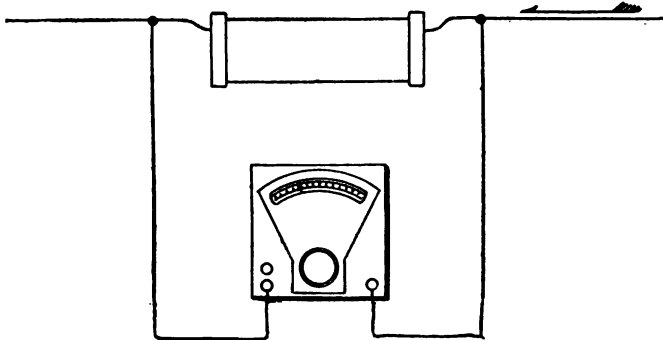

FIG. 170.

TO MEASURE THE DIFFERENCE OF POTENTIAL (PRESSURE) BETWEEN ANY TWO POINTS OF A WIRE OR EXTREMITIES OF A COIL CARRYING A CURRENT.

The connections indicated in figures 169 and 170 would give the differences of potential at the two points on the wire, or at the extremities of the coil, respectively.

TO MEASURE A RESISTANCE.

To measure a resistance less than 3,000 ohms use two or three dry or Gonda cells in series, get their voltage, using the 5-volt scale. Call this V . Then connect up with the unknown resistance X (fig. 171), as shown, and call this scale reading V' .

The resistance of the voltmeter, using 5-volt scale, is given in the sliding cover of box. Call this R .

Then

$$X = \frac{R(V - V')}{V'}$$

This is very inaccurate for resistances of only a few ohms unless the resistance of the battery is taken into account.

In measuring resistances from 3,000 to 250,000 ohms use the 150 scale, noting the value of R given on the cover for this. The same connections and formula are applicable.

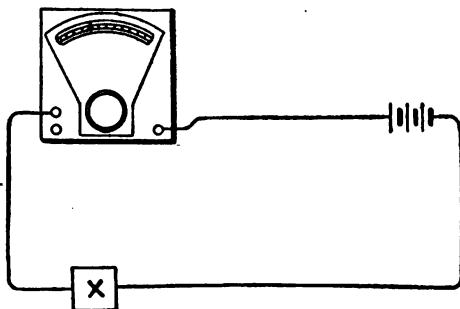

FIG. 171.

To secure greater accuracy in either of above cases, the battery should have sufficient E M F to bring the value of V as near 5 or 150 as practicable.

Example.—(1) Using 5-volt scale. Resistance to be measured (X) is an ordinary telegraph relay magnet.

Suppose $R=520$. Three cells dry battery in series give $V=4.35$ volts. When X is connected in, $V'=3.40$.

Then

$$X = \frac{520(4.35 - 3.40)}{3.40} = 146 \text{ ohms.}$$

(2) Using 150-volt scale. Determine the insulation resistance of 110-volt storage battery (leakage from either pole of battery, or its connections, to earth).

Suppose R for this scale = 15,500 ohms. Voltage across terminals, $V=110$ volts; voltage between one of the terminals and earth (V') = 12 volts.

$$X = \frac{15,500(110 - 12)}{12} = 126,583 \text{ ohms.}$$

This would indicate a slight leak, probably at or near the negative end of battery if the tests were made at the positive terminal.

If some coils of known resistance are available, resistances can be measured more accurately as follows:

The known coil and the resistance to be measured, marked respectively r and x , are connected with each other and a battery, as shown (fig. 172). The

voltmeter is connected first as indicated by the full, and then as by the broken lines. If the voltage indicated in the first case is E and in the second it is E' ,

$$E : E' :: r : x. \therefore x = \frac{E'r}{E}.$$

Use enough battery to make a good readable deflection, and if several known coils are available use the one which is somewhere near the resistance to be measured.

Example.—Known coil, 10 ohms. Voltmeter shunting this gave 3.2 volts, and shunting the unknown gave 4.7 volts. Hence

$$x = \frac{4.7 \times 10}{3.2} = 14.7 \text{ ohms.}$$

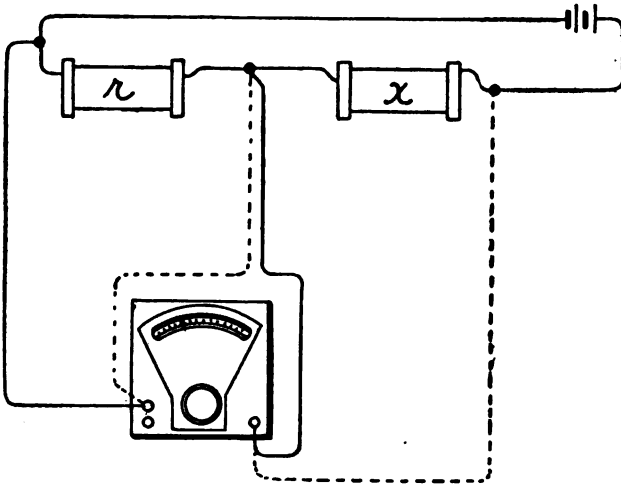

FIG. 172.

TO MEASURE CURRENT WITH THE VOLTMETER.

If we know the resistance of a wire or coil, and have a steady current flowing through it, the voltmeter wires applied at the terminals of the wire or coil will give a certain deflection, E . Hence, since $C = \frac{E}{R}$, if we substitute for E and R the known values we get C . (Connections shown in figs. 169 and 170.)

Example.—A certain current is flowing through a 4-ohm telegraph sounder. When the wires from the voltmeter (5-volt scale) are connected at sounder binding posts, the voltmeter indicates 0.8 volt.

Substituting as above,

$$C = \frac{.8}{4} = .2 \text{ ampere.}$$

TO MEASURE THE INTERNAL RESISTANCE OF A BATTERY.

Using the 5-volt scale, first take the voltage of the cell. Then take the voltage at the terminals of a coil of rather low resistance (a 4-ohm sounder, for instance), in circuit with the cell (fig. 170), being careful not to close battery

circuit until ready to read the voltmeter. Multiply the voltage of the cell by the resistance of the coil and divide by the voltage at terminals of coil. From the result subtract the resistance of the coil. The remainder is the internal resistance sought.

Example.—The voltage of a dry cell is 1.41, and the voltage at terminals of 4-ohm sounder in circuit with the cell is 1.24.

$$1.41 \times 4 \div 1.24 = 4.5.$$

$4.5 - 4 = .5$ ohm, internal resistance of cell. Care must be taken to read voltmeter quickly after closing the circuit through coil, or the result will be vitiated by the polarization of the cell.

THE WHEATSTONE BRIDGE.

This has long maintained its position as the best means for measuring resistances, and in one or the other of its various forms can be used for a great range of measurements.

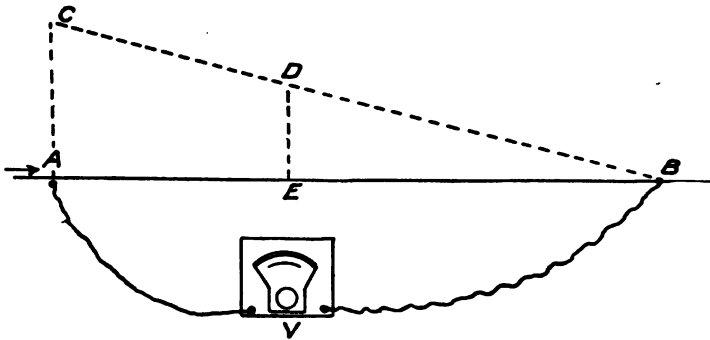

FIG. 173.

The "fall-of-potential" principle is applied, which may be illustrated as follows (fig. 173):

If a current is flowing along a wire in the direction of $A B$, and the terminals of a voltmeter V are applied at A and B , a certain potential difference between these points will be indicated; that is, there will be a fall of potential from A to B , which will be uniform if the wire is of uniform resistance. This may be represented graphically, for if the height of $A C$ represents the total difference of potential, and the line $C B$ represents the fall of this to B along the uniform wire, then at any point, say at E , the height $D E$ will represent the potential difference between B and E , which is proportional to the length of wire or resistance remaining.

If we take a circuit divided at A (fig. 174), the fall of potential along the wire $A E B$ is equal to that along the wire $A G' B$; and having passed over a certain proportion of the total resistance $A E B$, if we join the point E through the galvanometer (voltmeter) with a

point G' , where the same proportional part of resistances $A G' B$ have been passed over, E and G' will be of the same potential, and no current will pass through the galvanometer. It can be proven that when the resistances of the divided circuit bear this proportion— $A E : A G' :: E B : G' B$ —the points E and G' are at the same potential with respect to each other and the galvanometer will not be deflected.

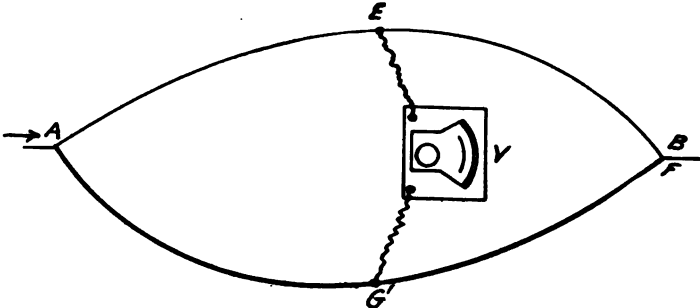

FIG. 174.

The relation of parts in the conventional diagram of the Wheatstone bridge (fig. 175) will now be apparent. If the resistance in the coils of A and B are equal or bear any other simple numerical relation, then the same numerical relation exists between R and X , and if R be a box of known resistance coils, X , the unknown resistance, becomes known from the above-stated relation $A : B :: R : X$.

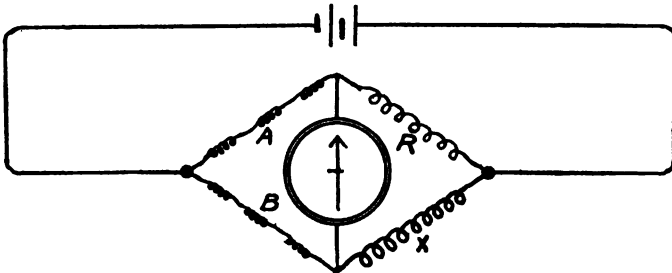

FIG. 175.

If we straighten out A and B and bend up R into compact form, put keys into the galvanometer and battery circuits, we shall have the diagram of the ordinary or "post-office" form of the bridge (fig. 177). The resistance in the "balance arms" A and B , and in R are short-circuited by inserting the plugs, and they are introduced by withdrawing the plugs. The galvanometer now most usually employed is some sensitive form of the suspended-coil type.

The simplest measurement is made with A and B equal. Start out with, say, A and B 100 ohms each. Then connect up the terminals

of the unknown resistance X ("line" and "ground"), and closing the battery key, tap the galvanometer key. There being no resistance unplugged in R , the galvanometer needle will be deflected to the side indicating "too small" for R . Now unplug in R and test until the right amount is unplugged in R to get a balance or no deflection.

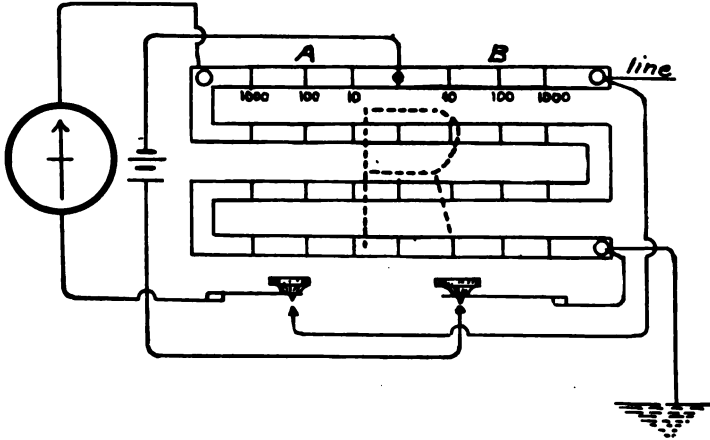

FIG. 176.

Always close battery key before galvanometer key and open galvanometer key first; then, since $A=B$, $R=X$. If fractional ohms are to be obtained, A must be 10 or 100 times greater than B ; then R is 10 or 100 times greater than X . Likewise, if X is greater than can be obtained by unplugging in R , then make B the greater and it reverses

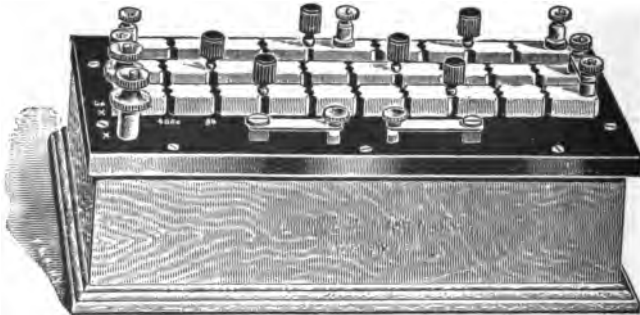

FIG. 177.

the multiplier. Practice and care are requisite to obtain accurate results.

In measuring resistances of a telegraph line be certain all line batteries are disconnected before making the measurement. The line is connected with one of the X binding posts, the ground to the other. (See fig. 176.)

Many modifications of this form of bridge are in use. Some are arranged so the plugs are inserted at the points where the introduction of resistance marked is desired.

One of the familiar forms in which the bridge is made for laboratory use is shown in figure 177. In this the resistances are introduced by taking out plugs. The further row of strips are for the *A* and *B* arms, the other rows constituting the *R* arm. The keys are for introducing battery and galvanometer into circuit.

The following graphical demonstration of the stated proportionality of the resistances in the four arms of the Wheatstone bridge when balance is obtained is of interest in connection with the foregoing:

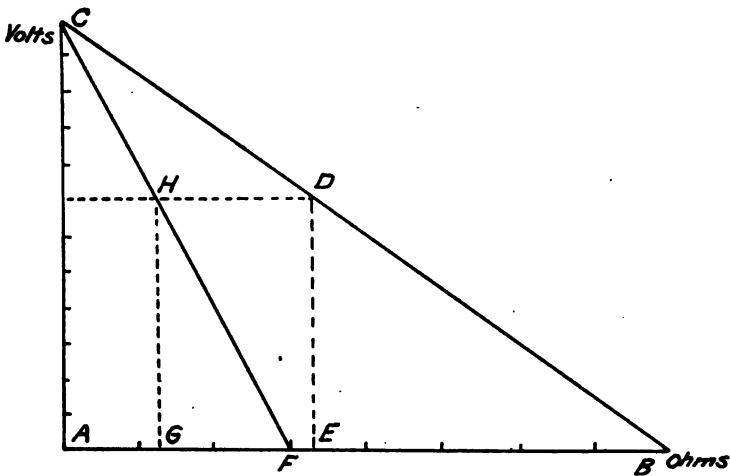

FIG. 178.

Lay off *AB* to represent the resistance in the upper branch of the bridge (fig. 178) and *AF* to represent resistances in the lower. Let *AC* represent the difference in potential between the two ends of the bridge, and draw lines *CB* and *CF*. These are the "fall of potential" lines along the upper and lower branches respectively.

A horizontal line *HD* touches points *H* and *D* at the same potential. These projected on lower lines represent the points of galvanometer connection. The resistances passed over in lower and upper branches to reach these points of equal potential, measured on the lower line, are *AG* and *AE*.

Similar triangles give these proportions:

$$CD : DB :: AE : EB$$

$$CH : HF :: AG : GF$$

$$CD : DB :: CH : HF$$

$$AE : EB :: AG : GF$$

$$AE : AG :: EB : GF$$

F and B being at the same point in the conventional diagram of the bridge (fig. 174), the last proportion will be seen to be identical with that accompanying that figure.

The wide range of resistances that can be measured with a Wheatstone bridge has caused it to be likened to a pair of scales which may be converted from hay scales to a chemical balance. It has been noted that when the "balance arms" are equal the resistances of standard coils and measured resistances are equal; and by changing the ratio of these balance arms, which correspond to shifting the fulcrum in the steelyard, the standard resistance may be made to bear any desired ratio to the measured resistance.



FIG. 179.

ELECTRICAL INSTRUMENT CASE.

The electrical instrument case is shown in figure 179.

It consists of a strong oak box containing the necessary apparatus for making the standard tests. The equipment includes:

- A portable reflecting galvanometer with tripod.
- A capacity testing set.
- An insulation testing set.
- An ohmmeter.
- An inspector's pocket kit.
- A micrometer caliper.
- Service testing battery.
- Spare parts.
- Instruction memoranda.

The apparatus contained in it, with the exception of the inspector's pocket kit, service testing battery, micrometer, and ohmmeter, is intended for special testing only.

Each case is supplied with a complete line of spare parts, making it possible to repair any instrument contained in the case, so that no delay in testing can be excused because of defective instruments.

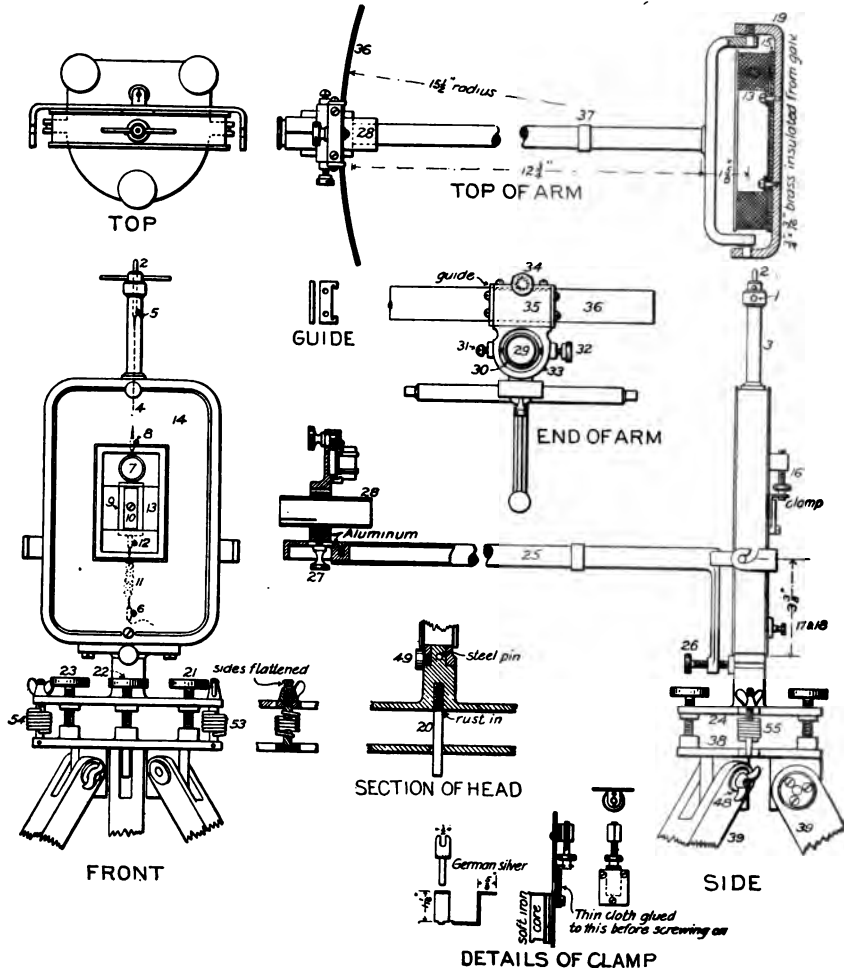

FIG. 180.

These cases are never used where tools are not available, but it is assumed that they will frequently be used at points remote from the instrument repair shop. The data herein, together with the descriptive matter, which forms a part of the case, cover all the necessary information for making emergency repairs. In addition to the standard list of parts, shown on page 258, the case should always be supplied with an ample quantity of cable blanks and cable tags.

THE GALVANOMETER.

A reflecting D'Arsonval galvanometer is supplied, arranged for mounting on a tripod. It is provided with a short insulated telescope arm and an optical system, which magnifies the image of the scale. Owing to this magnification, it is necessary to mount the instrument on a solid floor or to provide against jars while testing, which tend to make the image indistinct.

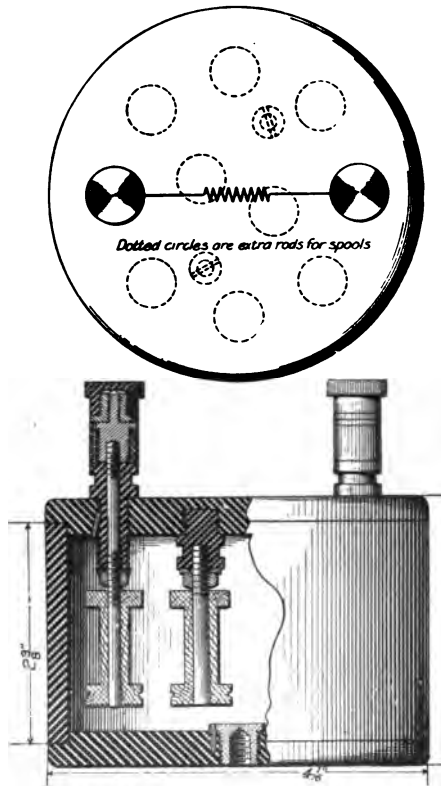

FIG. 181.

As in all the instruments of this type, the frame is on one side of the circuit, and the tripod legs should be wiped thoroughly dry before making a test. This precautionary measure should always be taken.

The sensibility of this instrument is 300 megohms. This is determined by the fact that one volt through one megohm will deflect the mirror 300 scale divisions. Figure 180 shows the construction of this instrument.

100,000-OHM BOX.

The 100,000-ohm box is a circular rubber case having mounted therein 10 coils wound with No. 40 B. & S. manganin wire. Should

trouble occur with this device the proper-sized wire will be found in the spare-parts case. This box is held together with two screws. (Fig. 181.)

COMBINED SHUNT AND KEY.

This shunt and key, or button, takes the place of the usual Ayrton shunt, battery key, and short-circuit key. Its connections and general construction are shown in figure 182.

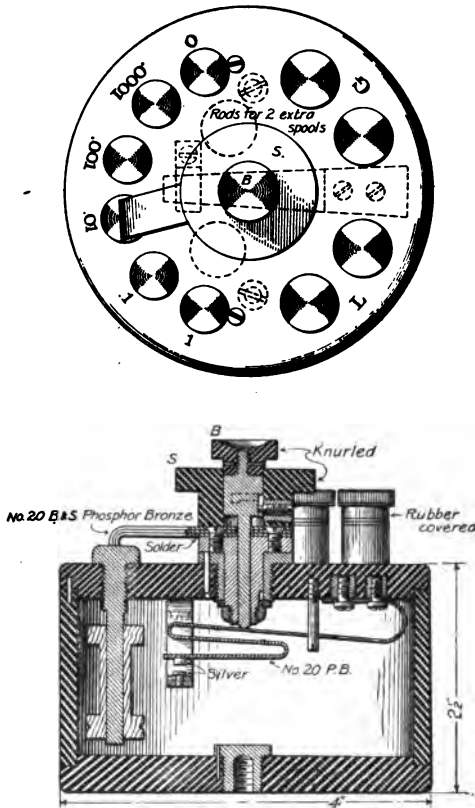

FIG. 182.

The key is provided with a bayonet joint. The shunt should always be on 0.0001 at the beginning of the reading, and the lower button is then turned until a readable deflection is obtained.

The button *B* controls the battery, and the button *S* controls the shunt.

This method of operating the galvanometer insures against sudden heavy currents, and consequent violent disturbance of the moving system incident to low insulation, and dispenses with the short-circuit key.

STANDARD CONDENSER.

The standard condenser set consists of a one-third microfarad non-adjustable condenser, with a key for its operation, and the necessary binding posts and plugs, as shown in figure 183. Its connections are also shown in the figure. By moving the switch *S* to the right either the cable or condenser may be charged, depending on the location of the plug. The condenser is best-grade mica, with resin and beeswax filling.

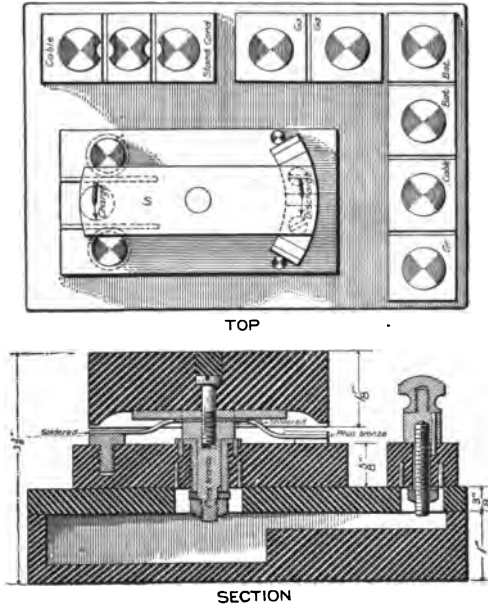

FIG. 183.

SERVICE-TESTING BATTERY.

The service-testing battery consists of 100 cells of small dry batteries. (Fig. 184.) They should be examined once a month.

The battery is tapped for 5, 10, 25, 50, 75, and 100 cells. When new it should give an E M F between 140 and 150, and should not drop below 100 within a year. When certain cells show deterioration, they should be removed and the circuit restored. New cells throughout should be requisitioned for when a majority of the cells show discoloration and the voltage of the whole battery is under 80 with all connections in good order and the poorest cells cut out.

Care must be taken to keep the battery connections clear of short circuits, as the high voltage of these small cells will cause a heavy current to flow and ruin the battery very quickly if connected to a circuit of low resistance.

OHMMETER MODEL, 1904.

The ohmmeter furnished with this case is a compact form of the original model ohmmeter. The variable resistance is wound on a cylinder so arranged as to be divided into 1,000 equal parts by a horizontal scale of 20 equal parts and a drum scale of 50 unit parts. The reading obtained from the stylus is arbitrary, and reference is had to the table in the cover of the instrument for the actual resist-

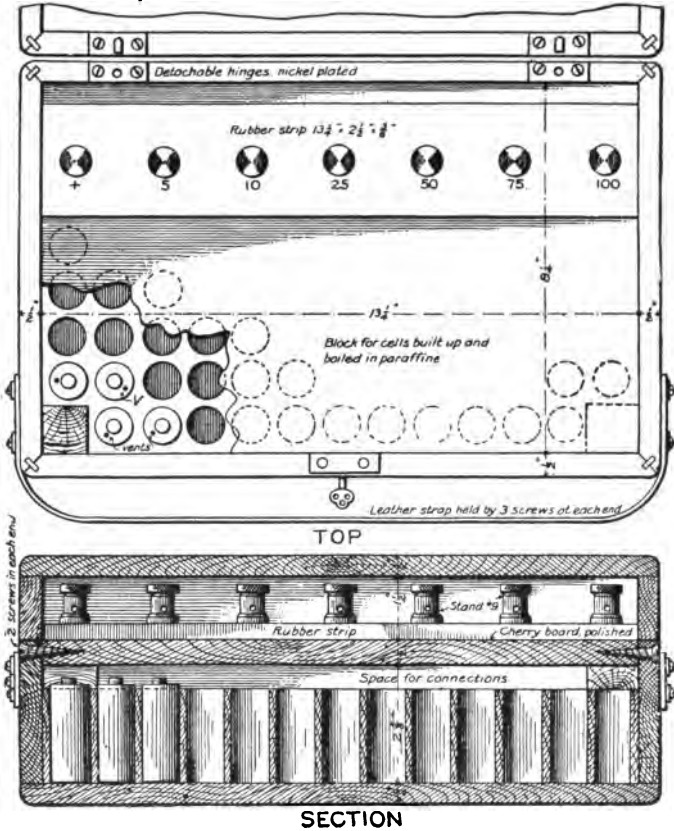

FIG. 184.

ance corresponding to any given position of the stylus. (See fig. 185.) The battery key has a bayonet catch.

METHODS OF USING ELECTRICAL INSTRUMENT CASE.

The tester should have at least two assistants. One should be a man familiar with electrical apparatus. Two men should be used to transport apparatus. If both ends of the cable to be tested may be readily reached by the entire party, a detail of two should be suffi-

cient. If cable ends are remote, the cable tester should take two men with him and send the most experienced man to the distant end of the cable.

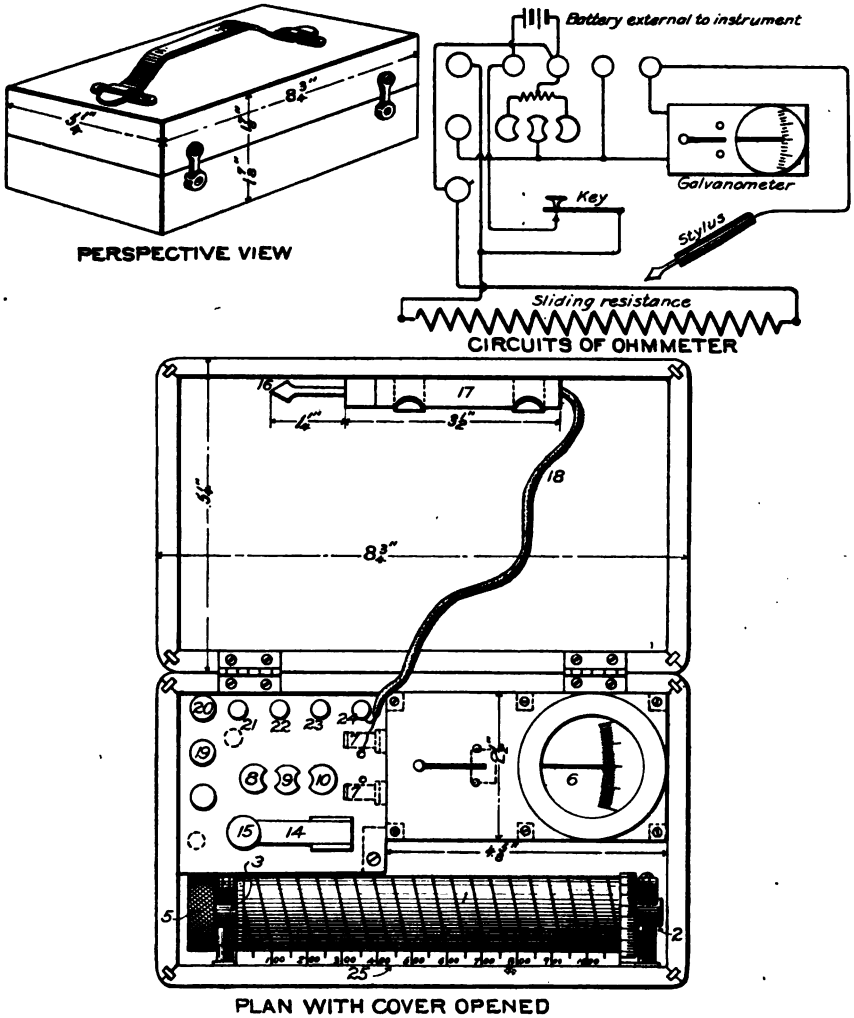

FIG. 185.

DUTIES OF MAN AT DISTANT END.

The distant man should be instructed to clear the ends of all conductors, scraping them carefully, and taking care to keep them dry and clear of each other and ground. If the cable has rubber insulation, he should pencil the insulation into a cone shape (fig. 187) to give the maximum value to the surface area of the ends of the conductors, thus avoiding leakage. He should then connect his receiver

to a designated conductor of the cable, with one other conductor in parallel, or with all the conductors in parallel and with ground or sheath. Having cleared his ends and made this connection, he should wait for a call, and under no conditions disconnect or change this arrangement after he has satisfied himself as to its correctness. He should be supplied with a bundle of tags, properly marked, with tape for closing up the ends, and, if he has sufficient skill to do so, the necessary torch, iron, and solder for closing up the end of a lead-covered cable. Cable should always be sealed, however, by a man who understands this work, and no risk should be taken regarding the condition of the cable ends after the tests.

DUTIES OF TESTER.

The cable tester should proceed to the more convenient end of the cable with his testing instruments and set them up.

The galvanometer should be set up, as described previously, in such relation to the strongest light that the scale is most illuminated while the mirror is in the shadow. The box containing the insulation and capacity-testing set should be placed on a dry foundation. The 100,000-ohm box should be wired permanently into circuit, to avoid dangerous currents on the testing battery, and also be placed on a dry support.

While the tester is setting up the instruments his men can get the cable ready, as described, for the distant station and attach a bare copper wire to all the conductors.

CONTINUITY AND IDENTIFICATION.

The tester then connects a telephone receiver to the bare wire and to ground and calls his assistant at the distant station. The cable conductors are then identified by the tester connecting his telephone on No. 1 and instructing his assistant to find him. Should an open wire occur the tester may get his assistant by disconnecting from the wire he wishes located and connecting to the bunched wires.

All wires not under test should at all times be kept bunched at the testing end. Except when testing for copper resistance, all wires, except the talking wire, should be kept free at the distant end.

It is to be noted in this connection that the capacity of long cables, especially if rubber insulated, may make it possible to ring a magneto or carry on conversation between entirely separate conductors. The absolutely certain test for continuity or identification is obtained by placing a battery and indicator, such as a galvanometer, voltmeter, buzzer, or telephone receiver, in series to ground, and testing with the free end of the circuit. An indication can then be given only by a flow of current over a complete electrical circuit.

The two conductors of a pair should always follow consecutively, so that each pair consists of a wire having an even and a wire having an odd number. If the cable has straight wires, the odd wires are numbered last. Numbering usually proceeds from the core outward. The tags should be clearly marked and carefully attached to avoid danger of removal during subsequent construction work.

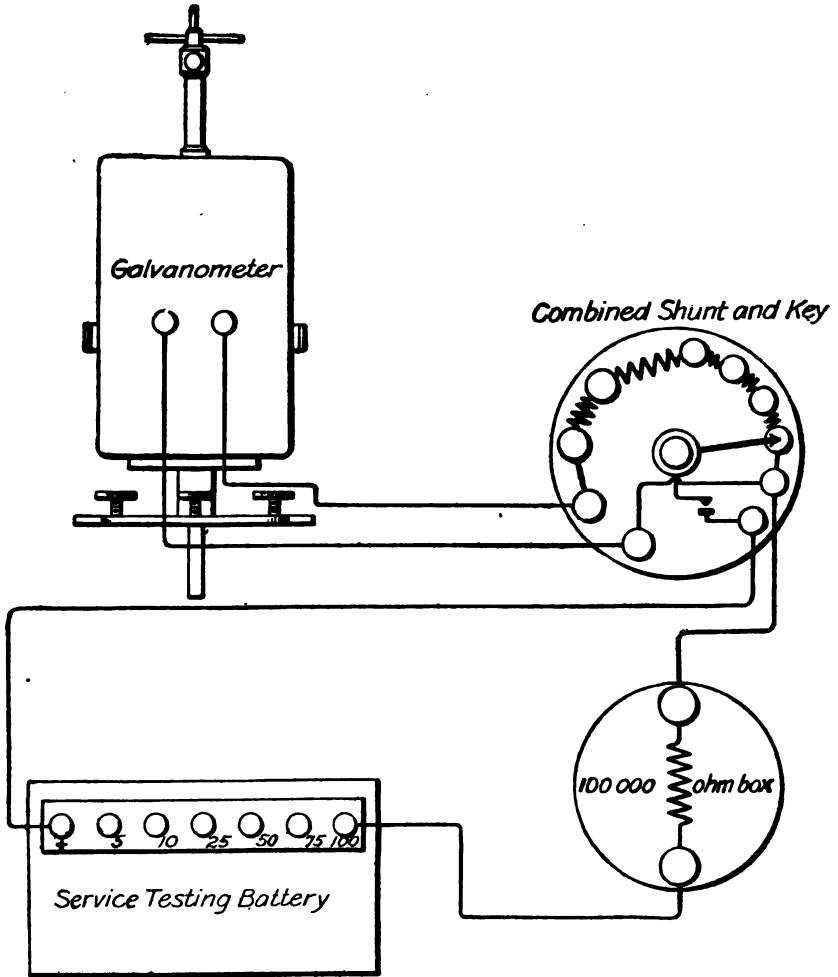

FIG. 186.

Having identified all conductors, the tester instructs the assistant to see that all wires are clear, except the telephone, and then to report. When all are reported clear, the assistant may be instructed to stand by and await orders; under no conditions to try to signal or to touch wires unless told to do so.

CORRECTION FOR LEADS, AND TEMPERATURE.

On preparing for readings of insulation, capacity, and copper resistance, readings should be taken for each of these values on the leads and recorded for correction of the respective test readings.

The temperature of the cable during test must be carefully observed and proper corrections made.

TO DETERMINE THE GALVANOMETER CONSTANT.

The tester proceeds to get his galvanometer constant for insulation, as follows:

With connections as shown in figure 186, he depresses the battery key on shunt and moves the shunt to 0.0001. His constant is then determined by dividing the resulting deflection by the shunt value and multiplying by one-tenth. This gives the deflection which the battery used would cause through 1 megohm without shunt.

INSULATION TEST.

Connections are then made as shown in figure 187. This connection puts the galvanometer and battery in series, through the shunt and 100,000-ohm box, with the conductor, its insulation throughout its whole length and ground. All the other conductors of the cable should also be connected to ground. The test is therefore against all the other conductors and ground, thus determining the existence of crosses between conductors as well as insulation to ground.

Having connected thus to No. 1 conductor, the shunt is set at 0.001 and the battery button depressed. With rubber cables an electrification of one minute is desirable. In paper cable the electrification is practically instantaneous, and the shunt may be moved to gradually smaller values until a readable deflection is obtained. The deflection, shunt, and conductor number are then entered in a notebook, and if the reading is normal the conductor is replaced in the bunch and the next one is tested.

On short cables where exact readings are impracticable thirty seconds' electrification is sufficient.

Should trouble be found, the assistant should be called and asked to scrape the insulation of the conductor in question carefully and see that it is free. Having identified all wires, it is a simple matter to test the telephone wire by substituting it for one of the wires first tested.

The following example is submitted to indicate the method of calculating the insulation resistance of a cable.

Suppose our deflection through 100,000 ohms, using 0.0001 shunt, to be 80 divisions, then the constant equals 80 divided by 0.0001 and multiplied by one-tenth. Constant equals 80,000.

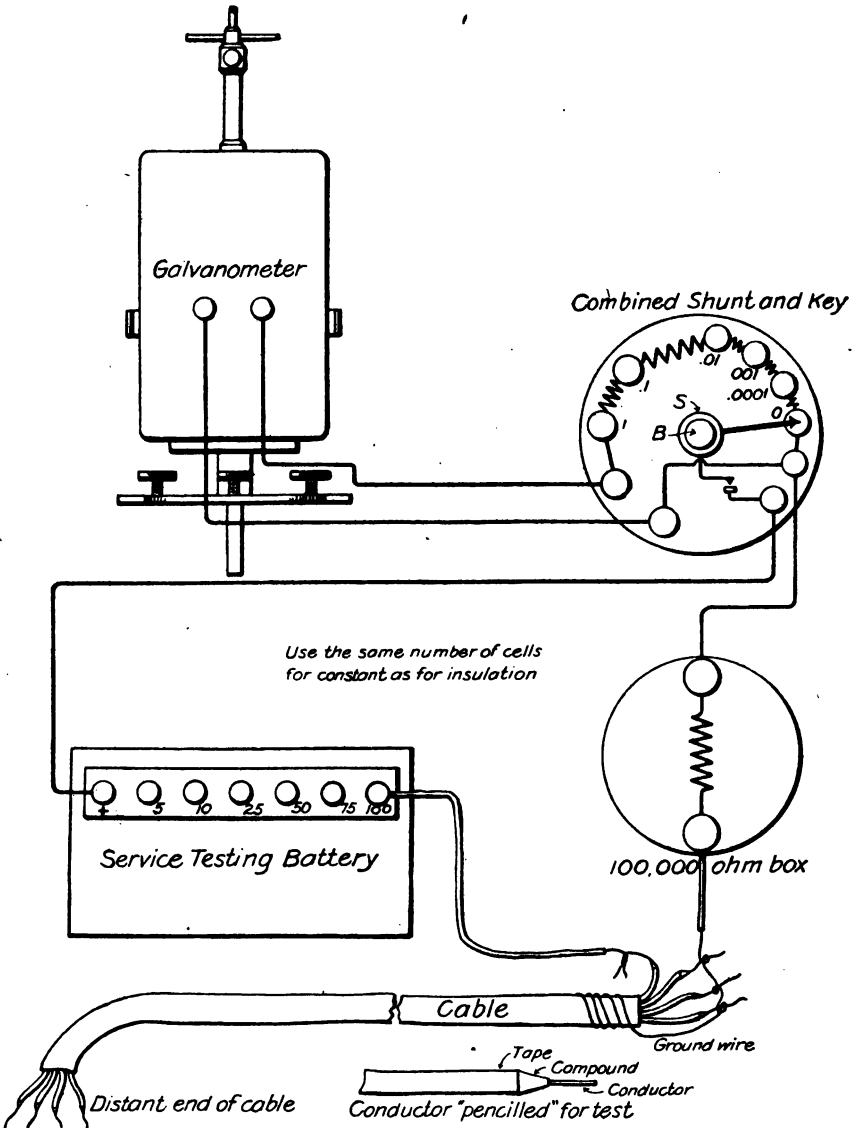

FIG. 187.

Suppose our deflection on conductor No. 1 is 40, with a shunt value of 1; then, since the constant is the deflection through 1 megohm, the number of megohms represented by this deflection will be 80,000 divided by 40, or 2,000 megohms.

If the cable were $1\frac{1}{2}$ miles long, to reduce this value to megohms per mile it would be necessary to multiply it by $1\frac{1}{2}$, and the insulation resistance per mile would be 3,000 megohms, an average value for paper cables under usual weather conditions, not including pot heads.

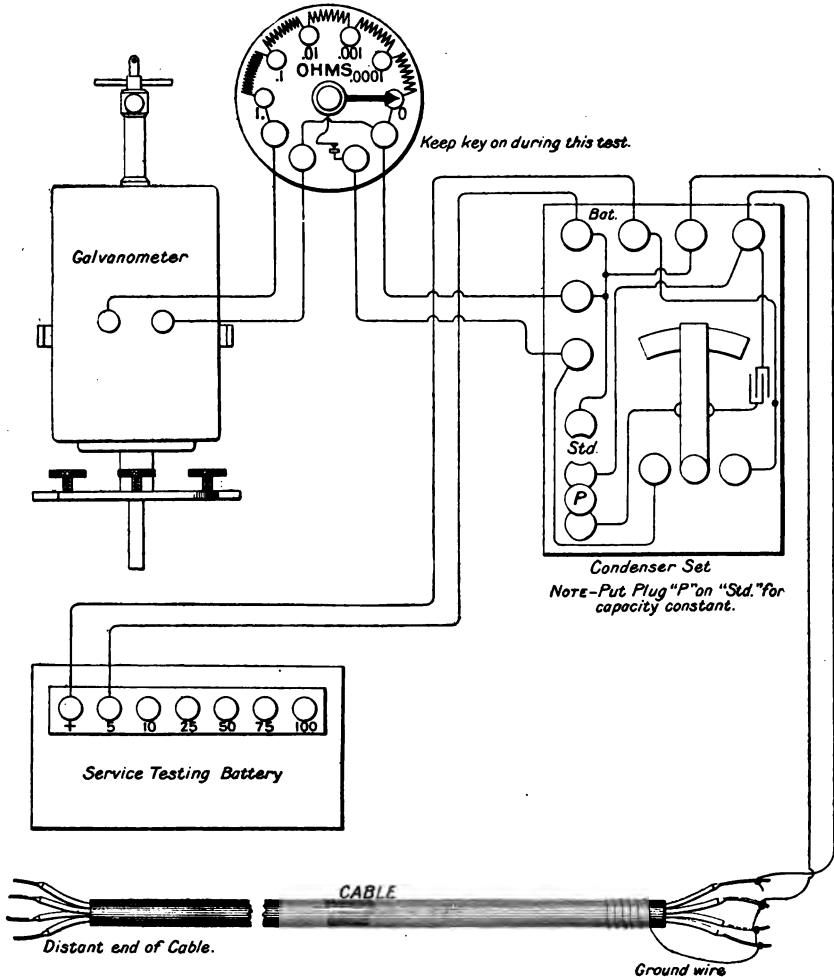

FIG. 188.

CAPACITY TEST.

Having obtained the insulation resistance of all the conductors, the battery is disconnected, the 100,000-ohm box is replaced in the case, and the condenser set is connected as shown in figure 188. The condenser set is held in the hand. Suitable battery (not more than 5 or 10 cells) is connected to the condenser. The deflection on the standard condenser is then compared with the deflection caused by the cable, using the same battery and shunt.

The following example shows the method of calculating capacity: Suppose the deflection through the standard condenser were 150 and the leads were negligible.

Suppose our deflection through the cable were 450.

The capacity of the cable would then be 450 divided by 150, or three times the capacity of standard (one-third). The cable capacity would be, therefore, 1 microfarad.

If the cable were 2 miles long its capacity per mile would be 1 divided by 2, or 0.5 microfarads, a little above the average for rubber cable.

POINTS FOR THE TESTER.

1. Never open a paper cable on a damp, foggy, misty, or rainy day, whether under cover or not.
2. Never pronounce a cable bad until you are satisfied that all ends are absolutely clear and dry.
3. Never test any kind of cable on a damp day if it can be avoided.
4. Where convenient, use the testing battery for insulation and capacity only, thus saving it against possible short circuit or heavy drain.
5. Get thoroughly acquainted with the instruments before starting the test and mark all the adjustments, so that little time need be wasted in setting up.
6. Remember that accurate readings never are possible under moist conditions and everything should be as dry as practicable.
7. Be sure to leave the cable ends thoroughly sealed.
8. Be sure to mark conductor numbers plainly.
9. The micrometer caliper should be used to determine the exact diameter of the conductor and insulation, to aid in future records of the cable.
10. All data concerning the cable should be entered before taking down the instruments, making sure that nothing will be lacking.

OHMMETER, MODEL 1904.

The theoretical diagram of the ohmmeter, model 1904, is given in figure 185, in which the parts of the conventional form of the Wheatstone bridge are apparent. The *A* and *B*, or "balance arms," are the two parts of the bridge wire *W W* into which it is divided by the "toucher."

The two standard resistance coils 10 and 100 ohms, respectively, correspond to the *R* arm of the bridge, *X* (the unknown resistance) forming the other arm. The telephone receiver may take the place of the galvanometer, balance being indicated by the cessation of the clicks and frying sound when the toucher has reached the proper graduation on the bridge wire.

DIRECTIONS FOR USING THE OHMMETER, MODEL 1904.

(See figs. 185, 189, and 190.)

Connect a battery, preferably a couple of dry cells external to the testing set, to posts marked *B A* and the unknown resistance to posts X_1, X_2 . If the resistance is small, insert the plug at 10, and if large at 100. Depress the key and operate catch; then draw the stylus *lightly* across the horizontal scale, touching the convolutions of wire until the galvanometer reverses its deflection.

Multiples of 50 are read on the horizontal scale, and fractions of a turn on the drum at the right. The tabular number corresponding to this number, as found in the table on the lid of the ohmmeter, when multiplied by 10 or 100, depending on whether the plug is at 10 or 100, will give the correct resistance.

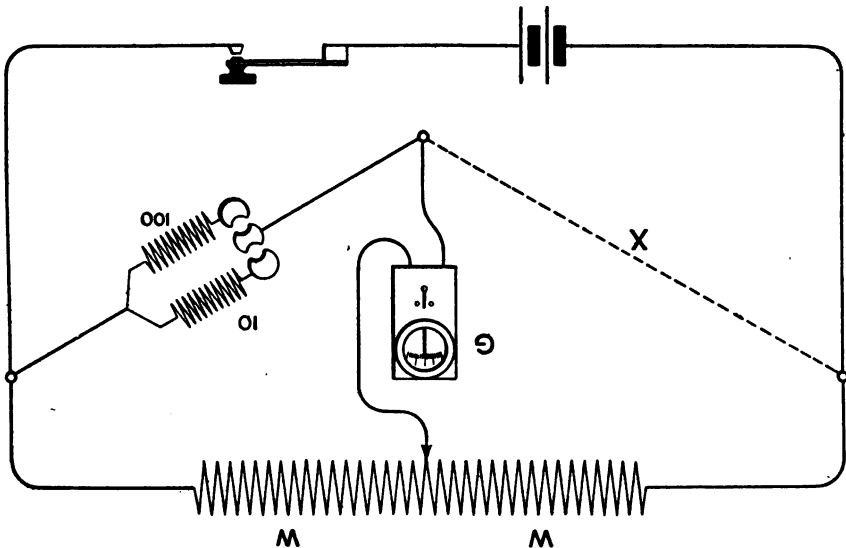

FIG. 189.—Circuit of ohmmeter, model 1904.

For example, if the balance is found between convolutions Nos. 150 and 200 on the horizontal scale and the drum scale reads 46, the exact reading is 196. Referring to the table, the number corresponding to this is 0.2438, and the resistance, if the plug is inserted in 10, will be 2.438 ohms; or, if the plug is inserted in 100, will be 24.38 ohms.

A telephone receiver may be used in place of the galvanometer in the ohmmeter by disconnecting one of the cords from the post marked "*Tel.*" and connecting the receiver to those posts.

The portable galvanometer may be used in the place of the galvanometer in the ohmmeter by proceeding as for the receiver. In this case it would be advisable, however, to make use of the galvanometer with shunt.

The method of measuring conductor resistance of a cable is shown in figure 190. The copper resistance is tested in pairs and should not vary to any great extent (in very large cables the outer layers will be a few per cent higher in resistance than the core). The resistance per stretch is determined by dividing the loop reading by 2. The resistance per mile is determined by dividing the total resistance per stretch by the number of miles in the stretch.

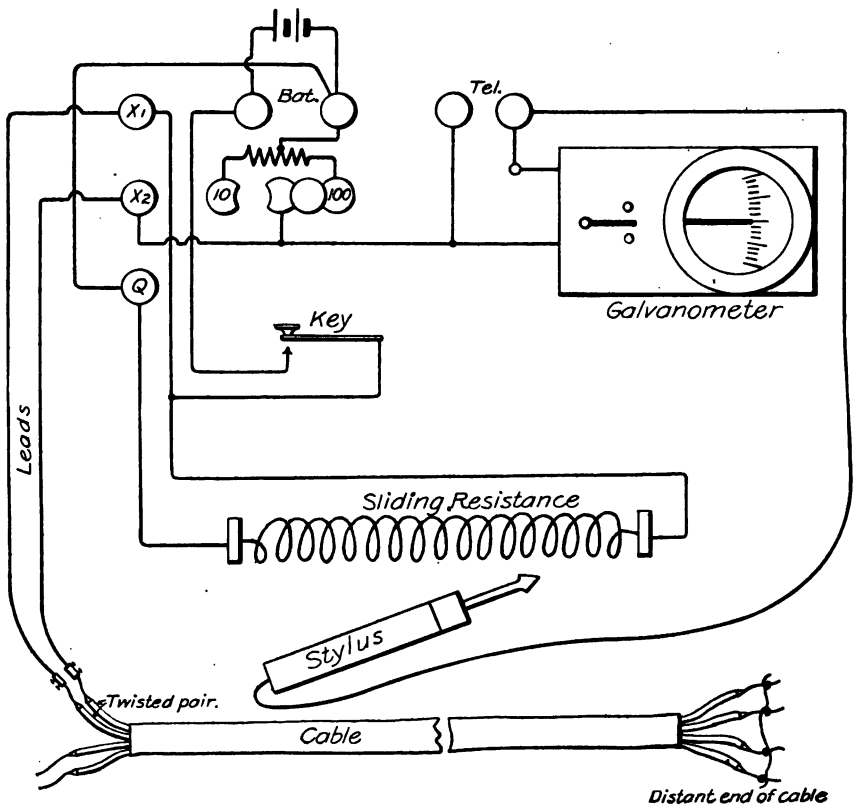

FIG. 190.

VOLTAMMETER FOR INSPECTION AND TESTING OF BATTERIES.

RESISTANCE OF VOLTMETER COIL, 100 OHMS; OF AMMETER COIL, 0.5 OHM.

This is a low-range instrument, designed especially for inspecting telephone and telegraph batteries and storage cells. (See fig. 191.)

Caution.—Never connect with more than one storage cell or more than three of other kinds. Too large a current or high voltage will bend the indicator or burn out the coils.

Dry batteries and sal ammoniac batteries (such as Leclanche, Gonda, etc.) should have voltages between 1.4 and 1.5. This is obtained by connecting with binding posts *V P—P* being positive.

Then, by connecting with A instead of V , the current is indicated on the ampere scale. Since the resistance of the ampere coils is 0.5 ohm, the internal resistance of the cell is given by the formula $\frac{E-0.5 C}{C}$ where E =voltage of the cell and C =current in amperes. The deterioration of a dry or sal ammoniac battery is shown by a fall in voltage much below 1.4 and a rise in its internal resistance. This latter should not exceed a few ohms.

METHOD OF LOCATING FAULTS IN MULTIPLE CONDUCTOR CABLES WITH MODEL 1904 OHMMETER.

Arrange to have the distant end of the faulty conductor connected to a sound conductor in the same cable. Attach the faulty conductor to post X_1 on the ohmmeter and the sound conductor to post Q . See that the variable plug is not inserted at either 10 or 100. Attach a ground wire to X_2 . Find a balance as in testing for copper resistance. If the reading, in scale parts, is A and the length of the cable, in feet, is L , the distance to the fault will be L multiplied by $2A$ divided by 1,000. These values hold for any sized cable, but assume that the conductors used are of the same gauge. The connections are shown in figure 192.

The following example will indicate the method of making this test:

Suppose connections have been made as above and the stylus is at 150 on the scale when a balance has been obtained. Suppose the cable to be 6,000 feet long; 6,000 multiplied by 300 will equal 1,800,000, which divided by 1,000 equals 1,800 feet. the distance from the observer to the fault.

LOCATION OF A CROSS BY MEANS OF THE VOLTMETER.

In general, the resistance of the wire to the cross and through the point of contact (the cross) of the two wires is small compared with the resistance of the voltmeter itself. The following method depends upon the approximate correctness of this assumption. The connections are shown in figure 193.

One of the wires is grounded at some station E beyond the cross, the other being opened there. The line battery being connected up through a known resistance, R (a 150-ohm relay, for instance), as



Fig. 191.

shown, readings are taken of the voltmeter V connected as shown first by the full lines and second as shown by dotted lines.

Calling the first reading V^1 and the second V^2 and R 150 ohms, the resistance of the wire X to the cross is given by the formula $X = \frac{V^1}{V^2} \times R$; and if the resistance of the wire per mile is A ohms, the number of miles to the cross is given by $\frac{X}{A}$.

The quick readings that can be made with the voltmeter make this a useful method of locating swinging crosses.

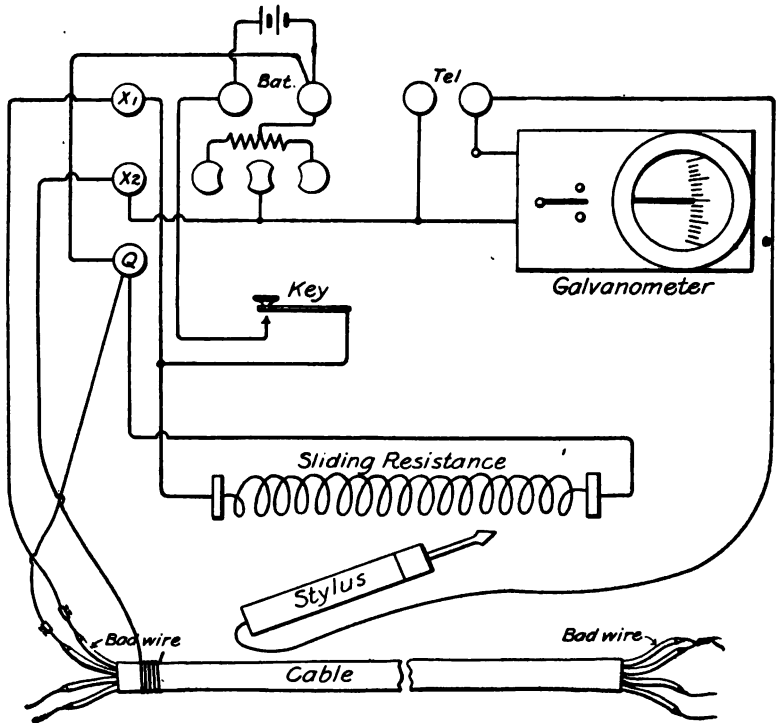

FIG. 192.

The importance in all these tests, excepting ohmmeter, model 1904, of having some standard known resistances available is apparent. Spare relays and sounders, if not already measured up accurately, should be so measured up and marked at the first opportunity or request made for such standardized coils. So-called 150-ohm relays and 4-ohm sounders frequently vary 5 per cent from their stated resistance and would make considerable error in the calculated positions of faults if used as standards.

EXPLORING COIL.

It is oftentimes necessary to locate a ground or cross in cables installed in trenches or underground conduit where standard instruments are not available. The use of an exploring coil in such cases may avoid the necessity for taking up considerable lengths of cable and opening unnecessary test points.

The exploring coil may be made as follows: Take a 1-inch thick pine board of rectangular shape, 1 foot by 2 feet, and wind around its outer edge as many turns of insulated wire as convenient. This wire may be cotton-covered magnet wire, No. 18 gauge, or smaller. In place of this board a rectangular frame, with channel cross section, may be made. To use the exploring coil, a source of alternating or pulsating current is applied to the grounded conductor. This source may be from a buzzer and induction coil connected to a battery of

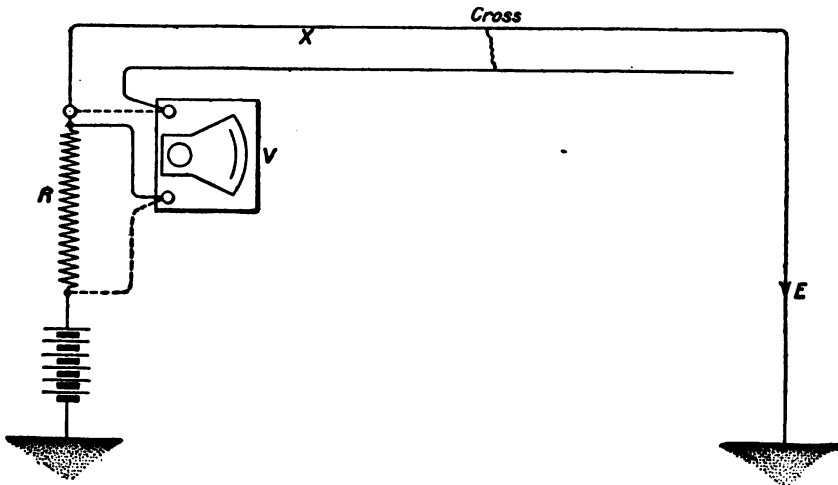

FIG. 193.

dry cells, a 30-volt telephone storage battery, or a 110-volt power circuit. The exploring coil, with terminals connected to a telephone receiver, is now carried along the route of the cable, being held as near the ground as possible with the plane of the coil parallel with the cable and the long side of the coil next to the ground. The buzzer should be heard in the telephone receiver until the grounded point in the cable has been passed, when the sound should cease entirely or become much weaker. The exploring coil may also be used for identifying cables where a number of them are laid in a common trench. A variable current is sent through the cable to be identified and is picked up by the exploring coil, one side of which should be held close to or parallel with the cable. The short end of the coil may be used for this purpose.

MURRAY AND VARLEY LOOP TESTS.

The preceding sections of this chapter have described certain methods of testing, entirely qualitative in character, as well as standard methods for measuring conductor resistance, electrostatic capacity, and insulation resistance. In addition to these there are certain quantitative measurements necessary for the location of faults in conductors, which will now be briefly described.

These tests for fault location consist essentially of cases of the application of the simple methods of measurements previously described, requiring special connections and a certain amount of computation from observations. It should be especially noted, however, that the methods of fault location commonly used do not necessitate special and complicated apparatus, but rather the application of

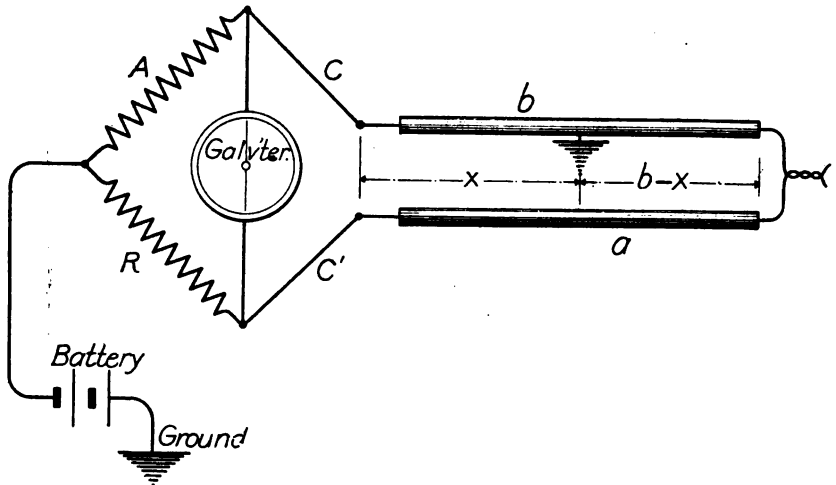

FIG. 194.

simple methods to special circuits and the solution of elementary formulæ. Two tests most generally used and of wide application are the Murray loop test and the Varley loop test. The Murray loop test is the more easily made, but is of less general application than the Varley.

The Murray loop circuit is shown in figure 194, in which A is one of the arms of a Wheatstone bridge and R the adjustable resistance. G is a galvanometer or other current indicator, $C C'$ the leads from bridge to conductors under test, b the faulty wire, a a good wire of the same length and resistance. The resistance of the faulty conductor, from the point of test to the fault is denoted as x ; a and b are connected at distant end as shown, the leads $C C'$ should be carefully measured, if their length and resistance are not negligible

as compared with those of the wires a and b and the values recorded for use in correcting readings. When the resistance R is so adjusted that the galvanometer is not deflected the distance to the fault is—

$$x = \frac{A L}{A + R}$$

where L is the combined length of a and b . The above formula assumes that the leads are negligible. If such is not the case the formula becomes—

$$x = \frac{A(L + C C')}{A + R} - C.$$

It will usually be practicable to make the leads negligible or at least to have $C = C'$. It is to be noted particularly that this method assumes that the good and bad wires are of equal resistance. It is

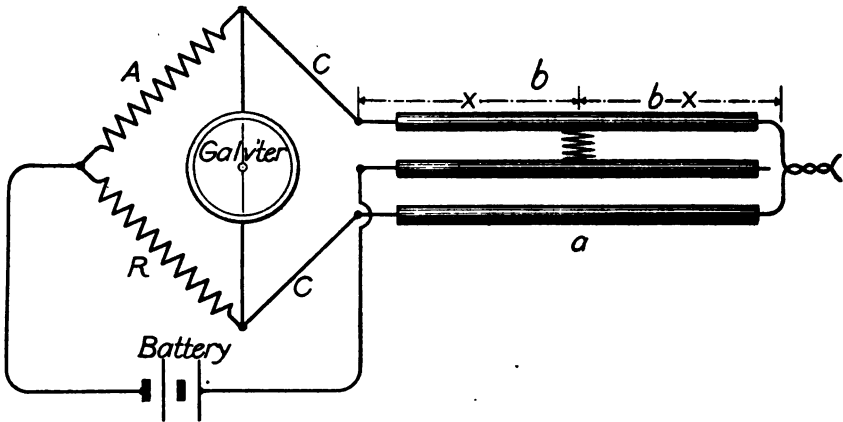

FIG. 195.

advisable in each case to check the fault location obtained by the above circuit by reversing the wires a and b and making a second location. In the above formula A and R are in ohms, all other quantities in units of length.

For locating crossed wires the circuit of figure 195 should be used. It will be noted that the connections are the same as for locating grounds, except that the battery is connected to one of the pair of crossed wires.

The Varley loop test, while not so simple and quickly made as the Murray test described above, is of more general application and can be made in situations where the Murray test can not. The connections for this test are shown in figure 196. The various parts of the circuit are given the same letter designations as for the Murray test of figures 194 and 195.

With the circuit of figure 196 adjust the variable resistance arm R of the Wheatstone bridge until the galvanometer is not deflected, record the values of A , B , and R . Now disconnect the ground from battery and connect as shown by dotted line and measure the combined resistance of the leads $C C'$ and the two conductors $a b$ in series; call this value r . Combining the results of the two measurements taken above, the resistance of the conductor from the point of test to the fault is—

$$x = \frac{Br - AR}{A + B} - C.$$

Check the measurements and calculations obtained by the above process by reversing the connections of the bridge to the conductors at either end of the leads and obtain a second set of readings. If the

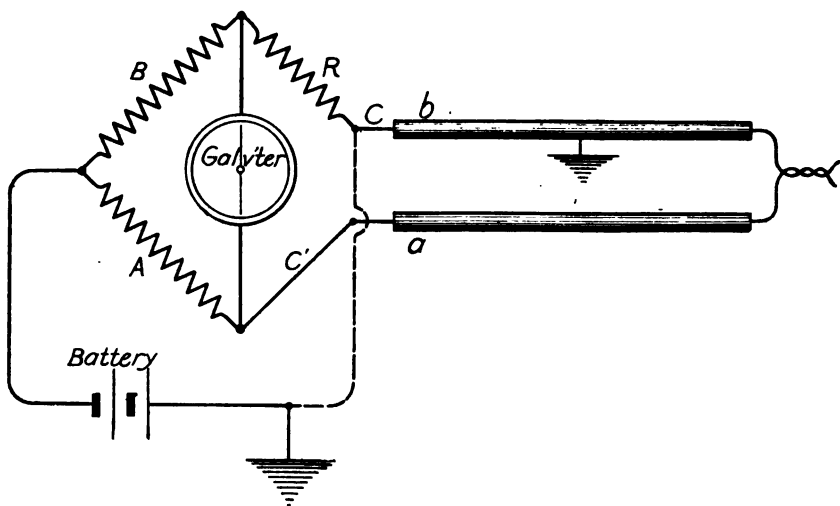

FIG. 196.

new values of bridge readings be designated as A' , B' , and R' , the new value of the resistance to the fault is—

$$x = \frac{A'(r + B')}{A' + B'} - C.$$

If C equal the total resistance of the bad wire the distance to the fault is $\frac{a}{C}L$, where L is the total length of the wire. The check measurements should always be made when using either the Varley or the Murray loop test, as the time and labor required are considerable and the certainty of location is much increased.

For crossed wires the method of figure 197a should be used. The circuit, it will be noted, is the same as on figure 196, except that one wire of the crossed pair is used to replace the earth connection.

LOCATION OF FAULTS IN TELEGRAPH LINES.

In order to secure the best possible result in the working of telegraph lines we must keep down the resistance of the conductor in the circuit and increase the resistance of the insulator to the greatest possible extent. In other words, the resistance must be as small as possible in the route we wish the electric current to travel and as great as possible in every other direction. The practical working value of a telegraph line is the margin between the joint resistance of the conductor and the insulator, and that of the insulation alone. The tension of the retracting spring of the relay armature when upon a "working adjustment" is the measure of this margin or difference. It is evident that this margin may be increased in two ways, viz: (1) By increasing the insulation resistance; (2) by decreasing the resistance of the conductor.—Pope's Modern Practice of Electric Telegraph.

Faults causing departure from normal working conditions are due to partial or complete contacts of the line wire, directly or indirectly with the ground, usually called by telegraphers "escapes" and

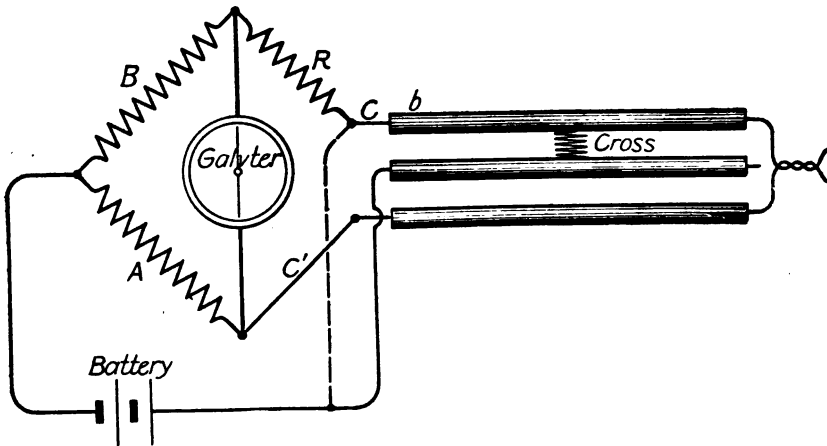

FIG. 197a.

"grounds;" crosses, caused by two or more wires coming together; and partial or complete disconnections, causing abnormally high resistance, or complete interruption.

"Escapes" mean imperfect insulation, due to defective insulators, contact of foliage with the wire, or defective office wiring. "Grounds" are often brought about by the wire being down on the ground, to its being detached from an insulator and lying against an iron pole, or defective office wiring.

Abnormally high resistance is due to defective and corroded joints in the line wire or to bad connections in the office wiring, instruments, batteries, or grounds.

When stations are not very far apart, especially where they are along a railroad or good road, the location of the fault between two stations by calling up each station in succession is usually sufficient.

In case of escapes it is evident that opening the key beyond the escape will not entirely open the circuit at the testing office where the main-line battery is located. So by opening in succession, beginning at distant stations, until we come to a station where practically all current ceases when the key is opened, will indicate that we have passed the escape.

The inability to work beyond a given station indicates a "dead ground."

Total breaks are located by stations successively grounding, beginning at the nearest office to the testing office.

High resistances due to imperfect connections are located by successive grounding in a similar way, a sudden marked falling off in strength of current indicating that the high resistance has just been passed.

In the case of crosses an intermediate office is asked to open No. 1 of the crossed wires and work on No. 2. If upon opening No. 2 at the testing office the cross remains, as shown by distant stations' sending coming in on No. 1, it is evident that the cross is between the testing office and the intermediate one. If the cross had disappeared upon opening No. 1 at the intermediate office it is beyond the intermediate office.

In the first case the office next nearest the testing office is called and the test repeated there. In the second case we should proceed outward from the intermediate office. A metallic cross may be distinguished from a leakage or "weather cross" by the sending through the cross in the first case coming nearly as strong as it does on its own wire.

If a high resistance fault is due to bad office connection it can be detected by cutting out the offices in succession until an evident improvement is noted in working. If due to bad joints in the line it can generally be detected by grounding at each station in succession; but these can best be located by measurements of resistances from point to point.

Faulty ground plates often introduce very large resistance in the line. Connections with these should be very carefully made. Only soldered joints should be permitted, if possible, and a good-sized rod, plate, or a good length of coiled wire buried in thoroughly damp ground should be used. It has often been found that the resistance of the ground connection was as much as all the rest of the circuit.

Two lines connected with a bad ground plate will behave as if crossed.

Intermittent or swinging escapes, grounds, and crosses are exceedingly troublesome to locate. They often require accurate and prompt measurements. The Weston voltmeter and millimeter set described, being capable of almost instantaneous readings, is particularly useful

in this kind of measurement. The ohmmeter measures resistances directly and almost as quickly. The Wheatstone bridge gives the most accurate results, but considerable skill and experience are necessary in its use.

The ohmmeter and meter set will, it is believed, give greatest satisfaction in ordinary office measurements of resistance. The meter has the additional advantage of giving means for measurements of voltage and current as well.

The ohmmeter furnishes not only a ready means of measuring resistance, but lends itself to loop tests as well. Its application in locating crosses and grounds, especially of the troublesome "swinging" variety, when the line consists of two or more wires, is given below.

Suppose an escape comes on No. 2. The distant station is asked to join, but not ground, Nos. 1 and 2. Suppose, now, balance is obtained at 170, corresponding to No. 2.

Then $170 \times .227 = 38.6$ miles, distance to escape.

Where more than two wires are in a line, systematic measurements of them in pairs should be taken from time to time with the ohmmeter, when wires are in good condition, and the results recorded for reference when faults occur.

The multipliers of No. 1 with No. 3 and No. 2 with No. 3, and so on, should also be taken and recorded. With this data, in case of a cross, swinging, or otherwise, we loop the remaining good wire with one of the faulty ones at the distant station, ground the other faulty one at one or both ends, and proceed to locate the cross as we did to locate the escape or ground, as just explained, as the cross is now simply an escape in the wires looped together.

In the last methods named, by inserting a relay or other known resistance between the ohmmeter bridge wire and a line wire we may find the resistance of the line up to the fault instead of working it directly in miles.

This would be useful in case we are compelled to measure through some intermediate station, the resistance of its relay being, of course, known.

When the line consists of two or more wires on one of which there is an escape or ground, a good wire is joined (not grounded) with the bad one at the distant station. The scale numbers at balance are recorded. The resistance (relay) is then inserted in circuit with the good wire, as just explained, and another balance made. These two sets of numbers and the resistance of the relay will then give the resistance to the fault.

Where only one wire connects the stations, grounds or escapes may be approximately located by the ammeter or voltmeter as stated on pages 273 and 274. This can be done only by keeping daily record of

line conditions and judging by the local departures therefrom where the faults are.

No very satisfactory simple methods exist for locating escapes when only the faulty wire is available, and the tests can be made at one end only.

The simplest one is the Blavier test. This consists of making measurements of resistance, first with the distant end grounded and next with the distant end open. The resistance of the entire line, when in good condition, must be known. (See fig. 197b).

Suppose measurements are made from *A*, *B* is asked to open, and measurement is made from *A* through wire to fault and through fault. Call the resistance *M* ohms. *B* then closes and another measurement is made. Call this *N* ohms. If the resistance of the

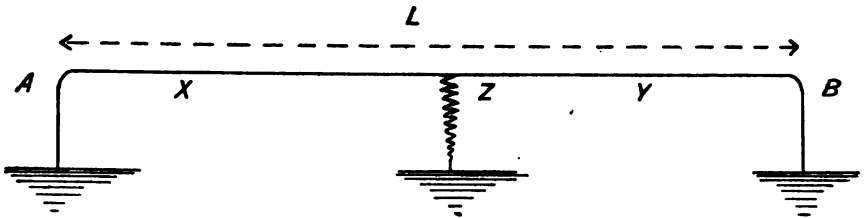

FIG. 197b.

line is *L* when in good condition, the resistance in ohms *X* to the fault will then be given by the formula:

$$X = N - \sqrt{(L - N)(M - N)}.$$

A number of pairs of readings, using each end of the battery, if possible, should be made, and the mean of those pairs that agree most nearly should be taken.

The ohmmeter or Weston set may be used to advantage in these measurements and readings obtained as quickly as possible when the battery current is thrown on, as the resistance may vary rapidly, due to the polarization at the fault. It is an advantage to have the current through the escape *Z* the same when measuring *M* and *N*. As a rough compensation in land line measurement, use double the battery in measuring *N* as when *M* is measured.

CHAPTER IX.

LINES OF INFORMATION.

This general term has been adopted to apply to the means by which military messages are transmitted between two or more stations.

Under modern conditions lines of information are nearly always operated electrically. On account of its certainty, secrecy, and speed, telegraphy over wire lines is to-day without a rival for use on military as well as commercial lines.

As an army advances into hostile territory, it will utilize, as far as possible, existing commercial lines, to connect it with its base. If lines must be constructed for this purpose, they will generally at first consist of insulated wires laid on the ground. If these lines will be needed for some time after the army has advanced, the wires will be put up on light lance poles, thereby transforming them into lines of a more permanent nature. If the lines are to be used for considerable length of time, they will be replaced by ordinary permanent telegraph or telephone lines.

As an army advances into conquered territory it will utilize as far as possible existing commercial lines to connect it with its base. If lines are constructed, they will generally at first consist of the insulated wires laid on the ground which follow the advance. Such of these as are needed will subsequently be put up as light lines on lances, afterward to be converted into permanent pole lines where necessary. Lines of a temporary character will be constructed or laid connecting the camps. When the army goes into action, an important series of lines are required connecting the commanding general, the corps, division, and brigade commanders, the artillery, and probably important points of observation and control at other places on the line.

Classified as to their construction, lines of information are permanent, semipermanent, or field lines.

Permanent lines are those similar in construction to the standard telegraph lines, and usually consist of heavy, bare copper or galvanized iron wire. No. 9 galvanized wire is the standard in our service. These wires are supported on substantial insulators and strong poles. Such lines are generally operated with the standard relays and sounders familiar in commercial offices.

Semipermanent lines consist of lighter bare wires, usually No. 14 galvanized, supported on lighter poles called lances, or on light

tubular iron poles. These lances are fitted with hard rubber or composition insulators. Lines such as these were formerly the standard military construction, and telegraph trains, consisting of wire wagons, battery wagons, and lance trucks, could construct from 7 to 15 miles of these lines a day, depending on conditions. These lines were generally operated with box relays, but in modern use the telephone would frequently be the instrument employed.

Field lines are those laid hastily for temporary use, and usually consist of insulated wire paid out from reels on carts or wagons or in the smaller size wire from hand reels. Sometimes bare wire is used, in which case only the "buzzer" will operate satisfactorily over them. This buzzer is generally used on all field lines, although the field induction telegraph kit may be substituted for it under many conditions.

Classified in regard to their use, lines of information may be considered as either strategical or tactical lines.

Strategical lines are usually of the permanent or semipermanent character, and may be part of the commercial system of the country. They are "base lines" in general, as they lie behind the advancing army and maintain communication with the base and thence to the seat of government. On account of their importance they would frequently be duplicated, and in general over different routes, to insure communication under all conditions. They would in some cases include important submarine cables or even large wireless stations.

Tactical lines are generally of the field line class and are rapidly laid or taken up to follow the movements of the units they connect. Their name indicates their uses. They are the "combat lines" which late improvements in wire, transportation, and instruments have made possible.

FIELD TRANSPORTATION.

In addition to wagons and packs for ordinary transportation, the Signal Corps has found it necessary to devise some special vehicles for transporting and laying wire and carrying such equipment as wireless sets, lances, etc.

The most important of these is the pintle type wagon and the wire cart from which wire may be paid out at a gallop and reeled up almost as speedily. Figure 198 shows a signal corps pintle type wagon, model 1910. In the latest model, the front element of the vehicle carries the reel and wire, and is known as the reel cart. The rear element, known as the signal cart, is a chest of compartments suitable for carrying the buzzers, batteries, flags, field glasses, and other equipment used by field companies of the Signal Corps. The rear signal cart may be detached from the reel cart, and the former used alone in laying and recovering wire. The pintle type wagon is

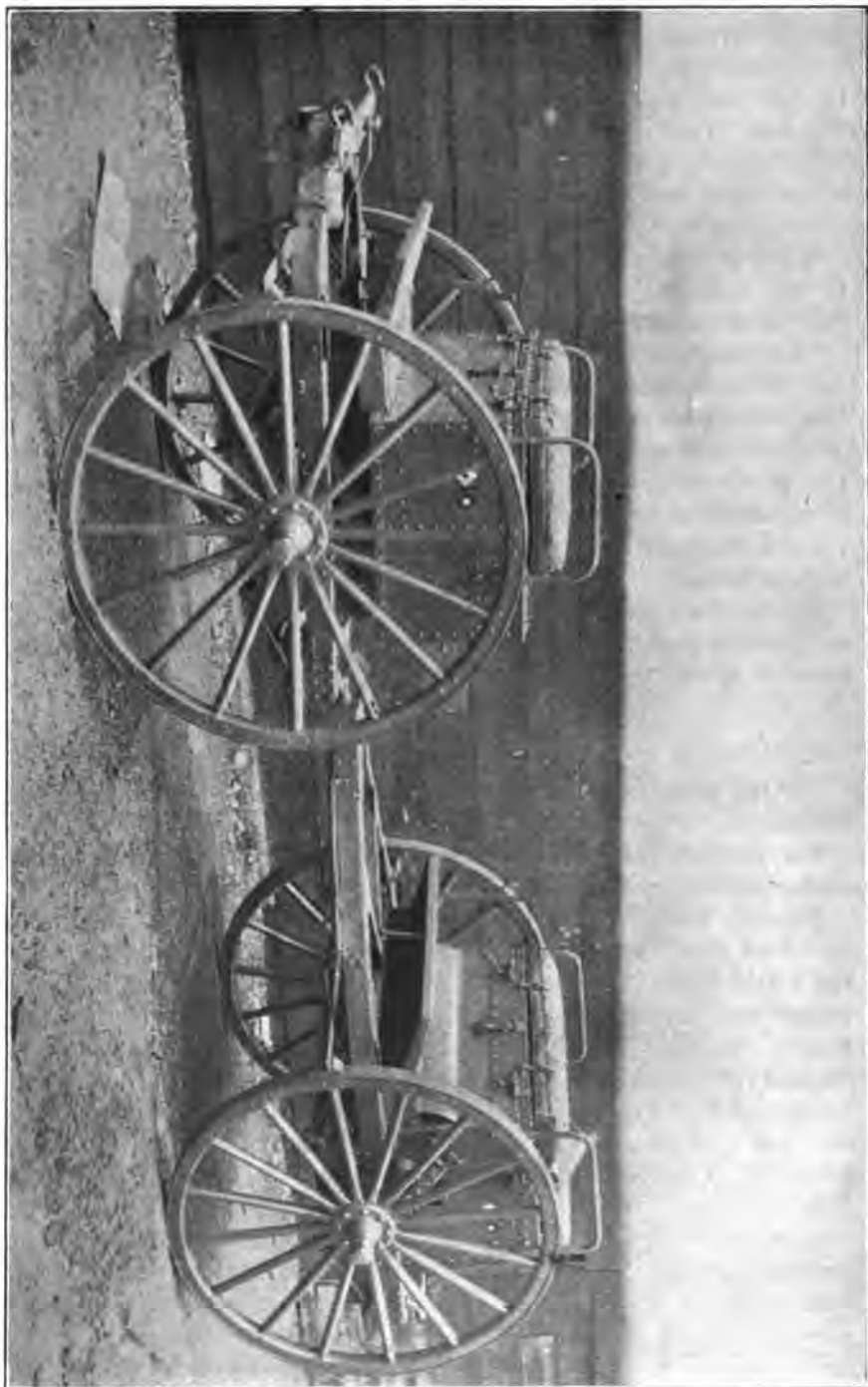

FIG. 198.—Pintle type wire wagon, model 1910.

drawn by four horses. The signal cart chest is capable of being moved forward and backward to adjust weight on the horses' necks.

In case neither of these vehicles are available, field wire lines may be laid and recovered by means of escort wagons and ordinary "barrow" reels.

For handling the small insulated buzzer wire, which is furnished one one-half mile spools, the pay-out handles and breast reels answer every purpose either on foot or mounted.

The instrument wagons are spring wagons provided with paulins or wagon sheets, in which instruments, light tools, repair parts, etc., may be transported.

The lance truck is a wagon with a high seat and long reach, suited for the transportation of lances 18 feet long. Four mules suffice for this load under ordinary conditions.

The balloon train requires two special wagons; one for transportation of the steel cylinders, about 7 feet long and 10 inches diameter, in which the compressed hydrogen gas is carried, and another called a winch wagon, with engine and drum for paying out and recovering captive balloons.

Special pack chests are provided for the Signal Corps supplies, and the present field wireless pack set, which is carried on three mules, requires special fittings for the aparejos.

WIRE USED IN FIELD OPERATIONS.

For the permanent military lines, No. 9 galvanized wire, weighing 320 pounds to the mile, is the standard.

For semipermanent lines, such as lance lines, No. 14 galvanized wire, weighing about 100 pounds per mile, is used.

The two kinds of wire used in field lines are known, respectively, as "field wire" and "buzzer wire." The former corresponds with the "field cable" used abroad. Our field wire consists of a larger copper wire surrounded by ten small tinned steel wires of very high tensile strength. This is covered with a layer of cotton, then vulcanized rubber, and an outer coating of braid, which is saturated with an asphaltum compound. The whole is about one-eighth inch in diameter, has a tensile strength of over 300 pounds, and weighs 70 pounds per mile. Ten miles of it may be carried on the drum of the latest type reel cart. Its strength and insulation are little impaired by wagons and troops passing over it. It is very pliable and lies flat on irregular ground. As it is laid, mounted men follow the reel cart with pikes or lances having hooks on the ends, either placing the wire out of the way on the road or, if need be, hooking it up on trees. It is difficult to break or injure this wire unintentionally. If found broken, instructions have recently been issued to the army

showing the proper method of quick repair. This is done by tying the ends together with a hard knot, leaving about a foot of each free. The insulation is then removed from the ends for several inches and the bare wires twisted together.

Buzzers or field telephones may be quickly connected to field wire by means of "Type A buzzer connectors." These connectors are furnished with sharp teeth that pierce the insulation readily, and when withdrawn damage the wire very little.

In every way this type of wire seems eminently suited for field lines, the only objection being its cost, which is about \$75 per mile.

A small wire of this class, suitable for laying from a hand reel, is called "buzzer wire." This consists of two fine steel wires and one of copper, covered with cotton saturated with compound. This wire weighs about 10 pounds per mile and is put up on half-mile spools. This permits paying out the wire from a simple holder from horseback and its recovery by means of a breast reel. This wire is used for short lines or for emergency lines over rough ground where the heavier field wire can not be carried.

It may be useful to remember that since buzzers will operate over long stretches of bare wire laid on the ground even in wet weather, field lines of any kind of wire available may be laid in emergencies.

INSTRUMENTS FOR ELECTRICAL LINES OF INFORMATION.

Base lines and other permanent telegraph lines will, of course, make use of the familiar commercial apparatus. Morse instruments of various portable forms, such as the box relay, main-line sounder, or pocket relay, will be used on semipermanent lines wherever practicable. These require, however, large battery equipment and well-insulated lines, and in bad weather the instruments are difficult to keep in adjustment.

THE BUZZER.

On our field lines the buzzer in one of its forms is almost universally used. This instrument was introduced into our service about 1890 and first showed its capabilities in the Philippine and China campaigns. In its present forms of "field buzzer," and still more portable "cavalry buzzer," it combines in a small leather case weighing a few pounds a complete telegraph and telephone station, including the necessary batteries. Its capacity for working over circuits impossible for any other telegraph instrument, such as bare-wire lines laid on the ground, through wire of wire fences, or railroad rails, or, more incredible still, through considerable breaks in the line when the ends lie on the ground, makes it the ideal instrument for field lines.

To open a station it is necessary only to fasten the buzzer connector with flexible cord from one binding post to the field wire, and from the other binding post a flexible wire leads to a small ground rod or metal peg driven into the ground. In emergencies the ground wire may be held in the hand, or when used mounted may be connected to the horse by a small metal plate under the saddle blanket.

By working the key an interrupter is operated giving a high singing note, which is broken up into the dots and dashes of the Morse alphabet. These correspond to vibratory electrical impulses which go out on the line and are heard in the telephone receiver at the distant station. The efficiency of the buzzer under the difficult conditions stated is due to the marvelous sensitiveness of the telephone receiver to these rapidly pulsating currents. In practically the same circuit as the interrupter is a telephone transmitter, and when the button switch on this is depressed the instrument becomes at once converted into a very efficient telephone set.

The cavalry buzzer is the lightest, weighing about $4\frac{1}{2}$ pounds, and comparable to a good-sized field glass in dimensions. It has not so much power as the field buzzer, which is about 50 per cent heavier and bulkier. For buzzer telegraphy over difficult lines the field buzzer's superior power will probably make it the preferable instrument.

THE FIELD TELEPHONE.

This instrument, as described in Chapter V, has all the power of the most complete telephone. The box is very strong and weather-proof and has a strap for convenience in carrying. The transmitter and receiver are attached to a handle containing a switch, which is depressed by the fingers and brings the battery into operation when talking. The connections are very simple and easily repaired when deranged. It can be connected to field lines and the ground in the same way as the buzzer. Its commonest use, however, is for camp lines where, with its generator and call bell, it is specially suited for connection with the field switchboard. This latter instrument has ten drops and can take care of connections with 10 lines, or more telephones if party lines are practicable. This switchboard uses cams for making connections, instead of the cords and plugs of the commercial switchboards, thus saving greatly in bulk and securing greater portability.

FIELD INDUCTION TELEGRAPH.

On semipermanent lines, especially where business over them is heavy, the continual use of the buzzer is very fatiguing to Morse operators. The field induction telegraph set, permitting the use of the ordinary sounder, has been devised especially for this class of

lines. The case, furnished with a carrying strap, weighs about 12 pounds. In this are a polarized relay, sounder, key, four cells of dry battery, and a special form of induction coil. By means of this induction coil the operation of the key sends out impulses of high voltage over the line and relays. These relays are very sensitive and operate with a remarkably small current. As a result of the voltage increase and relay sensibility, three of the dry cells will work the sets over hundreds of miles of iron wire, over ordinary circuits where the insulation leakage permits the escape of 95 per cent of the current. Doing away as it does with carrying large amounts of battery, it is believed to be a useful intermediate instrument between the buzzer and the regular telegraph installation. (See figs. 204 and 205.)

SELECTION OF INSTRUMENTS.

It thus appears that the buzzer, the telephone, and telegraph each has fairly well defined rôles in operating electrical lines of information. The buzzer is the pioneer which clears the way, follows up the fighting line, and can operate over any kind of a line. Its function as a telegraph instrument is the paramount one on account of its reliability, although as stated it is a good telephone when the wire is in proper condition. The field telephone is most useful in camp administration lines or over semipermanent lines in general, where telephone service seems desirable.

The telegraph is standard where lines are established and where the volume and importance of business become great. To the trained operator there is nothing to equal the clearness and certainty with which a message on a Morse sounder is delivered, and such operation is the ultimate excellence toward which military lines aim.

The decision as to when the telephone or telegraph should be installed or used is governed by the following considerations:

The telephone does not require trained operators.

The telephone may be used for direct, and consequently confidential, communication between officers.

Time is saved, compared with telegraphy, especially when the users are accustomed to the telephone.

The telegraph is superior to the telephone in the following ways:

Accuracy.—A written message, spelled out by telegraphy, written and delivered, has an obvious advantage over one delivered by word of mouth.

Reliability.—In the field, especially when the wind is blowing in the ears and various other noises tend to confuse, it is very hard to distinguish in the telephone words which sound alike. This is especially confusing to an enlisted man unused to expressions common in military messages. The sharp signals on the buzzer or sounder are much more reliable.

Speed.—It is found in the case of written messages transmitted by buzzer and telephone, that, owing to frequent repetitions required by telephone, the buzzer will generally exceed it in speed.

From the foregoing considerations, it is evident that officers should, when time permits, always write out their messages in proper form. The use of the telephone should be restricted to communication between officers. The direction to an operator verbally to send messages by telegraph is very inadvisable. Sending messages by dictation through the telephone invites almost certain errors.

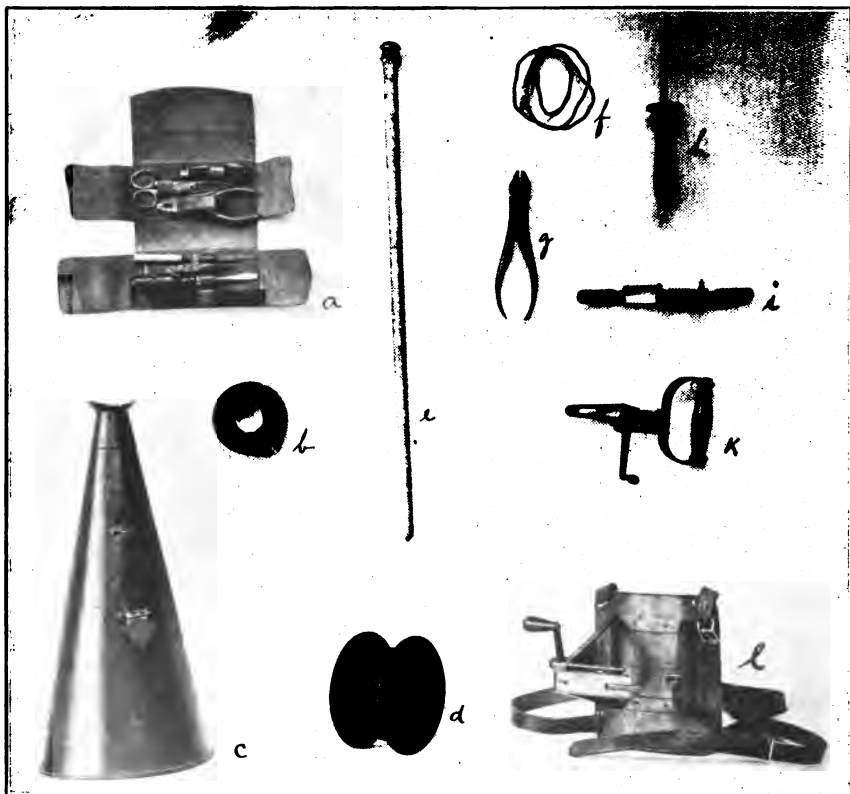

FIG. 199.—Standard articles of field equipment.

- | | |
|---------------------------------|---------------------------------|
| (a) Inspector's pocket kit. | (g) Pliers. |
| (b) Insulating tape. | (h) Pay-out handle. |
| (c) Field megaphone. | (i) Buzzer connector, type "B." |
| (d) Spool buzzer wire. | (k) Hand reel. |
| (e) Telephone ground rod. | (l) Breast reel. |
| (f) Buzzer connector, type "A." | |

MISCELLANEOUS FIELD EQUIPMENT.

Breast reels.—Breast reels, fig. 199 (l), are used for taking up considerable lengths of buzzer wire. These reels have a gear of $2\frac{1}{2}$ to 1. They are made of brass with black finish and weigh about one-half pound. These reels are not used for paying out buzzer wire.

Hand reels.—Hand reels, fig. 199 (*k*), are used in taking up short lengths of buzzer wire. They are made of brass with oak handles. The hand reel is also used in paying out buzzer wire.

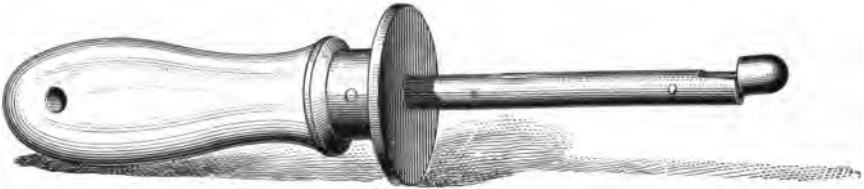

FIG. 200.—Signal Corps pay-out handle.

Payout handles.—A payout handle (fig. 200) consists of a brass rod 4 inches in length with a wooden handle on one end. They are used in paying out buzzer wire, the spool being held on the rod by a spring joint.

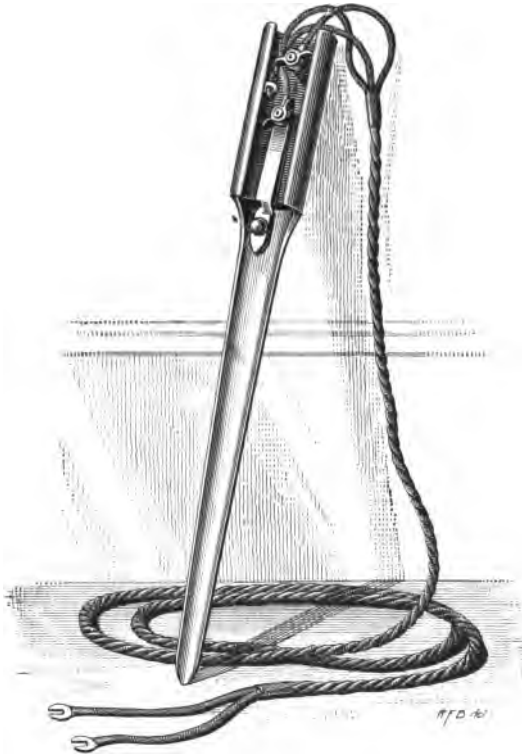

FIG. 201.—Ground rod, model 1910.

Ground rods.—Two types of ground rods are used for field work. One type consists of the ordinary telephone ground rod, shown in figure 199*e*. The ground rod, model 1910, shown in figure 201, is 16½ inches in length, and weighs about three-fourths of a pound. It is



made of steel tubing with a block of insulating material mounted in the handle. Upon this handle is mounted a test clamp terminating in the binding post. The body of the rod is connected to a similar binding post $1\frac{1}{2}$ inches above the clamp binding post. These ground rods are used in connecting telephones and buzzers to field-wire lines. To connect the line the rod is inserted in the earth near the wire, and the field wire "clipped" on the test clamp. One end of the double flexible cord is connected to the binding posts mentioned and the other end to the telephone or buzzer binding posts.

Pikes, wire.—The wire pike with model 1910 hook is shown in figure 202. This hook is made of malleable cast iron. The upper point is bent out three-fourths inch to facilitate picking up wire by mounted men. The hook proper is about one-half foot in length and is carried on a staff of straight-grained hickory. The complete pike is 9 feet in length.

Megaphones, fiber, 18-inch.—The latest type of Signal Corps field megaphone is made of fiber, with aluminum mouthpiece and leather handle. These megaphones are 18 inches long and 9 inches at the diameter of the bell. Fig. 199 (c).

Poles, lance, and insulators.—These poles are usually made of well-seasoned, straight-grained pine or cypress, and are 13 feet 11 inches from tip to tip. The diameter of the pole at the butt is 2 inches, tapering to $1\frac{1}{2}$ inches where it enters the head. The butt of each pole is provided with a blunt point 3 inches long. The top is shaped to fit in

FIG. 202.—Wire pike.

a galvanized-iron head 3 inches in length. The latter is threaded to receive a correspondingly threaded galvanized-iron rod, upon which is fitted a molded mica insulator. Two different devices are used for holding the wire upon the insulators. The first is a bent galvanized-iron wire appliance called from its shape a "pig-tail insulator." The second is a U-shaped device similarly mounted, called a "clamp insulator." The clamp insulator is employed on about every fifth pole of a lance line, to prevent a longitudinal movement of the wire, while the pig-tail insulator is used upon the other poles. The lance pole weighs about 7 pounds and the galvanized-iron head with insulator about 3 pounds.

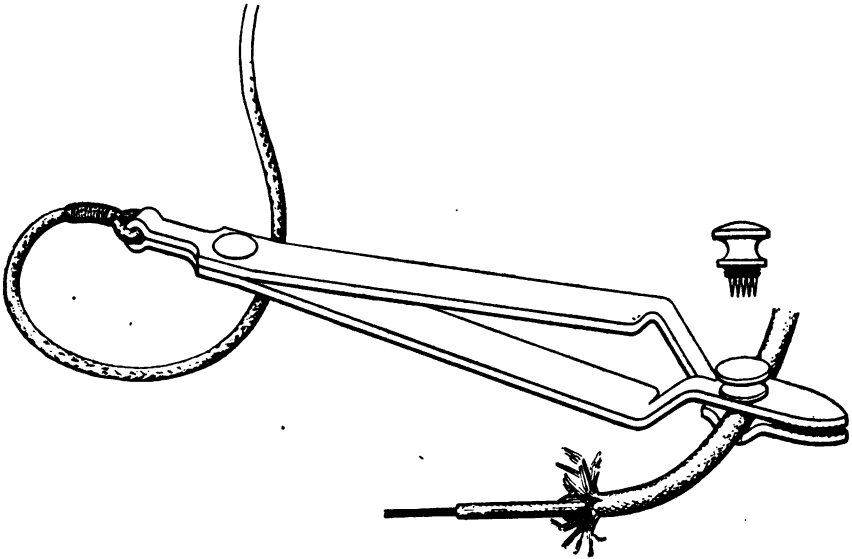

FIG. 203.—Buzzer connector, type "A."

Buzzer connectors.—*Model A:* This form of connector is made of nicked steel, and should be used for "clipping" on the buzzer wire and the 11-strand field wire. Extra studs should be kept on hand for repairs. These studs screw into the connector and may be removed if necessary. The flexible cord should not be knotted up or twisted, as this tends to break it. A model *A* connector is shown in figure 203.

Model B: This connector is made of brass, with fiber block and small steel needle teeth for making contact, and is used with the field wire, field artillery type (double conductor). To use, lay the wire in the conductor, clamp it, and connect the telephone cord to the binding post on either side of the connector. A model *B* connector is shown in figure 199 (*i*).

Inspector's pocket kit.—This kit contains the following equipment, fig. 199 (a) :

- 1 combined screw-driver and skinning knife with safety spring.
- 1 electrician's scissors, 5-inch, nickel.
- 1 pair pliers, 5-inch, side cutting, nickel.
- 1 bastard file, 3-inch, half round, with handle.
- 1 pair tweezers, 4½ inch, nickel.
- 1 screw-driver, 2-inch.
- 1 rule, 2-foot, narrow, four-fold, boxwood, brass bound.

WIRE.

The types of wire described in the following paragraphs are those most commonly used in Signal Corps work. Requisitions for material of this character should be confined as far as possible to the types of wire described.

Hard-drawn copper wire No. 14.—This wire weighs 65 pounds per mile and is furnished in coils of 1-mile length. It is used for telephone and telegraph lines where low ohmic resistance is required and the climatic conditions are not suitable for the use of iron wire.

Hard-drawn copper wire No. 12.—This wire weighs 105 pounds per mile and is furnished in coils of 1-mile length. This wire is used for the same purposes as the No. 14 wire, but provides greater mechanical strength with lower ohmic resistance.

No. 14 galvanized-iron wire.—This wire weighs 96 pounds per mile and is furnished in coils of 1-mile length. A grade most commonly used for Signal Corps work is known as *E B B*, and is used for telephone and telegraph lines where the lines are of short length or temporary in character. This wire has a high tensile strength, but the ohmic resistance is also higher than that of copper and the iron wire deteriorates from exposure to the weather.

No. 9 galvanized-iron wire weighs 305 pounds per mile and is furnished in coils of one-half mile lengths. This wire is used for telegraph lines in exposed locations where high tensile strength is required.

Outside twisted pair wire No. 14.—This wire weighs 398 pounds per mile and is furnished in coils of about 500 feet in length. The copper conductor is rubber covered and braided. This wire is used for drop wires and for telephone and telegraph lines where an insulated wire is necessary.

Outside twisted pair wire No. 12 is issued in coils of about 500 feet in length, and is used for the same purposes as the smaller size of this wire, but provides greater tensile strength and conductivity.

Field wire, 11-strand.—This wire weighs about 75 pounds per mile and is furnished in coils or on spools of about one-half mile length.

It is composed of 10 strands of steel and 1 strand of copper wire insulated with rubber and covered with a saturated braid. This wire is used for field lines for telephone or telegraph service and is issued to field companies of the Signal Corps. It will withstand a breaking strain of 220 pounds.

Buzzer wire.—This wire is composed of 2 steel strands and 1 copper strand laid together and covered by a light insulation. The wire is wound on spools 6 inches in diameter and 3 inches along the axis, each containing one-half mile of wire and weighing 10 pounds. The buzzer wire has a breaking strength of about 67 pounds and is intended for use over short distances or over a terrain where it is impracticable to lay wire from a reel cart.

Antenna wire is composed of 7 strands of No. 20 phosphor bronze wire equivalent to about No. 12, B. & S. gauge. This wire provides great strength with good conductivity. It is issued for field wireless pack sets and for use in antennæ for all wireless stations.

Antenna cord is made up of stranded phosphor bronze wires equivalent to No. 16, B. & S. gauge. It is more flexible than antenna wire and is issued for field wireless pack sets.

Field artillery wire, twin conductor, is issued for use of the Field Artillery for telephone lines. This wire has two conductors insulated with rubber and covered with a common braid. It provides a metallic circuit, thus avoiding the use of field ground rods in this connection.

Inside twisted pair wire is furnished in coils of 500 feet in length, and is equivalent to No. 19, B. & S. gauge. It is issued for fire-control work at coast artillery posts and is used for inside wiring and cross connections.

House wire is furnished in coils of 500 feet in length, the conductor being No. 19 copper. This wire is used for all inside or house wiring at posts other than fire control.

Bridle wire is issued in coils of 500 feet in length and is used for connecting aerial line wires to pole terminals.

Pothead wire is issued in coils of 500 feet in length and is used in insulating the terminals of conductors of paper-insulated cable.

Cross connecting wire is furnished in coils of 500 feet in length for making cross connections in terminal boxes and distributing frames.

Cable core consists of a conductor of 7 No. 20 copper wires covered with a high grade of rubber compound. This is issued for use as a counterpoise for field wireless pack sets.

Instrument wire has a stranded copper conductor covered with rubber and an outside braid. This wire is used in wiring fire-control telephones and similar instruments. It is furnished in various colors to conform to color codes for the various instruments.

Zone signal wire is furnished for wiring zone signal apparatus at fire-control installations. This wire has a stranded conductor with rubber insulation and outside braid. It is furnished in red and black.

Splicing field wire.—When field wire has been broken or cut, it will necessarily have to be spliced. Splices in field wires may be either temporary or permanent in character. If the wire is severed while in use, the line guard should locate the fault and complete the splice as quickly as possible. A temporary splice may be made as follows: The two ends of the severed wire having been caught up the ends are scraped of insulation (skinned) after a square knot has first been tied by knotting the two ends of the wire together. This knot is made to take the strain off of the splice. Care in making the square knot should be observed, so that a granny knot may not result. After knotting the wire the skinned ends are then twisted tightly together.

As soon as convenient the wire should be gone over, the bad lengths cut out, and permanent splices made in place of the temporary ones. To make a permanent splice, skin off the insulation for about 4 inches on each end and separate the steel and copper strands, so that the two copper strands may first be wound tightly together. The copper may be distinguished from the steel by its greater pliability. The steel strands are now wound together making the joint mechanically secure. Snap off the loose ends and solder the joint. Wind insulating tape tightly over the splice.

The double conductor wire, field artillery type, *should never be cut.* Model B buzzer connectors are furnished for “clipping” on this wire and the telephones are in turn connected to the binding posts of the connectors by cords specially provided for that purpose. If this wire becomes severed proceed as follows: Remove the outer coating of insulation for about 1 foot on each loose end and separate the two conductors. Cut about 6 inches off of one conductor on each end as shown in the figure. Complete splice for each separate conductor as described for single conductor. The whole joint is then taped up.

FIELD INDUCTION TELEGRAPH SET.

The field induction telegraph set is designed for sending Morse signals over field lines of communication and may be used for this purpose in all cases where the buzzer is so employed. It can not be used, however, for the transmission of speech. The general appearance of the instrument is shown in figure 204. The top of the instrument is shown open with a card of instructions and the wiring diagram on its inner surface. The front side of the box is hinged at the bottom and opens out and acts as an operating shelf on which the sending key is mounted. The circuits of the set are shown in figure 205. By reference to this figure it will be seen that there are three

principal circuits: First, the primary circuit, comprising sending key, three cells of battery, and coarse wire winding of the induction coil in series; second, the secondary circuit, comprising the two windings of the polarized relay in series, the fine wire winding of the induction coil, line and ground connections; third, the local sounder circuit, comprising one cell of local battery, battery switch, sounder and relay contacts in series. The operation of the set is as follows: When the sending key is closed, battery flows through the coarse wire winding of the induction coil, inducing a momentary current in the fine wire



FIG. 204.—Field induction set.

winding which passes through the relay windings and a similar circuit at the distant station. The relay contacts are closed during the time this current flows and remain closed until the key is opened, when the discharge of the induction coil being in the opposite direction from the original current opens the relay contacts and releases the sounder. The advantages of the field induction telegraph set are the ease of continuous sending with the standard telegraph key, the audible signals produced by the local sounder circuit, and the sensitiveness of the polarized relay to a small current. The speed in send-

ing is also greater than is possible with the various types of buzzers. On the other hand, the instrument requires more careful adjustment for satisfactory service and is more difficult to maintain in perfect operating condition.

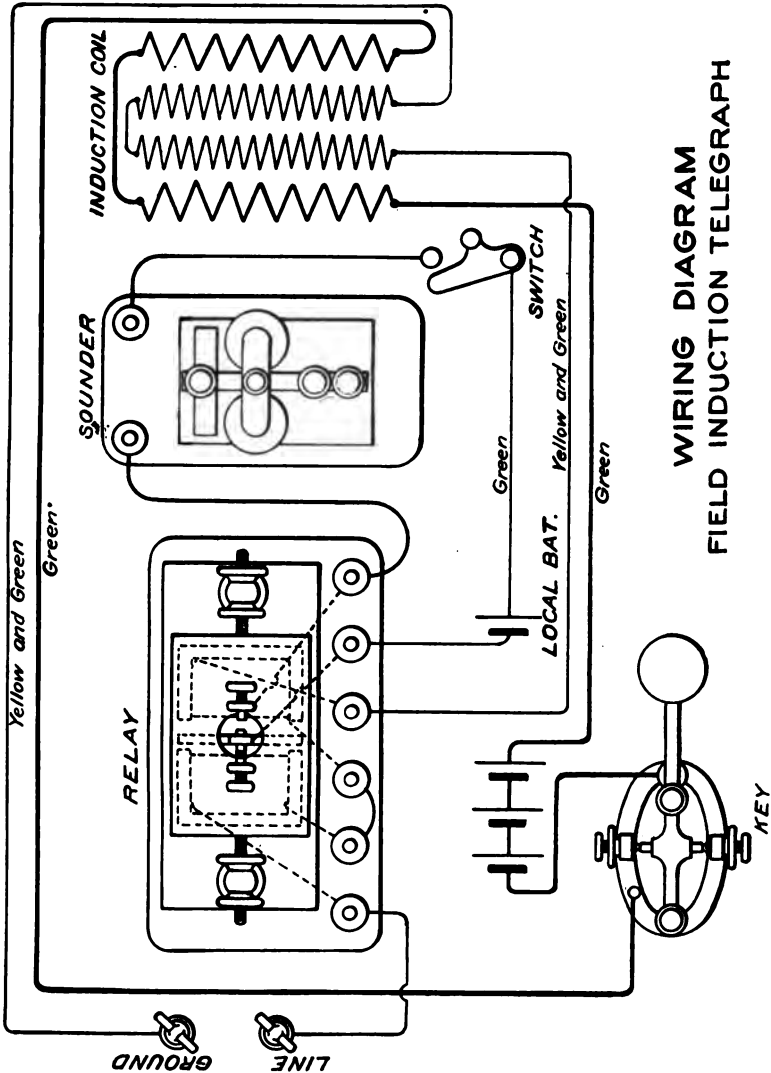

WIRING DIAGRAM
FIELD INDUCTION TELEGRAPH

FIG. 205.

For operating the set should be placed in a position as level and solid as possible. The relay magnets should be adjusted with the screws at each end so that the curved pole pieces are about one-eighth inch from the armature.

The top adjusting screw is then set so the tongue of relay will lie against either front or back stop indifferently. The play of tongue should not exceed one thirty-second of an inch. When line and ground are connected, if your own sending is reversed, transpose the wires connected to first and fourth binding posts of relay, counting from left, or transpose the wires connected with positive and negative poles of main (3-cell) battery. If signals from distant stations come reversed, transpose line and ground connections.

In case of trouble with local, it will be found that on ordinary lines, by giving the tongue of relay a play of about one-eighth inch and opening the glass cover, the sound of the relay will answer in quiet situations.

The general dimensions of this set are: Height, $7\frac{1}{2}$ inches; length, $12\frac{1}{8}$ inches; width, $6\frac{3}{8}$ inches.

CHAPTER X.

MISCELLANEOUS TABLES AND INFORMATION.^a

UNITS OF RESISTANCE.

The unit of resistance now universally used is the international ohm. The following multiples of this unit are sometimes employed:

Ohms.
Megohm=1,000,000.
Microhm=0.000,001.

The following table gives the value of the principal practical units of resistance which existed previous to the establishment of the international units:

Unit.	Internation- al ohm.	B. A. ohm.	Legal ohm, 1884.	Siemens's ohm.
International ohm.....	1.000	1.0136	1.0028	1.0630
B. A. ohm.....	.9866	1.000	.9894	1.0488
Legal ohm.....	.9972	1.0107	1.000	1.0600
Siemens's ohm.....	.9407	.9535	.9434	1.000

Thus, to reduce British Association ohms to international ohms we divide by 1.0136, or multiply by 0.9866; and to reduce legal ohms to international ohms we divide by 1.0028, or multiply by 0.9972, etc.

SPECIFIC RESISTANCE.

Let l = length of the conductor.
 A = cross section of the conductor.
 R = resistance of the conductor.
 ρ = specific resistance of the conductor.

Then $R = \rho \frac{l}{A}$,

or $\rho = R \frac{A}{l}$.

If l is measured in centimeters and A in square centimeters, ρ is the resistance of a centimeter cube of the conductor. If l is measured in inches and A is square inches, ρ is the resistance of an inch cube of the conductor.

^a Data from Foster's Electrical Engineer's Pocketbook, by permission of the publishers. D. Van Nostrand Company, New York.

In telegraph and telephone practice, specific resistance is sometimes expressed as the *weight per mile-ohm*, which is the weight in pounds of a conductor 1 mile long having a resistance of 1 ohm.

Another common way of expressing specific resistance is in terms of *ohms per mil-foot*, i. e., the resistance of a round wire 1 foot long and 0.001 inch in diameter; l is then measured in feet and A in circular mils.

Microhms per inch cube = $0.3937 \times$ microhms per centimeter cube.

Pounds per mile-ohm = $57.07 \times$ microhms per centimeter cube \times specific gravity.

Ohms per mil-foot = $6.015 \times$ microhms per centimeter cube.

Specific conductivity is the reciprocal of specific resistance. If c = specific conductivity,

$$R = \frac{l}{cA},$$

$$c = \frac{l}{RA},$$

$$c = \frac{1}{\rho}.$$

By relative or percentage conductivity of a sample is meant 100 times the ratio of the conductivity of the sample at standard temperature to the conductivity of a conductor of the same dimensions made of the standard material and at standard temperature. If ρ_0 is the specific resistance of the sample at standard temperature and ρ_s is the specific resistance of the standard at standard temperature, then

$$\text{Percentage conductivity} = 100 \frac{\rho_s}{\rho_0}.$$

In comparing different materials, the specific resistance should always be determined at the standard temperature, which is usually taken as 0° centigrade. If it is inconvenient to measure the resistance of the sample at the standard temperature, this may be readily calculated if the temperature coefficient a of the sample is known, i. e.,

$$\rho_0 = \frac{\rho_t}{1 + at}$$

where ρ_t is the specific resistance at temperature t .

Matthiessen's standard of conductivity, which is the commercial standard, is a copper wire having the following properties at the standard temperature of 0° centigrade:

Specific gravity.....	8.89.
Length.....	1 meter.
Weight.....	1 gram.
Resistance.....	0.141729 ohms.
Specific resistance.....	1.594 microhms per cubic centimeter.
Relative conductivity.....	100 per cent.

Specific resistance, relative resistance, and relative conductivity of conductors.

[Referred to Matthiessen's standard.]

Metals.	Resistance in microhms at 0° C.		Relative resistance.	Relative conductivity.
	Centimeter cube.	Inch cube.		
Silver, annealed	1.47	0.572	Per cent. 92.5	Per cent. 108.2
Copper, annealed	1.55	.610	97.5	102.6
Copper (Matthiessen's standard)	1.594	.6276	100	100
Gold (99.9 per cent pure)	2.20	.865	139	72.5
Aluminum (99 per cent pure)	2.56	1.01	161	62.1
Zinc	5.75	2.26	362	27.6
Platinum, annealed	8.98	3.53	565	17.7
Iron	9.07	3.57	570	17.6
Nickel	12.5	4.85	778	12.9
Tin	13.1	5.16	828	12.1
Lead	20.4	8.04	1,290	7.82
Antimony	35.2	13.9	2,210	4.58
Mercury	94.3	37.1	5,980	1.69
Bismuth	180	51.2	8,220	1.22
Carbon (graphitic)	2,400-42,000	950-16,700		
Carbon (arc light)	about 4,000	about 1,590		
Selenium	6 × 10 ¹⁰	2.38 × 10 ¹⁰		

Resistances of liquid conductors.

Liquids at 18° C.	Ohms per centimeter cube.	Ohms per inch cube.
Pure water	2650	1050
Sea water	30	11.8
Sulphuric acid:		
5 per cent.	4.86	1.93
30 per cent.	1.37	.544
80 per cent.	9.18	3.64
Nitric acid, 30 per cent.	1.29	.512
Zinc sulphate, 24 per cent.	21.4	8.54

TEMPERATURE COEFFICIENT.

The resistance of a conductor varies with the temperature of the conductor.

Let R_0 = resistance at 0°.

R = resistance at t °.

$$\text{Then } R = R_0 (1 + a t).$$

a is called the *temperature coefficient* of the conductor; $100 a$ is the percentage change in resistance per degree change in temperature.

The following values of the temperature coefficient have been found for temperatures measured in degrees Centigrade and in degrees Fahrenheit. It is to be noted that the coefficients vary considerably with the purity of the conductor.

Pure metals.	Centi- grade a	Fahren- heit a
Silver, annealed	0.00400	0.00222
Copper, annealed00428	.00242
Gold (99.9 per cent)00377	.00210
Aluminum (99 per cent)00423	.00225
Zinc00406	.00226
Platinum, annealed00247	.00137
Iron00625	.00347
Nickel0062	.00345
Tin00440	.00245
Lead00411	.00228
Antimony00389	.00216
Mercury00072	.00044
Bismuth00354	.00197

Matthiessen's formula for soft copper wire $R=R_0(1+.00387t+.00000597t^2)$.

The wire used by Matthiessen was as pure as could be obtained at the time (1860), but in reality contained considerable impurities; the above formula, therefore, is not generally applicable. Later experiments have shown that for all practical work the above equation for copper wire may be written $R=R_0(1+.0042t)$ for t in ° C.

WIRE GAUGES.

The sizes of wires are ordinarily expressed by an arbitrary series of numbers. Unfortunately there are several independent numbering methods, so that it is always necessary to specify the method or wire gauge used. The following table gives the numbers and diameters in decimal parts of an inch for the various wire gauges used in this country and England:

Number of wire gauge.	Roebing or Washburn & Moens.	Brown & Sharpe.	Birmingham or Stubs.	English legal standard.	Old English or London.
	<i>Inch.</i>	<i>Inch.</i>	<i>Inch.</i>	<i>Inch.</i>	<i>Inch.</i>
6-0	0.460			0.464	
5-0	.450			.452	
4-0	.398	0.4600	0.464	.400	0.4510
3-0	.362	.4096	.425	.372	.4250
2-0	.331	.3648	.390	.348	.3800
0	.307	.3249	.340	.324	.3400
1	.283	.2898	.300	.300	.3000
2	.263	.2576	.284	.276	.2840
3	.244	.2294	.259	.252	.2590
4	.225	.2043	.238	.232	.2380
5	.207	.1819	.220	.212	.2200
6	.192	.1620	.203	.192	.2030
7	.177	.1443	.180	.176	.1800
8	.162	.1285	.165	.160	.1650
9	.148	.1144	.148	.144	.1480
10	.135	.1019	.134	.128	.1340
11	.120	.09074	.120	.116	.1200
12	.106	.08081	.109	.104	.1090
13	.092	.07196	.095	.092	.0950
14	.080	.06408	.085	.080	.0850
15	.072	.05706	.072	.072	.0720
16	.063	.05082	.065	.064	.0650
17	.054	.04525	.058	.056	.0580
18	.047	.04030	.049	.048	.0490
19	.041	.03589	.042	.040	.0400
20	.035	.03196	.035	.036	.0350
21	.032	.02846	.032	.032	.0315
22	.028	.02534	.028	.028	.0295
23	.025	.02257	.025	.024	.0270
24	.023	.02010	.022	.022	.0250
25	.020	.01790	.020	.020	.0230
26	.018	.01584	.018	.018	.0205
27	.017	.01419	.016	.0164	.01875
28	.016	.01264	.014	.0148	.01650
29	.015	.01125	.013	.0136	.01550
30	.014	.01002	.012	.0124	.01375
31	.0135	.00893	.010	.0116	.01225
32	.0130	.00795	.009	.0108	.01125
33	.0110	.00708	.008	.0100	.01025
34	.0100	.00630	.007	.0092	.0095
35	.0095	.00561	.005	.0084	.0090
36	.0090	.00500	.004	.0076	.0075
37	.0085	.00445		.0068	.0065
38	.0080	.00397		.0060	.0057
39	.0075	.00353		.0052	.0050
40	.0070	.00314		.0048	.0045

Roebbling gauge.—Used almost universally in this country for iron and steel wire.

Brown & Sharpe gauge.—The American standard for wires for electrical purposes.

Birmingham gauge.—Used largely in England and also in this country for wires other than those made especially for electrical purposes, excepting iron wire.

LAW OF THE BROWN & SHARPE GAUGE.

The diameters of wires on the B. & S. gauge are obtained from the geometric series in which No. 0000=0.4600 inch and No. 36=.005 inch, the nearest fourth significant figure being retained in the areas and diameters so deduced.

Let n = gauge number (0000 = - 3; 000 = - 2; 00 = - 1).

d = diameter of wire in inches.

$$\text{Then } d = \frac{0.3249}{1.123^n}.$$

Sheathing core.—The number (N) of sheathing wires having a diameter (d) which will cover a core having a diameter (D) is

$$N = \pi \frac{D+d}{d}.$$

Tensile strength of copper wire.

COMMERCIAL STANDARDS.

Numbers, B. & S. gauge.	Breaking weight.		Numbers, B. & S. gauge.	Breaking weight.	
	Hard- drawn.	Annealed.		Hard- drawn.	Annealed.
	<i>Pounds.</i>	<i>Pounds.</i>		<i>Pounds.</i>	<i>Pounds.</i>
0000	8,310	5,650	9	617	349
000	6,580	4,480	10	489	277
00	5,226	3,553	11	388	219
0	4,558	2,818	12	307	174
1	3,746	2,281	13	244	138
2	3,127	1,772	14	198	109
3	2,480	1,405	15	158	87
4	1,967	1,114	16	133	69
5	1,559	883	17	97	55
6	1,237	700	18	77	43
7	980	555	19	61	34
8	778	440	20	48	27

The strength of soft copper wire varies from 32,000 to 36,000 pounds per square inch, and of hard copper wire from 45,000 to 68,000 pounds per square inch, according to the degree of hardness.

The above table is calculated for 34,000 pounds for soft wire and 60,000 pounds for hard wire, except for some of the larger sizes, where the breaking weight per square inch is taken at 50,000 pounds for 0000, 000, and 00, 55,000 for 0, and 57,000 pounds for 1.

Hard-drawn copper telephonè and telegraph wire.

COMMERCIAL VALUES.

Size B. & S. guage.	Resistance per mile.	Breaking strength.	Weight per mile.	Furnished in coils as follows.	Approximate size E. B. B. iron wire equal to copper.
	<i>Ohms</i>	<i>Pounds.</i>	<i>Pounds.</i>	<i>Miles.</i>	
9	4.30	625	209	1	2
10	5.40	525	166	1.2	3
11	6.90	420	131	.52	4
12	8.70	330	104	.65	6
13	10.90	270	88	1.20	6½
14	13.70	213	66	1.50	8
15	17.40	170	52	2.00	9
16	22.10	130	41	1.20	10

In handling this wire the greatest care should be observed to avoid kinks, bends, scratches, or cuts. Joints should be made only with copper splicing sleeves and connectors.

On account of its conductivity being about five times that of Ex. B. B. iron wire, and its breaking strength over three times its weight per mile, copper may be used of which the section is smaller and the weight less than an equivalent iron wire, allowing a greater number of wires to be strung on the poles.

Besides this advantage, the reduction of section materially decreases the electrostatic capacity, while its nonmagnetic character lessens the self-induction of the line, both of which features tend to increase the possible speed of signaling in telegraphing, and to give greater clearness of enunciation over telephone lines, especially those of great length.

COMMERCIAL STANDARDS.

Standard copper strands.

C. M.	Wires.		Outside diameter.	Weight per 1,000 feet.
	Number.	Size.		
		<i>Inch.</i>	<i>Inches.</i>	<i>Pounds.</i>
2,000,000	127	0.1255	1.632	6,100
1,950,000	127	.1239	1.611	5,948
1,900,000	127	.1223	1.590	5,795
1,850,000	127	.1207	1.569	5,643
1,800,000	127	.1191	1.548	5,490
1,750,000	127	.1174	1.526	5,338
1,700,000	91	.1367	1.504	5,185
1,650,000	91	.1347	1.482	5,033
1,600,000	91	.1326	1.459	4,880
1,550,000	91	.1305	1.436	4,728
1,500,000	91	.1284	1.412	4,575
1,450,000	91	.1262	1.388	4,423
1,400,000	91	.1240	1.364	4,270
1,350,000	91	.1218	1.340	4,118
1,300,000	91	.1195	1.315	3,965
1,250,000	91	.1172	1.289	3,813
1,200,000	61	.1403	1.263	3,660
1,150,000	61	.1373	1.236	3,508
1,100,000	61	.1343	1.209	3,355
1,050,000	61	.1312	1.181	3,203
1,000,000	61	.1280	1.152	3,050
950,000	61	.1247	1.122	2,898
900,000	61	.1214	1.093	2,745
850,000	61	.1180	1.062	2,593
800,000	61	.1145	1.031	2,440
750,000	61	.1108	.997	2,288
700,000	61	.1071	.964	2,135
650,000	61	.1032	.929	1,983
600,000	61	.0991	.892	1,830
550,000	61	.0949	.854	1,678
500,000	61	.0905	.815	1,525
450,000	37	.1108	.772	1,373
400,000	37	.1039	.727	1,220
350,000	37	.0972	.680	1,068
300,000	37	.0900	.630	915
250,000	37	.0821	.575	763

Standard copper strands—Continued.

Size, B. & S.	Wires.		Outside diameter.	Weight per 1,000 feet.
	No.	Size.		
		<i>Inch.</i>	<i>Inch.</i>	<i>Pounds.</i>
0000	19	0.1055	0.528	645
000	19	.0941	.471	513
00	19	.0837	.419	406
0	19	.0746	.373	322
1	19	.0663	.332	255
2	7	.0975	.293	203
3	7	.0866	.260	160
4	7	.0771	.231	127
5	7	.0688	.206	101
6	7	.0612	.184	80
8	7	.0484	.145	50
10	7	.0386	.116	32
12	7	.0306	.092	20
14	7	.0242	.073	12
16	7	.0193	.058	8
18	7	.0151	.045	5

Carrying capacity of insulated copper wires for interior wiring.

NATIONAL ELECTRICAL CODE.

B. & S. Co.	Rubber-covered wires.		Weather-proof wires.	Rubber-covered wires.		Weather-proof wires.
	Circular.			Circular.		
	<i>Mils.</i>	<i>Amperes.</i>	<i>Amperes.</i>	<i>Mils.</i>	<i>Amperes.</i>	<i>Amperes.</i>
18	1,624	8	5	200,000	200	300
16	2,583	6	8	300,000	270	400
14	4,107	12	16	400,000	330	500
12	6,530	17	23	500,000	390	590
10	10,380	24	32	600,000	450	680
8	16,510	33	46	700,000	500	760
6	26,250	46	65	800,000	550	840
5	33,100	54	77	900,000	600	920
4	41,740	65	92	1,000,000	650	1,000
3	52,630	76	110	1,100,000	690	1,060
2	66,370	90	131	1,200,000	730	1,150
1	83,690	107	156	1,300,000	770	1,220
0	105,500	127	185	1,400,000	810	1,290
00	133,100	150	220	1,500,000	850	1,360
000	167,800	177	262	1,600,000	890	1,430
0000	211,600	210	312	1,700,000	930	1,490
				1,800,000	970	1,550
				1,900,000	1,010	1,610
				2,000,000	1,050	1,670

Carrying capacity of stranded copper conductors for interior wiring.

NATIONAL ELECTRICAL CODE.

B. & S. gauge.	Area actual C. M.	Number of strands.	Size of strand, B. & S. gauge.	Amperes.
19	1,298			
18	1,624			
17	2,048			
16	2,583			6
15	3,257			
14	4,107			12
12	6,530			17
	9,016	7	19	21
	11,368	7	18	25
	14,336	7	17	30
	18,081	7	16	35
	22,799	7	15	40
	30,856	19	18	50
	38,912	19	17	60
	49,077	19	16	70
	60,088	37	18	85
	75,776	37	17	100
	99,064	61	18	120
	124,928	61	17	145
	157,563	61	16	170
	198,877	61	15	200
	250,627	61	14	235
	296,887	91	15	270
	373,737	91	14	320
	413,639	127	15	340

For aluminum wire the carrying capacity of any given size is to be taken as 84 per cent of the value given in the above table.

REFERENCE TABLES FOR TESTER.

Table of dimensions, weight, and length of pure copper wire.

Size, B. & S.	Diameter.	Circular, mils. (d^2). 1 mil. = .001 in.	Pounds per 1,000 feet.	Pounds per mile.	Feet per pound.
	<i>Mils.</i>				
0000	460.000	211600.00	689.33	3375.7	1.56
000	409.640	167806.00	567.01	2677.0	1.97
00	364.900	133079.40	402.09	2123.0	2.49
0	324.860	105538.00	318.86	1638.6	3.14
1	289.300	83694.20	252.88	1335.2	3.95
2	257.630	66373.00	200.54	1058.8	4.99
3	229.420	52634.00	159.03	839.68	6.29
4	204.310	41742.00	126.12	665.91	7.93
5	181.940	33102.00	100.01	528.05	10.00
6	162.020	26250.50	79.32	418.81	12.61
7	144.280	20816.00	62.90	332.11	15.90
8	128.490	16509.00	49.88	263.37	20.05
9	114.430	13094.00	39.56	206.88	25.28
10	101.890	10381.00	31.37	165.63	31.38
11	90.742	8234.00	24.88	131.37	40.20
12	80.908	6529.90	19.73	104.18	50.69
13	71.961	5178.40	15.65	82.632	63.91
14	64.048	4106.70	12.44	65.674	80.38
15	57.068	3256.7	9.84	51.966	101.63
16	50.820	2582.9	7.81	41.237	128.14
17	45.257	2048.2	6.19	32.683	161.59
18	40.303	1624.3	4.91	25.925	203.76
19	35.876	1287.1	3.88	20.507	257.47
20	31.961	1021.5	3.09	16.315	324.00
21	28.462	810.10	2.45	12.936	406.56
22	25.347	642.70	1.94	10.243	515.15
23	22.571	509.45	1.54	8.1312	649.66
24	20.100	404.01	1.22	6.4416	819.21
25	17.900	320.40	.97	5.1216	1032.96
26	15.940	254.01	.77	4.0656	1302.61
27	14.195	201.50	.61	3.2208	1642.55
28	12.641	159.79	.48	2.5344	2071.22
29	11.257	126.72	.38	2.0064	2611.82
30	10.025	100.5	.30	1.5840	3293.97
31	8.928	79.71	.24	1.2672	4152.22
32	7.950	63.20	.19	1.0032	5236.66
33	7.080	50.13	.15	.7920	6602.71
34	6.304	39.74	.12	.6336	8323.30
35	5.614	31.52	.10	.5280	10501.35
36	5.000	25.00	.08	.4224	13238.83
37	4.453	19.83	.06	.3168	16691.06
38	3.965	15.72	.05	.2640	20854.65
39	3.531	12.47	.04	.2112	26302.23
40	3.144	9.89	.03	.1584	33175.94

RUBBER COMPOUNDS.

In reducing the insulation resistance of Okonite, Habirshaw, or Bishop compounds to 60° F., the total difference between the temperature of observation and the standard temperature, 60°, will be determined and the proper coefficient will be found by referring to the table. For example, if the temperature were 75°, the difference of temperature, 15°, would call for a coefficient of 1.470, by which the insulation resistance, as calculated, will be multiplied to determine the correct value at 60° F.

Temperature coefficients for the reduction of insulation resistance to 60° F.

OKONITE, HABIRSHAW, AND BISHOP COMPOUNDS.

Difference of temperature.	Coefficient.	Difference of temperature.	Coefficient.	Difference of temperature.	Coefficient.
°F. 1	1.026	°F. 18	1.587	°F. 35	2.456
2	1.053	19	1.629	36	2.520
3	1.080	20	1.671	37	2.586
4	1.108	21	1.715	38	2.653
5	1.137	22	1.759	39	2.722
6	1.167	23	1.805	40	2.793
7	1.197	24	1.852	41	2.865
8	1.228	25	1.900	42	2.940
9	1.260	26	1.949	43	3.016
10	1.293	27	2.000	44	3.091
11	1.326	28	2.052	45	3.175
12	1.361	29	2.105	46	3.258
13	1.396	30	2.160	47	3.342
14	1.433	31	2.216	48	3.429
15	1.470	32	2.274	49	3.518
16	1.508	33	2.333	50	3.610
17	1.547	34	2.394		

Temperature.	K.	Log. K.	Temperature.	K.	Log. K.
°F. 50	0.773	9.888401	°F. 66	1.167	0.067071
51	.793	9.899629	67	1.197	.078094
52	.814	9.910802	68	1.228	.089198
53	.835	9.921906	69	1.260	.100371
54	.856	9.932929	70	1.293	.111599
55	.879	9.944240	71	1.326	.122544
56	.902	9.955460	72	1.361	.133858
57	.925	9.966576	73	1.396	.144885
58	.949	9.977572	74	1.433	.156246
59	.974	9.988853	75	1.470	.167317
60	1.000	.000000	76	1.508	.178401
61	1.026	.011147	77	1.547	.189490
62	1.053	.022428	78	1.587	.200577
63	1.080	.033424	79	1.629	.211921
64	1.108	.044540	80	1.671	.222976
65	1.137	.055760			

To correct insulation resistance for temperature where the cables are made up of Safety, Kerite, or Standard underground rubber compounds, reference should be had to one of the following tables for the temperature coefficient at the observed temperature. The correct resistance is obtained by multiplying the calculated resistance by the coefficient found in the table for that compound opposite the observed temperature.

SAFETY COMPOUND.

Temperature.	Coefficient.	Temperature.	Coefficient.	Temperature.	Coefficient.
°F. 20	0.4399	°F. 47	0.7386	°F. 74	1.4407
21	.4472	48	.7551	75	1.4511
22	.4547	49	.7721	76	1.5228
23	.4625	50	.7897	77	1.5647
24	.4705	51	.8078	78	1.6110
25	.4787	52	.8265	79	1.6728
26	.4869	53	.8458	80	1.7056
27	.4959	54	.8658	81	1.7566
28	.5049	55	.8864	82	1.8073
29	.5141	56	.9076	83	1.8610
30	.5237	57	.9296	84	1.9167
31	.5336	58	.9523	85	1.9744
32	.5437	59	.9758	86	2.0343
33	.5542	60	1.0000	87	2.0964
34	.5648	61	1.0251	88	2.1609
35	.5759	62	1.0510	89	2.2278
36	.5873	63	1.0777	90	2.2973
37	.5990	64	1.1054	91	3.3694
38	.6112	65	1.1340	92	2.4443
39	.6236	66	1.1636	93	2.5223
40	.6361	67	1.1943	94	2.6028
41	.6498	68	1.2260	95	2.6868
42	.6635	69	1.2587	96	2.7740
43	.6776	70	1.2927	97	2.8646
44	.6921	71	1.3278	98	2.9587
45	.7071	72	1.3641	99	3.0566
46	.7226	73	1.4017	100	3.1584

KERITE COMPOUND.

Temperature.	Coefficient.	Temperature.	Coefficient.	Temperature.	Coefficient.
°F. 20	0.2706	°F. 47	0.5187	°F. 74	2.6023
21	.2725	48	.5413	75	2.8410
22	.2747	49	.5655	76	3.0469
23	.2774	50	.5917	77	3.3035
24	.2804	51	.6199	78	3.5865
25	.2839	52	.6503	79	3.8988
26	.2877	53	.6831	80	4.2438
27	.2921	54	.7184	81	4.6256
28	.2968	55	.7566	82	5.0483
29	.3020	56	.7979	83	5.5169
30	.3078	57	.8426	84	6.0371
31	.3141	58	.8909	85	6.6149
32	.3209	59	.9433	86	7.2577
33	.3283	60	1.0000	87	7.9734
34	.3363	61	1.0616	88	8.7713
35	.3449	62	1.1281	89	9.6617
36	.3543	63	1.2010	90	10.6566
37	.3644	64	1.2800	91	11.7695
38	.3752	65	1.3660	92	13.0158
39	.3869	66	1.4597	93	14.4130
40	.3995	67	1.5618	94	15.9814
41	.4131	68	1.6722	95	17.7438
42	.4276	69	1.7952	96	19.7265
43	.4433	70	1.9285	97	21.9698
44	.4601	71	2.0744	98	24.4782
45	.4782	72	2.2343	99	27.3215
46	.4977	73	2.4097	100	30.5353

STANDARD UNDERGROUND COMPANY'S RUBBER "D."

Temperature.	Coefficient.	Temperature.	Coefficient.	Temperature.	Coefficient.
°F.		°F.		°F.	
20	0.5636	47	0.8051	74	1.2970
21	.5608	48	.8179	75	1.3227
22	.5672	49	.8311	76	1.3491
23	.5742	50	.8446	77	1.3762
24	.5814	51	.8584	78	1.4041
25	.5888	52	.8726	79	1.4328
26	.5964	53	.8872	80	1.4622
27	.6041	54	.9021	81	1.4924
28	.6120	55	.9174	82	1.5235
29	.6201	56	.9331	83	1.5554
30	.6284	57	.9492	84	1.5883
31	.6369	58	.9657	85	1.6220
32	.6456	59	.9826	86	1.6568
33	.6546	60	1.0000	87	1.6924
34	.6626	61	1.0178	88	1.7291
35	.6731	62	1.0361	89	1.7669
36	.6827	63	1.0549	90	1.8057
37	.6925	64	1.0741	91	1.8457
38	.7026	65	1.0939	92	1.8867
39	.7129	66	1.1141	93	1.9290
40	.7234	67	1.1349	94	1.9725
41	.7343	68	1.1563	95	2.0173
42	.7454	69	1.1782	96	2.0633
43	.7567	70	1.2007	97	2.1107
44	.7684	71	1.2239	98	2.1595
45	.7803	72	1.2476	99	2.2098
46	.7925	73	1.2720	100	2.2615

Table of resistances of pure copper wire at 75° F.

Size, B. & S.	Ohms per 1,000 feet.	Ohms per mile.	Ohms per pound.	Feet per ohm.
0000	0.04906	0.25908	0.000076736	20,383.0
000	.06136	.32664	.00012039	16,165.0
00	.07801	.41187	.00019423	12,820.0
0	.09838	.51987	.00038500	10,166.0
1	.12404	.65490	.00048994	8,062.3
2	.15640	.82582	.00078045	6,398.7
3	.19723	1.0414	.0012406	5,070.2
4	.24869	1.3181	.0019721	4,021.0
5	.31361	1.6558	.0031361	3,188.7
6	.39546	2.0881	.0049868	2,528.7
7	.49871	2.6331	.0079294	2,005.2
8	.62881	3.3201	.012608	1,590.3
9	.79281	4.1860	.020042	1,261.3
10	1.0000	5.2800	.031380	1,000.0
11	1.2607	6.6568	.050682	798.18
12	1.5898	8.3940	.080595	629.02
13	2.0047	10.585	.12841	498.83
14	2.5278	13.347	.20322	395.60
15	3.1150	16.477	.31658	321.02
16	4.0191	21.221	.51501	248.81
17	5.0683	26.761	.81900	197.30
18	6.3911	33.745	1.3023	156.47
19	8.0654	42.585	2.0759	123.99
20	10.163	53.658	3.2925	98.401
21	12.815	67.660	5.2355	78.067
22	16.152	85.283	8.3208	61.911
23	20.377	107.59	13.238	49.087
24	25.695	135.67	21.050	38.918
25	32.400	171.07	33.466	30.864
26	40.868	215.79	35.235	24.469
27	51.519	272.02	84.644	19.410
28	64.966	343.02	134.56	15.393
29	81.921	432.54	213.96	12.207
30	103.30	545.39	340.25	9.6812
31	127.27	671.99	528.45	7.8573
32	164.26	867.27	860.33	6.0880
33	207.08	1,093.4	1,367.3	4.8290
34	261.23	1,379.3	2,175.5	3.8281
35	329.35	1,738.9	3,458.5	3.0363
36	415.24	2,192.5	5,497.4	2.4082
37	523.76	2,765.5	8,742.1	1.9098
38	660.37	3,486.7	13,772	1.5143
39	832.48	4,395.5	21,896	1.2012
40	1,049.7	5,542.1	34,823	.9527

The resistance of copper increases with the increase of temperature. In order to reduce copper resistances at any temperature between 0° and 120° F. to 60° F., the following table has been calculated, in which δ is the factor by which the resistance at the observed temperature should be multiplied to reduce it to 60° F.:

Reduction of copper resistance to 60° F.

Temperature.	δ	Temperature.	δ	Temperature.	δ
° F. 0	1.1538	° F. 41	1.0443	° F. 82	0.9529
1	1.1509	42	1.0419	83	.9508
2	1.1480	43	1.0395	84	.9488
3	1.1451	44	1.0371	85	.9468
4	1.1422	45	1.0347	86	.9448
5	1.1393	46	1.0323	87	.9428
6	1.1364	47	1.0300	88	.9408
7	1.1336	48	1.0276	89	.9388
8	1.1308	49	1.0252	90	.9368
9	1.1280	50	1.0229	91	.9348
10	1.1252	51	1.0206	92	.9328
11	1.1224	52	1.0182	93	.9308
12	1.1196	53	1.0159	94	.9288
13	1.1168	54	1.0136	95	.9269
14	1.1141	55	1.0113	96	.9250
15	1.1113	56	1.0090	97	.9231
16	1.1086	57	1.0068	98	.9211
17	1.1059	58	1.0045	99	.9192
18	1.1032	59	1.0023	100	.9173
19	1.1005	60	1.0000	101	.9154
20	1.0978	61	.9978	102	.9135
21	1.0952	62	.9956	103	.9116
22	1.0925	63	.9933	104	.9097
23	1.0899	64	.9911	105	.9079
24	1.0873	65	.9889	106	.9060
25	1.0846	66	.9867	107	.9041
26	1.0820	67	.9846	108	.9022
27	1.0794	68	.9824	109	.9004
28	1.0769	69	.9802	110	.8986
29	1.0743	70	.9781	111	.8968
30	1.0717	71	.9759	112	.8949
31	1.0692	72	.9738	113	.8931
32	1.0667	73	.9717	114	.8913
33	1.0641	74	.9695	115	.8895
34	1.0616	75	.9674	116	.8877
35	1.0591	76	.9653	117	.8859
36	1.0566	77	.9632	118	.8841
37	1.0542	78	.9611	119	.8824
38	1.0517	79	.9591	120	.8806
39	1.0492	80	.9570		
40	1.0468	81	.9549		

A general formula for reducing copper resistance at any observed temperature (T) to 60° F. is given by the following:

$$\delta = \frac{1.063}{1 + .00225(T - 32)}$$

U.S. SIGNAL CORPS

TABLES OF TEMPERATURE COEFFICIENTS
FOR REDUCING CONDUCTOR AND INSULATION RESISTANCE
TO STANDARD TEMPERATURE

785
AUGUST 12, 1909
FROM
J. R. W.
DRAWN
W. W.
CHECKED
W. W.
D. R.
APPROVED
C. M. C.
REVIEWED

TEMP.	COPPER	EXPER. CORE	KERITE	SAFETY	TELEPHONE	
113	1.13359					
114	1.14222					
115	1.15085					
116	1.15948					
117	1.16811					
118	1.17674					
119	1.18537					
120	1.19400					
121	1.20263					
122	1.21126					
123	1.21989					
124	1.22852					
125	1.23715					
126	1.24578					
127	1.25441					
128	1.26304					
129	1.27167					
130	1.28030					
131	1.28893					
132	1.29756					
133	1.30619					
134	1.31482					
135	1.32345					
136	1.33208					
137	1.34071					
138	1.34934					
139	1.35797					
140	1.36660					
141	1.37523					
142	1.38386					
143	1.39249					
144	1.40112					
145	1.40975					
146	1.41838					
147	1.42701					
148	1.43564					
149	1.44427					
150	1.45290					
151	1.46153					
152	1.47016					
153	1.47879					
154	1.48742					
155	1.49605					
156	1.50468					
157	1.51331					
158	1.52194					
159	1.53057					
160	1.53920					
161	1.54783					
162	1.55646					
163	1.56509					
164	1.57372					
165	1.58235					
166	1.59098					
167	1.59961					
168	1.60824					
169	1.61687					
170	1.62550					
171	1.63413					
172	1.64276					
173	1.65139					
174	1.66002					
175	1.66865					
176	1.67728					
177	1.68591					
178	1.69454					
179	1.70317					
180	1.71180					
181	1.72043					
182	1.72906					
183	1.73769					
184	1.74632					
185	1.75495					
186	1.76358					
187	1.77221					
188	1.78084					
189	1.78947					
190	1.79810					
191	1.80673					
192	1.81536					
193	1.82399					
194	1.83262					
195	1.84125					
196	1.84988					
197	1.85851					
198	1.86714					
199	1.87577					
200	1.88440					
201	1.89303					
202	1.90166					
203	1.91029					
204	1.91892					
205	1.92755					
206	1.93618					
207	1.94481					
208	1.95344					
209	1.96207					
210	1.97070					
211	1.97933					
212	1.98796					
213	1.99659					
214	2.00522					
215	2.01385					
216	2.02248					
217	2.03111					
218	2.03974					
219	2.04837					
220	2.05700					
221	2.06563					
222	2.07426					
223	2.08289					
224	2.09152					
225	2.10015					
226	2.10878					
227	2.11741					
228	2.12604					
229	2.13467					
230	2.14330					
231	2.15193					
232	2.16056					
233	2.16919					
234	2.17782					
235	2.18645					
236	2.19508					
237	2.20371					
238	2.21234					
239	2.22097					
240	2.22960					
241	2.23823					
242	2.24686					
243	2.25549					
244	2.26412					
245	2.27275					
246	2.28138					
247	2.29001					
248	2.29864					
249	2.30727					
250	2.31590					
251	2.32453					
252	2.33316					
253	2.34179					
254	2.35042					
255	2.35905					
256	2.36768					
257	2.37631					
258	2.38494					
259	2.39357					
260	2.40220					
261	2.41083					
262	2.41946					
263	2.42809					
264	2.43672					
265	2.44535					
266	2.45398					
267	2.46261					
268	2.47124					
269	2.47987					
270	2.48850					
271	2.49713					
272	2.50576					
273	2.51439					
274	2.52302					
275	2.53165					
276	2.54028					
277	2.54891					
278	2.55754					
279	2.56617					
280	2.57480					
281	2.58343					
282	2.59206					
283	2.60069					
284	2.60932					
285	2.61795					
286	2.62658					
287	2.63521					
288	2.64384					
289	2.65247					
290	2.66110					
291	2.66973					
292	2.67836					
293	2.68699					
294	2.69562					
295	2.70425					
296	2.71288					
297	2.72151					
298	2.73014					
299	2.73877					
300	2.74740					
301	2.75603					
302	2.76466					
303	2.77329					
304	2.78192					
305	2.79055					
306	2.79918					
307	2.80781					
308	2.81644					
309	2.82507					
310	2.83370					
311	2.84233					
312	2.85096					
313	2.85959					
314	2.86822					
315	2.87685					
316	2.88548					
317	2.89411					
318	2.90274					
319	2.91137					
320	2.92000					
321	2.92863					
322	2.93726					
323	2.94589					
324	2.95452					
325	2.96315					
326	2.97178					
327	2.98041					
328	2.98904					
329	2.99767					
330	3.00630					
331	3.01493					
332	3.02356					
333	3.03219					
334	3.04082					



INDEX.

A.		Page.
“Acid batteries”.....		20
Accumulators.....		16, 27
Accuracy of telegraphy in comparison to telephony.....		289
Adjusting for maximum strength in telegraphy.....		96
Adjustment of telegraph apparatus.....		94
Adjustment of telegraph sounders.....		96
Aerial cable construction.....		208
Allowance of dry cells required by instruments.....		25
Ammeter.....		249
Ampere meter.....		249
Anchors.....		194
Anchor logs.....		184, 196
Anchor rod.....		196, 198
Apparatus, telegraph, adjustment of.....		94
Arms, buck.....		187
cross.....		184, 188
Arrangements, battery, of terminal office switchboard.....		67
Arrester cabinet.....		156
lightning.....		66, 180
Attaching cable to messenger.....		221
B.		
Balancing the polar duplex.....		92
Batteries, “acid”.....		20
classes of.....		16
closed circuit.....		16
Edison primary.....		18, 19, 20
Fuller.....		20, 21, 22
measuring internal resistance of.....		253
open circuit.....		16, 22
primary.....		16
secondary.....		16
service testing.....		262
storage. (See Storage batteries.)		
telautograph.....		53
telegraph.....		50
telephone storage.....		52
testing voltage of.....		251
voltammeter for testing of.....		272
Battery arrangements of terminal office switchboard.....		67
cells, storage, putting out of commission.....		49
room, light for.....		46
protective coatings.....		47
ventilation, temperature, and cleanliness of.....		46
troubles.....		43

	Page.
Bell, night.....	151
polarized.....	121
Birmingham gauge, wire.....	303
Bishop compound.....	309
Blocks, method of arranging.....	216
Box, cable.....	192, 205
relay.....	63
resistance, 100,000 ohm.....	260
Braces, pole.....	197, 200
Bracket lines.....	191
Brackets, location and method of attaching.....	192
Break in conductor, location of.....	248
Breast reels.....	290
“Bridge” method of duplex telegraphy.....	75, 76
Bridge, Wheatstone.....	254
Bridging type telephone, Signal Corps, circuits of.....	123
Bridle wire.....	295
Browne & Sharpe wire gauge.....	303, 304
Buck arms.....	187
“Butting” cable.....	168
Buzzer, cavalry.....	24, 107, 287
classification of circuits.....	107
connectors.....	287
models A and B.....	293
field.....	104, 287
primary circuit.....	105, 110
secondary circuit.....	106, 110
theory of.....	101
wire.....	286, 295
C.	
Cable.....	204
aerial, construction of.....	208
box.....	192, 205, 221
“butting”.....	168
capacity test of.....	269
core.....	295
distribution.....	209
faults.....	246, 273
field.....	286
forming.....	168
methods of testing.....	242
paper core.....	209
pulling.....	237
racking, in manholes.....	240
splices.....	220, 221, 222, 228
switchboard, color sequence, table of.....	170
standard sizes of Signal Corps.....	170
telephone. (See Telephone cable.)	
tester.....	265, 270
testing, continuity and identification.....	265
correction for leads and temperature.....	267
determination of galvanometer constant.....	267
duties of tester.....	265
insulation test.....	267

	Page.
Cable trenching.....	229
underground.....	229
Cabinet, arrester.....	156
terminal.....	149
Can top.....	209, 211, 212
Capacity of dielectric condensers.....	14
test of cables.....	269
Carrying capacity of insulated copper wires for interior wiring.....	307
stranded copper wires for interior wiring.....	307
Cart, wire.....	284
Case, electrical instrument.....	258, 263
Cavalry buzzers. (<i>See</i> Buzzers, cavalry.)	
Cells, chloride.....	39, 45
closed circuit, internal resistance of.....	16
table of.....	16
types of.....	16
voltage of.....	16
dry. (<i>See</i> Dry cells.)	
Edison Lalande.....	18
end.....	48
Gould.....	39, 45
gravity. (<i>See</i> Gravity cells.)	
grouping of.....	25
initial charges for different makes of.....	36
low.....	43
open circuit.....	16
"pilot," storage battery.....	37, 38, 39, 41
plates for.....	10
type V.....	18
voltaic.....	10
Willard.....	39, 45
Central energy storage battery.....	177
switchboard protectors.....	174
visual supervisory switchboard.....	148, 151
Charge, electrostatic, polarity of.....	13, 14
initial, for different types of cell.....	36
Charging panel.....	178
rate of storage batteries.....	31, 35, 38
Chemical action of storage batteries.....	27
Chloride storage battery.....	29, 36
test of, in storage batteries.....	56
Circuit system, "open" and "closed".....	60
Circuits, cavalry buzzer, classification of.....	107
common battery cord.....	153
desk telephone, North type.....	136
set, Sumter type.....	134
telephone.....	116
wall, North,.....	135
cordless switchboard, model 1901.....	165
cut-in telephone.....	138
field artillery telephone, model 1910.....	126
telephone, model 1910.....	124
local battery desk set, Sumter type.....	131
wall telephone, Dean,.....	130, 131
Sumter.....	127

	Page.
Circuits, magnetic	9
magneto switchboard	156, 159
ohmmeter, model 1904	271
telephone, secondary	111
signal corps bridging type	123
transmitter	111
types of	122
wall cabinet switchboard	161
Cleanliness of battery room	46
Clearing and trimming for lines	203
Closed-circuit batteries	16
cells	16
system, Morse	60
Coast artillery posts, semiannual inspection of	137
telephone systems of	146
Coefficient, temperature	302, 313
Coil, exploring	275
impedance	14
induction	14
primary	13
secondary	13
spark. (<i>See</i> Spark coil.)	
Color sequence of switchboard cable, table of	170
Combined shunt and key	261
Commercial exchanges, trunk lines to	154
standards of tensile strength of copper wire	304
values of hard-drawn copper wire	305
Common battery telephones. (<i>See</i> Telephones, common battery.)	
transmission	114
Compounds, rubber	308
Bishop	309
Habirshaw	309
Kerite	310
Okonite	309
Safety	310
Standard Underground	310
Concrete manhole	233
Condenser, capacity of	14
definition of	14
standard	262
static compensating	80
telephone	14
Conductor	10
break-in	248
liquid, resistances of	302
relative conductivity of	302
resistance of	302
specific resistance of	302
stranded copper, carrying capacity of	307
Conduit routes	241
Conduits	229, 232
Connections of polar duplex "set"	92
storage batteries	47

	Page.
Connector, buzzer, type A and B	287, 293
test	202
Continuity preserving transmitter, duplex telegraphy.....	78
Copper resistance, reduction of, to 60°	312
strands, standard.....	306
test for, in storage batteries.....	56
wire, hard-drawn, Nos. 12 and 14.....	294, 305
resistance of.....	311
table of dimensions, weight and length	308
tensile strength of.....	304
Cordless switchboards.....	161
circuits of.....	165
Core, sheathing.....	304
Covers for storage cells.....	47
Cross arms.....	184, 188, 191
connecting wire.....	295
in telegraph line.....	279
location of, by voltmeter.....	273
Current strength.....	10
Currents, induced.....	13
manner of inducing.....	13
ratio of primary to secondary.....	14
Cut-in telephone. (<i>See</i> Telephone, cut-in.)	
D.	
Dead-ending iron and steel wire.....	190, 212
“Dead man”.....	196, 198
Dean telephones. (<i>See</i> Telephones, Dean.)	
Determination of galvanometer constant, cable testing.....	267
Dielectric.....	14
specific inductive capacity of.....	14
substances.....	14
Difference, potential.....	12
measuring.....	251
Differential method of duplex telegraphy.....	75, 79
Digging holes for telegraph poles.....	186
Dimensions, standard cross arms, table of.....	184
telegraph poles, table of.....	183
Directions for setting up the pothead.....	227
and using Edison primary batteries	19, 20
Discharging storage batteries.....	40
Double cross arms.....	191
“Double-current” method of duplex telegraphy.....	87
Dry cells.....	22
allowance of, required by instruments.....	25
“Ever Ready” type of.....	25
for cavalry buzzers.....	24
field artillery telephone.....	25
internal resistance of.....	25
reserve type.....	23
size of.....	25
table of, required by instruments.....	25
size, weight, and resistance of	25
Dry plates, treatment of.....	48

	Page.
Duplex, polar.....	83, 90
balancing.....	92
set, polar, connections of.....	92
telegraphy.....	73
bridge and differential method of.....	75
continuity preserving transmitter.....	78
"double current" method.....	87
operation of differential.....	79
operation of pole changer.....	85
"Duro" portable storage batteries.....	57
Testing of.....	58
Duties of cable tester.....	265
E.	
Edison Lalande cell.....	18
Edison primary battery.....	18
Directions for setting up and using.....	19, 20
Edison storage battery.....	31
Electrical installations of the Signal Corps, inspection of.....	137
Electrical instrument case.....	258
method of using.....	263
lines of information, instruments for.....	287
resistance.....	12
Electrolyte.....	10, 45
tests for purity of.....	55
specific gravity of.....	45
Electromagnet, definition of.....	12
strength of.....	13
Electromagnetic induction.....	13
Electromagnetism.....	12
Electromotive force.....	10
Electropoison solution.....	21
Electrostatic charge, polarity of.....	13
induction.....	13
E M F.....	12, 15
End cells.....	48
English legal and Old English standard wire gauge.....	303
Equipment, field, miscellaneous.....	290
storage batteries.....	178
telegraph office.....	61
telephone switchboard.....	145, 148, 149
Erection of storage batteries, instructions for.....	31
telegraph lines.....	185
"Escapes" in telegraph lines.....	279
Evaporation, replacing of, in storage batteries.....	46
"Ever Ready" type of dry cells.....	25
Exchanges, commercial, trunks to.....	154
Exploring coil.....	275
F.	
Faults, cable.....	246, 273
in telegraph lines, location of.....	279
telephone, locating.....	140, 142
Field artillery telephone. (See Telephone, field artillery.)	
wire, twin conductor.....	295

	Page.
Field buzzer, model 1908.....	104, 287
cable.....	286
equipment, miscellaneous.....	290
induction telegraph set.....	288, 296
lines of information.....	284
magnetic.....	9
operations, wire used in.....	286
telephone, model 1910.....	123, 125, 288
transportation.....	284
wire. (<i>See</i> Wire, field.)	
Fire-control inspections.....	139
Fixtures, cross arm.....	188
Force, electromotive.....	10
lines of.....	9
Framing telegraph poles.....	187
Fuller batteries.....	20
care of.....	21
two-cell, table of.....	22
Functions of impedance coil.....	14
relay.....	62

G.

Galvanized-iron wire, No. 9 and No. 14.....	286, 294
Galvanometer.....	249, 260
D'Arsonval.....	260
constant, determination of.....	267
Generator, magneto.....	115
principle of.....	117
Gould storage battery.....	29
Gravity cell.....	16
care of.....	17
inspection of.....	17
instrumental tests of.....	17
setting up of.....	17
Ground for cable box.....	221
rods.....	291
"Grounds" in telegraph lines.....	279
Grouping of cells.....	25
Gauges, wire, table of.....	303
Guard wires.....	199, 203
Guy hooks.....	213
shims.....	213
stubs.....	184
Guying, method of.....	195, 197, 199, 201
Guys.....	194, 217

H.

Habirshaw compound.....	309
"Hand-hole".....	234
Hand receiver.....	119
reels.....	291
Handles, payout.....	291
Handling of hard-drawn copper wire.....	205
telephone cable.....	220
Hanging of telephone cable.....	220

	Page.
Hard-drawn copper wire, commercial values of.....	305
Heat coils.....	180
Holes for telegraph poles.....	186
Hooks, guy.....	213
House wire.....	295

I.

Impedance coil, functions of.....	14
Impurities in storage cells.....	46
Induced currents.....	13
E M F.....	15
Induction coil.....	14
electromagnetic.....	13
electrostatic.....	13
magnetic.....	10
Inductive capacity of dielectric condensers.....	14
Information, lines of.....	283, 284
Initial charges of storage batteries.....	35, 36
Inside twisted pair wire.....	295
Inspection, annual fire-control.....	139
electrical installations of the Signal Corps.....	137
post telephone systems.....	140
signal corps property at seacoast fortifications.....	139
semiannual, of coast artillery posts.....	137
storage batteries.....	41
Inspector's pocket kit.....	294
Installation of can top terminals.....	211
double cross arms.....	191
telephone switchboards.....	166
Instructions for erecting storage batteries.....	31
Instrument case, electrical.....	258, 263
wire.....	295
Instruments, allowance of dry cells required by.....	25
for electrical lines of information.....	287, 289
Insulated copper wires, carrying capacity.....	307
Insulating medium.....	14
Insulation test.....	267
Insulator.....	10, 185, 292
Interior wiring, carrying capacity of stranded and insulated copper wires.....	307
Intermediate switchboard.....	65
Internal resistance of batteries, measuring.....	253
dry cells.....	25
Iron, test for, in storage batteries.....	56

J.

Jar, Leyden.....	14
Jars for storage batteries, repairs to.....	47

K.

Kerite rubber compound.....	310
Key, combined shunt and.....	261
telegraph.....	61
legless.....	62
"open-circuit".....	62
telephone switchboard.....	163

L.		Page.
Lamp, pilot.....		151
supervisory signal switchboard.....		148, 151
Lance poles.....		292
Lapping for splicing telephone cable.....		220
Lead covered, paper insulated cables.....		221
Law, Ohm's.....		10
Legless key.....		62
Leyden jar.....		14
Light in battery room.....		46
Lightning arresters.....		66, 180
Mason.....		66
rods.....		184
Line construction.....		183
transposition.....		202
troubles.....		144
Lines, bracket.....		191
of force.....		9
information, classification of.....		283, 284
open-wire.....		183
telegraph. (See Telegraph lines.)		
Liquid conductors, resistance of.....		302
Location, break in conductor.....		248
cross by voltmeter.....		273
faults in cables with ohmmeter.....		273
faults in telephones.....		140
faults in telegraph lines.....		279
Logs, anchor.....		184, 196
London wire gauge.....		303
Loop tests, Murray and Varley.....		276
M.		
Magnetic circuit.....		9
field.....		9
induction.....		10
Magnetism, principles of.....		9
Magneto-generator, theory of.....		115, 117
switchboards.....		154, 156, 157, 166
North Electric, 50-drop.....		158
protectors.....		172
Main line sounders.....		64
Maintenance of telephone switchboards.....		181
Manholes.....		232
concrete.....		233
cable racking in.....		240
Mason lightning arresters.....		66
Measuring differences of potentials.....		251
resistance.....		252
Megaphone, fiber, 18-inch.....		292
Mercury, test of, in storage batteries.....		56
Messenger strand.....		213, 214
supports.....		214
Method of arranging blocks.....		216
guying.....		195, 197, 199, 201
installing double cross arms.....		191

	Page.
Method of making the pothead.....	227
placing, tying, splicing, and dead ending wires.....	188, 189, 190
terminating messenger strand.....	213
testing cable.....	242
Microtelephone.....	161
Milliammeter.....	249
Milliken repeater.....	69
Miscellaneous field equipment.....	290
tables and information.....	300
Morse telegraph.....	60
Murray loop test.....	276
N.	
Negative plate.....	10
pole.....	10
Night bell.....	151
Nitrates, test for, in storage batteries.....	56
North Electric magneto switchboard, 60-drop.....	159
telephones. (<i>See</i> Telephones, etc., North Electric.)	
Numbering poles.....	203
O.	
Obsolete types of switchboards.....	160
Office pole.....	192
Ohm.....	12
Ohm's law.....	10
Ohmmeter, locating faults in cables with.....	273
model 1904.....	263, 270, 271, 273
Okonite compound.....	309
Open-circuit batteries.....	16, 22
cells.....	16
system, Morse.....	60
telegraph key.....	62
Operation of differential duplex telegraphy.....	79
pole changer, duplex telegraphy.....	85
storage batteries.....	35, 37
telephone receiver.....	119
transmitter.....	120
Outside twisted pair wire, Nos. 12 and 14.....	294
Overcharge of storage batteries.....	38, 39
P.	
Panel, charging, storage battery.....	178
Paper-core cables.....	209
Payout handles.....	291
Permanent lines of information.....	283
Pikes, wire.....	292
Pilot cell.....	37, 38, 39, 41
lamp.....	151
Pintle type wire wagon.....	284
Placing wires, method of.....	188
Plates, dry, treatment of.....	48
for cells.....	10
size of, for storage batteries.....	31
Pocket relay.....	64

	Page.
Polar duplex. (<i>See</i> Duplex, polar.)	
Polarity of electrostatic charges.....	14
Polarized bell.....	121
relay.....	87, 89
Pole braces.....	197, 200
changer, duplex telegraphy, operation of.....	85
Western Union.....	93
lance.....	292
negative.....	10
office.....	192
positive.....	10
Poles.....	183
framing.....	187
numbering of.....	203
setting.....	193
telegraph, delivery of.....	187
digging holes for.....	186
length of.....	183
number required.....	184
preparation of.....	184
size of holes, table of.....	186
table of dimensions.....	183
Pony relay.....	63
Post telephone systems, allowance of telephones for.....	145, 147
inspection of.....	140
Potential difference.....	12, 251
Pothead, method of making.....	227
terminal.....	192
wire.....	295
Power equipment of telephone switchboards.....	145
“Primary”.....	13
Primary battery.....	16
circuit of buzzer.....	105, 110
coil.....	13
Principle of magnetism.....	9
magneto generator.....	117
transformer.....	14
Protection of telephone cable.....	221
Protective equipment of switchboards.....	145, 148, 172, 174, 180
Pulling cable.....	237
Putting storage batteries out of commission.....	49
R.	
Racks, type of storage battery.....	34
Ratings of storage batteries, table of.....	30
Receiver, operation of telephone.....	119
Record of conduit routes.....	241
Records of cable splices.....	222
storage batteries.....	40, 56
Reduction of copper resistance to 60°.....	312
Reels, breast.....	290
hand.....	291
Reference table for tester.....	308
Relative conductivity and resistance of conductors.....	302

	Page.
Relay box.....	63
functions of.....	62
pocket.....	64
polarized.....	87, 89, 93
pony.....	63
Reliability of telegraphy in comparison to telephony.....	289
Repairs to jars or tanks for storage batteries.....	47
Repeaters, Milliken.....	69
telegraph.....	69
Weiny-Phillips.....	71
Reports, storage batteries.....	56
Reserve type dry cell.....	23
Resistance.....	10
electrical.....	12
internal, of dry cells.....	25, 253
liquid conductors.....	302
measuring.....	252, 253
of pure copper wire.....	311
relative, of conductors.....	302
specific.....	300, 302
unit of.....	300
Ringer, telephone.....	121
River crossings.....	203
Rods, anchor.....	196, 198
ground.....	291
lightning.....	184
Roebing, standard of wire gauge.....	303
Routes, conduit, record of.....	241
Rubber compounds.....	308
S.	
Safety rubber compound.....	310
Seacoast fortifications, inspection of signal corps property at.....	139
“Secondary”.....	13
Secondary battery. (See Storage battery.)	
circuit buzzer.....	110
of telephone.....	106, 111
coil.....	13
Sediment in storage batteries.....	44
Self-induction.....	101
Semiannual inspection of coast artillery posts.....	137
Semipermanent lines of information.....	283
Service testing battery.....	262
Setting of telegraph poles.....	193
Sheathing core.....	304
Shims, guy.....	213
Shunt and key, combined.....	261
Signal Corps, inspection of electrical installations of.....	137
property at seacoast fortifications, inspection of.....	139
Size of dry cells.....	25
storage-battery plates.....	31
switchboard cable.....	170
wire used in field operations.....	286
Solenoid, definition of.....	12

	Page.
Sounder.....	64
adjustment of.....	96
"main-line".....	64
Spark coil.....	80
Specific gravity of electrolyte.....	45
storage battery, after charge.....	39, 40
inductive capacity of dielectric condensers.....	14
resistance.....	300, 302
Speed in telegraphy as compared to telephony.....	290
Splicing cables.....	220, 221, 222, 226, 228
wires.....	190, 214, 296
Standard condenser.....	262
copper strands.....	306
sizes of signal corps switchboard cable.....	170
Underground Company's rubber compound.....	311
Static compensating condensers.....	80
Stearns duplex.....	77
Storage batteries.....	16, 27
care of.....	41
central energy.....	177
charged in parallel.....	39
charging panel.....	178
rate.....	31, 38
chemical action of.....	27
Chloride.....	29
cleanliness of battery room.....	46
connections.....	47
covers.....	47
discharging.....	40
rate.....	40
"Duro" portable.....	57
Edison.....	31
equipment of.....	178
general instructions.....	46, 50
Gould.....	29
impurities.....	46
initial charge.....	35
inspection of.....	41
instructions for erecting.....	31
light, effect of, on.....	46
limit of discharge.....	40
methods of manufacture.....	28
operation and maintenance of.....	35, 37, 41, 43, 46, 50
pilot cell.....	37
putting out of commission.....	49
readings.....	40, 50
records of.....	40, 56
repairs.....	47
replacing evaporation.....	46
reports of.....	56
sediment in.....	44
separate charging.....	43
size of.....	178
plates.....	31

	Page.
Storage batteries, summary of important points.....	50
table of ratings.....	30
telautograph.....	53
telegraph.....	50
telephone.....	52
tests for chloride, iron, copper, mercury, and nitrates.....	56
tests for purity of electrolyte in.....	55
types of.....	31
racks for.....	34
ventilation and temperature of battery room.....	46
voltage at end of charge.....	39
voltage and specific gravity after charge.....	39
Willard.....	29
Stranded copper conductors, carrying capacity of.....	307
Strands, copper, standard.....	306
Strategical lines of information.....	284
Strength, current.....	10
tensile, of copper wire.....	304
Stringing wire.....	206
Stubs, guy.....	184
wire gauge.....	303
Sumter type common battery desk set.....	133
wall telephone.....	132
local battery desk set.....	131
wall telephone.....	127
Supports, messenger.....	214
Switchboards, cable, standard sizes of signal corps.....	170
table of color sequence.....	170
central energy visual supervisory.....	148, 151
cordless.....	161, 165
correcting troubles in.....	181
intermediate or "way station".....	65
lamp supervisory signal.....	148
magneto.....	154, 156, 157, 166
North Electric, 50-drop.....	158
obsolete types of.....	160
protective equipment for.....	149, 172, 174, 180
telegraph.....	65
telephone.....	145, 147, 166
equipment for.....	145, 148
installation of.....	166, 172
keys for.....	163
maintenance of.....	181
terminal office.....	67
testing of.....	181
wall-cabinet.....	160
circuit of.....	161

T.

Table, carrying capacity of copper wires for inside wiring.....	307
color sequence of switchboard cable.....	170
dimensions of standard cross arms.....	184
telegraph poles.....	183
weight and length of pure copper wire.....	308

	Page.
Table, dry cells required by instruments.....	25
miscellaneous.....	300
properties of telephone cable.....	219
various sizes of telegraph wire.....	209
ratings of storage batteries.....	30
reduction of copper resistance to 60°.....	312
reference, for tester.....	308
resistance of pure copper wire at 75°.....	311
size, internal resistance and weight of dry cells.....	25
of holes for telegraph poles.....	186
Standard Underground Company's rubber "D".....	311
temperature coefficients.....	313
wire gauges.....	303
Tactical lines of information.....	284
Telautograph batteries.....	53
Telegraph apparatus, adjustment of.....	94
wet-weather effects on.....	94
batteries.....	50
field induction set.....	288
key.....	61
lines, clearing and trimming for.....	203
"crosses," "escapes," and "grounds".....	279
erection of.....	185
location of faults.....	279
wet-weather effects on.....	94
wire for.....	185
Morse circuit system, "open" and "closed".....	60
office equipment.....	61
poles. (<i>See</i> Poles, telegraph.)	
repeaters. (<i>See</i> Repeaters, telegraph.)	
set, field induction.....	296
switchboard.....	65
wire.....	209
Telegraphy, accuracy and reliability of.....	289
adjusting for maximum strength.....	96
adjustment of sounders.....	96
duplex. (<i>See</i> Duplex telegraphy.)	
feeling for a distant station.....	95
instruments for use in field.....	289
speed in.....	290
Telephone battery troubles.....	143
bridging type, circuits of.....	123
cable, attaching to messenger.....	221
handling of, hanging and lapping for splicing.....	220
protection of.....	221
splicing lead-covered, paper insulated.....	221
table of properties of.....	219
circuits.....	116, 122
common battery.....	132
desk set, Sumter type.....	133, 134
North Electric type.....	133, 135
transmission.....	114
wall, Sumter type.....	132

	Page.
Telephone cut-in.....	135, 138
Dean, local battery, wall.....	130, 131
field, model 1910.....	123, 125, 288
field artillery.....	25
dry cell for.....	25
model 1910.....	126
lines. (<i>See</i> Lines, telephone.)	
local battery desk set, Sumter type.....	131
transmission.....	113
wall, Sumter type.....	127
receiver, operation of.....	119
ringer.....	121
switchboard.....	145, 147, 148, 166, 172, 181
equipment.....	145, 148
keys.....	163
systems at coast artillery posts.....	145
theory of.....	112
transmitter, circuit of.....	106
operation of.....	120
troubles.....	140, 143
Telephones, allowance of, to post telephone systems.....	145, 147
elimination of trouble in.....	140
locating faults in.....	140
secondary circuit of.....	106
summary of faults.....	142
storage batteries for.....	52
types of.....	122
Temperature of battery room.....	46
coefficient.....	302, 313
Tensile strength of copper wire.....	304
Terminal cabinet.....	149
can-top.....	209, 211, 212
office switchboard and battery arrangements.....	67
pothead.....	192
Test connector.....	202
for chlorine, iron, copper, mercury, and nitrates in batteries.....	56
purity of electrolyte in storage batteries.....	55
of cable.....	242
Tester, cable.....	265
reference tables for.....	308
Testing "Duro" batteries.....	58
voltammeter for.....	272
Theory of the buzzer.....	101
polar duplex.....	90
telephone.....	112
Thimbles.....	214
Three-way or Y cable splices.....	226
Tools for construction of lines.....	206, 207
Transformer.....	14
Transmission, common battery.....	114
local battery.....	113
Transmitter circuit of telephone.....	106, 111
continuity-preserving, duplex telegraphy.....	78
operation of.....	120

	Page.
Transportation, field.....	284
Transposition.....	198, 202
Treatment of dry plates.....	48
Trenching of underground cables.....	229
Trimming and clearing for telegraph lines.....	203
Trouble in telephones, elimination of.....	140, 143
telephone lines.....	144
Trunk lines to commercial exchanges.....	154
Tying of wires on telegraph poles.....	189
Type A and B buzzer connectors.....	287, 293
V cells.....	18
Types, closed circuit cells.....	16
storage batteries.....	31
battery racks.....	34
telephones.....	122
telephone circuits.....	122
U.	
Units of resistance.....	300
V.	
Varley loop test.....	276
Ventilation of battery room.....	46
Voltaic cell.....	10
Voltage, of storage battery at end of charge.....	39
after charge.....	39
testing, of battery.....	251
Voltammeter for testing batteries.....	272
Voltmeter.....	249, 251
location of "cross" by means of.....	273
W.	
Wagon, wire, pintle type.....	284
Wall-cabinet switchboard, circuit of.....	160, 161
Wall telephone. (<i>See Telephone, wall.</i>)	
Washburn & Moens, standard of wire gauge.....	303
Way-station switchboards.....	65
Weight of wire used in field operations.....	286
Weiny-Phillips repeater.....	71
Western Union pole changer.....	93
Wet-weather effects on telegraph lines and apparatus.....	94
Wheatstone bridge.....	254
Willard storage batteries.....	29
specific gravity of electrolyte in.....	45
Wire, buzzer.....	286, 295
cart.....	284
copper. (<i>See Copper wire.</i>)	
field.....	286, 294, 296
galvanized, No. 9 and No. 14.....	286, 294
gauge.....	303
guard.....	199, 203
hard-drawn copper, commercial values of.....	305
handling of.....	205, 294, 305
messenger strand, method of terminating.....	213

	Page.
Wire, method of placing.....	188
tying, splicing, and dead-ending.....	188, 189, 190, 214, 296
pike.....	292
stringing.....	206
telegraph.....	185
table of properties of.....	209
types used by the Signal Corps.....	294
used in field operations.....	286, 294, 295
wagon, pintle type.....	284
Y.	
Y or 3-way cable splices.....	226

O













M210784

U G 70
U G
115

THE UNIVERSITY OF CALIFORNIA LIBRARY

